

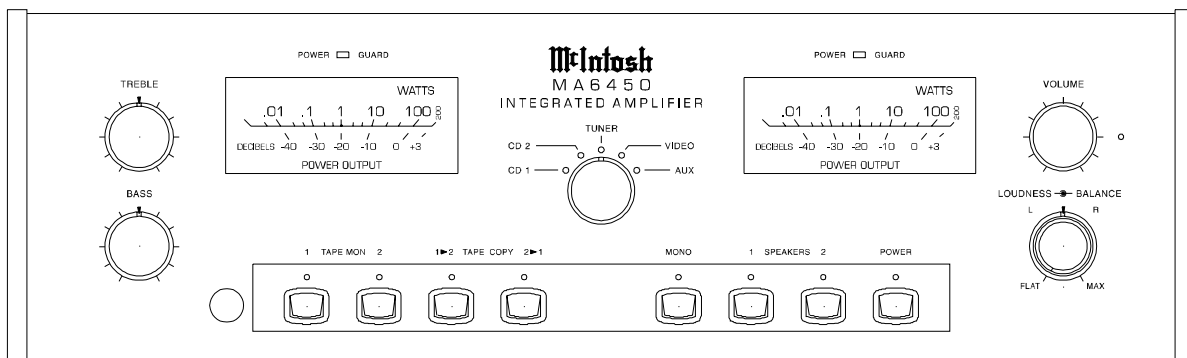

## MA6450 Integrated Amplifier



MA6450



## Thank You, Please Take A Moment, Customer Service and Table of Contents

### Thank You

For your decision to own this McIntosh MA6450 Integrated Amplifier ranks you at the very top among discriminating music listeners. You now have "The Best." The McIntosh dedication to "Quality," is assurance that you will receive many years of musical enjoyment from this unit.

Please take a short time to read the information in this manual. We want you to be as familiar as possible with all the features and functions of your new McIntosh MA6450. This will ensure that you receive all the performance benefits this equipment can offer you, and that it will become a highly valued part of your home entertainment system.

### Please Take A Moment

The serial number, purchase date and McIntosh dealer name are important to you for possible insurance claim or future service. The serial number is located on the rear panel of the equipment. The spaces below have been provided for you to record that information:

**Serial Number:** \_\_\_\_\_

**Purchase Date:** \_\_\_\_\_

**Dealer Name:** \_\_\_\_\_

### Customer Service

If at any time you have questions about your McIntosh MA6450 Intergrated Amplifier, contact your McIntosh dealer. Your dealer is familiar with your McIntosh equipment as well as other brands that may be included in your system and is best qualified to help you.

If it is determined that your MA6450 is in need of repair, you can return it to your dealer or you can return it to McIntosh Laboratory. Contact the McIntosh Repair Department for assistance at,

McIntosh Laboratory, Inc.  
2 Chambers Street  
Binghamton, New York 13903  
Phone: 607-723-3512  
FAX: 607-724-0549

### Table of Contents

Thank You .....	2
Please Take a Moment .....	2
Customer Service .....	2
Table of Contents .....	2
Safety Instructions .....	3
Introduction .....	4
Performance Features .....	4
Installation .....	5
Rear Panel Connections .....	6
How to Connect .....	7
How to Connect for Video Switching .....	8
Front Panel Controls, Displays, Push-Buttons, and Switches .....	9
How to Operate .....	10
HR-033 Push-Buttons .....	12
How to Operate by Remote Control .....	13
Specifications .....	14
Packing Instruction .....	15

#### NOTES:

1. Connecting Cables are available from the McIntosh Parts Department:  
**Data and Power Control Cable Part No. 170-202**  
Six foot, shielded 2 conductor, with 1/8 inch stereo mini phone plugs on each end.
2. For additional connection information, refer to the owner's manual(s) for any component(s) connected to the MA6450 Amplifier.
3. There is a built-in turn on delay which will mute the speaker outputs for approximately two seconds when the amplifier is turned on.
4. If the rear panel processor switch is set to the in position, and a signal processor is not connected, no sound will be heard through the system. When a signal processor is connected to the MA6450 processor jacks, and the processor switch is set to the in position, the processor must be on and operating, or in bypass mode, for a sound to be heard through the system.
5. It is very important that loudspeaker cables of adequate size be used in your music system, to ensure that there will be no power loss or heating. Cable size is specified in Gauge numbers or AWG, (American Wire Gauge). The smaller the Gauge number, the larger the wire size:  
If your loudspeaker cables are 25 feet (7.62m) or less, use at least 18 Gauge (AWG) wire size or larger.  
If your loudspeaker cables are 50 feet (38.1m) or less, use at least 16 Gauge (AWG) wire size or larger.  
If your loudspeaker cables are 100 feet (76.2m) or less, use at least 14 Gauge (AWG) wire size or larger.

## IMPORTANT SAFETY INSTRUCTIONS!

PLEASE READ THEM BEFORE OPERATING THIS EQUIPMENT.



**WARNING SHOCK HAZARD - DO NOT OPEN.**



**AVIS RISQUE DE CHOC - NE PAS OUVRIR.**



**CAUTION**  
RISK OF ELECTRIC SHOCK  
DO NOT OPEN

**NO USER-SERVICEABLE PARTS INSIDE. REFER SERVICING TO QUALIFIED PERSONNEL**



**ATTENTION**  
DANGER D'ELECTROCUTION  
NE PAS OUVRIR

### General:

1. Read all the safety and operating instructions, contained in this owner's manual, before operating this equipment.
2. Retain this owner's manual for future reference about safety and operating instructions.
3. Adhere to all warnings and operating instructions.
4. Follow all operating and use instructions.
5. **Warning: To reduce risk of fire or electrical shock, do not expose this equipment to rain or moisture. This unit is capable of producing high sound pressure levels. Continued exposure to high sound pressure levels can cause permanent hearing impairment or loss. User caution is advised and ear protection is recommended when playing at high volumes.**
6. **Caution: to prevent electrical shock do not use this (polarized) plug with an extension cord, receptacle or other outlet unless the blades can be fully inserted to prevent blade exposure.**  
**Attention: pour prevenir les chocs electriques pas utiliser cette fiche polarisee avec un prolongateur, une prise de courant ou un autre sortie de courant, sauf si les lames peuvent etre inserees afond ans en laisser aucune partie a decouvert.**
7. For added protection for this product during a lightning storm, or when it is left unattended and unused for long periods of time, unplug it from the wall outlet and disconnect the antenna or cable system. This will prevent damage to the product due to lightning or power line surges.

8. Do not use attachments not recommended in this owner's manual as they may cause hazards.

### Installation:

9. Locate the equipment for proper ventilation. For example, the equipment should not be placed on a bed, sofa, rug, or similar surface that may block ventilation openings; or, placed in a built-in installation, such as a bookcase or cabinet, that may impede the flow of air through the ventilation openings.
10. Locate the equipment away from heat sources such as radiators, heat registers, stoves, or other appliance (including amplifiers) that produce heat.
11. Mount the equipment in a wall or cabinet only as described in this owner's manual
12. Do not use this equipment near water; for example, near a bathtub, washbowl, kitchen sink, laundry tub, in a wet basement or near a swimming pool, etc.
13. Do not place this product on an unstable cart, stand, tripod, bracket, or table. The equipment may fall, causing serious injury to a person, and serious damage to the product.

### Connection:

14. Connect this equipment only to the type of AC power source as marked on the unit.
15. Route AC power cords so that they are not likely to be walked on or pinched by items placed upon or against them, paying particular attention to cords at plugs, convenience receptacles, and the point where they exit from the instrument.
16. Do not defeat the inherent design features of the polarized plug. Non-polarized line cord adapters will defeat the safety provided by the polarized AC plug. If the plug should fail to fit, contact your electrician to replace your obsolete outlet. Do not defeat the safety purpose of the grounding-type plug.
17. Do not overload wall outlets, extension cords or integral convenience receptacles as this can result in a risk of fire or electric shock.

### Care of Equipment:

18. Clean the instrument by dusting with a dry cloth. Unplug this equipment from the wall outlet and clean the panel with a cloth moistened with a window cleaner. Do not use liquid cleaners or aerosol cleaners.
19. Do not permit objects of any kind to be pushed and/or fall into the equipment through enclosure openings.



Never spill liquids into the equipment through enclosure openings.

20. Unplug the power cord from the AC power outlet when left unused for a long period of time.

#### **Repair of Equipment:**

21. Unplug this equipment from the wall outlet and refer servicing to a qualified service personnel under the following conditions:
  - A. The AC power cord or the plug has been damaged.
  - B. Objects have fallen, or liquid has been spilled into the equipment.
  - C. The equipment has been exposed to rain or water.
  - D. The equipment does not operate normally by following the operating instructions contained within this owner's manual. Adjust only those controls that are covered by the operating instructions, as an improper adjustment of other controls may result in damage and will often require extensive work by a qualified technician to restore the product to its normal operation.
  - E. The equipment has been dropped or damaged in any way.
  - F. The equipment exhibits a distinct change in performance - this indicates a need for service.
22. Do not attempt to service beyond that described in the operating instructions. All other service should be referred to qualified service personnel.
23. When replacement parts are required, be sure the service technician has used replacement parts specified by McIntosh or have the same characteristics as the original part. Unauthorized substitutions may result in fire, electric shock, or other hazards.
24. Upon completion of any service or repairs to this product, ask the service technician to perform safety checks to determine that the product is in proper operating condition.

#### **Introduction**

The remote controlled MA6450 is a sophisticated, yet easy to operate Integrated Amplifier that will provide the superior fidelity music reproduction that is traditional from McIntosh. It includes a wide range of convenient operating functions to enhance your listening enjoyment. The classic McIntosh MA6450 will perfectly complement a pair of McIntosh Loudspeakers for a stereo system of incomparable performance and style.

#### **Performance Features**

- **100 Watt per Channel Integrated Amplifier**

The MA6450 combines 100 watt per channel power amplifier with a sophisticated control center in one compact unit.

- **Multiple Inputs**

Seven high level inputs provide for all popular program sources.

- **Tone Control Bypass**

At the flat settings the Bass and Treble control circuit elements are removed from the Listen signal path.

- **Active Loudness Circuitry**

A continuously variable active Loudness control allows any degree of loudness compensation. All Loudness circuit elements are removed from the signal path in the flat setting.

- **Electronic Input Switching**

Digital Logic integrated circuits drive Electromagnetic switches on all inputs and operating functions for reliable, noiseless, distortion free switching

- **Illuminated Peak Responding Output Meters**

Output meters respond to 95% of full scale reading with a single cycle of a 2KHz tone burst to indicate output power with high accuracy.

- **Power Guard with Sentry Monitor**

Patented McIntosh Power Guard circuit that prevents the amplifier from being overdriven into clipping with its harsh distorted sound that can also damage your valuable loudspeakers. Sentry Monitor power output stage protection circuits ensure the MA6450 will have a long and trouble free operating life.

- **Speaker Switching**

Front panel Speakers push-buttons control two pairs of speakers.

- **Special Power Supply**

Fully regulated power supply with a shielded power transformer ensures stable noise free operation.

**Installation**

The MA6450 can be placed upright on a table or shelf, standing on its four feet. It also can be custom installed in a piece of furniture or cabinet of your choice. The required panel cutout, ventilation cutout and unit dimensions are shown.

Always provide adequate ventilation for your MA6450. Cool operation ensures the longest possible operating life for any electronic instrument. Do not install the MA6450 directly above a heat generating component such as a high powered amplifier. If all the components are installed in a single cabinet, a quiet running ventilation fan can be a defi-

nite asset in maintaining all the system components at the coolest possible operating temperature.

A custom cabinet installation should provide the following minimum spacing dimensions for cool operation. Allow at least 2 inches (5.1cm) above the top and 1 inch (2.54 cm) on each side of the amplifier, so that airflow is not obstructed. 21 inches (53.3cm) depth behind the mounting panel, which includes clearance for connectors. Allow 1-1/8 inches (2.9cm) in front of the mounting panel for knob clearance. Be sure to cut out a ventilation hole in the mounting shelf according to the dimensions in the drawing.

Front View of the MA6450 custom installed

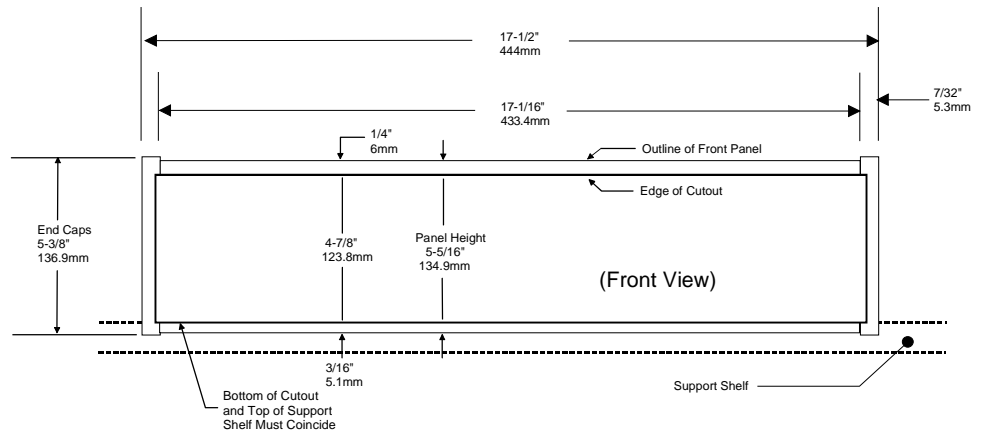

Side View of the MA6450 custom installed

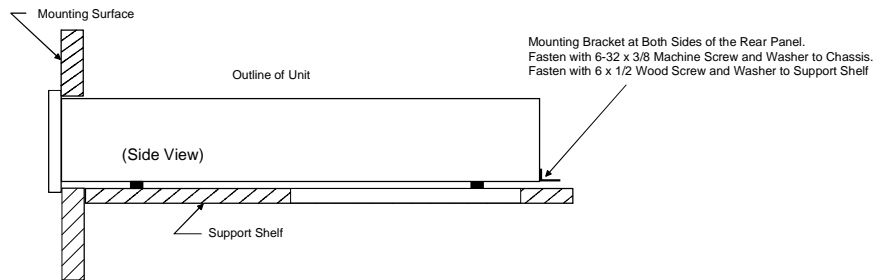

Bottom View of the MA6450 custom installed

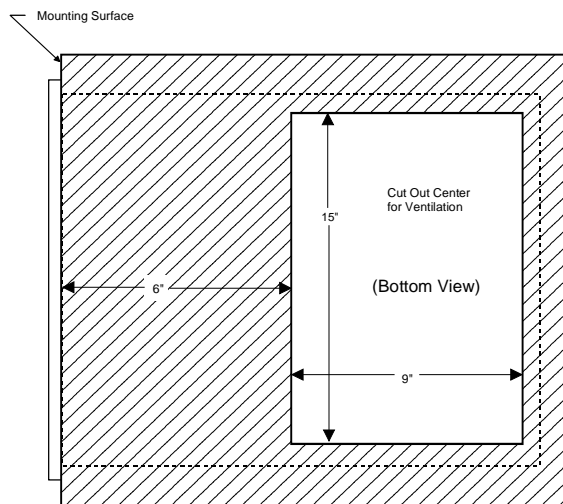



MA6450 Rear Panel Connections

SUM Data port allows connection of a McIntosh Remote Control Translator

MAIN OUTPUTS send signals to power amplifier inputs, POWER AMP IN jacks accept signals from an external preamplifier or signal source, EXT-INT PWR AMP INPUT switch disconnects the power amplifier from the built-in preamplifier

PROCESSOR FROM and TO jacks along with PROCESSOR IN-OUT switch for an external signal processor

TAPE 1, and TAPE 2 inputs are for tape recorders

DATA PORTS send signals to compatible source components to allow you to remotely control them

RECORD TAPE 1 and 2 OUTPUTS supply record signals for tape recorders

High Level Inputs accept signals from the output of a TUNER, CD 1&2, and AUX

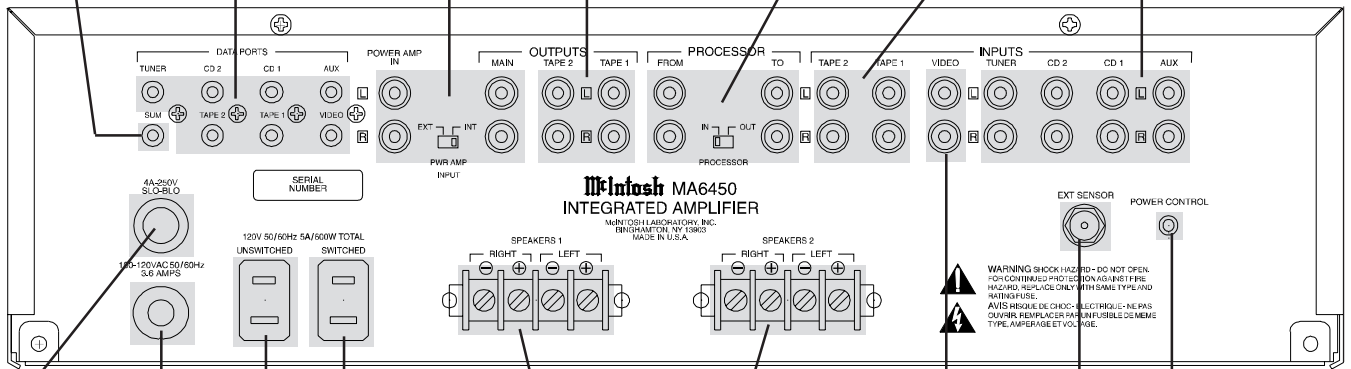

Fuse holder, refer to information on the back panel to determine the correct fuse size and rating.

SWITCHED outlet turns on and off with the MA6450 main power switch

VIDEO, inputs for audio signals from a LD, VCR, TV or the optional MVS-3 A/V Selector

POWER CONTROL Output sends a turn-on signal to a McIntosh Component

Connect the MA6450 power cord to a live AC outlet. Refer to information on the back panel to determine the correct voltage.

UNSWITCHED outlet stays on all the time

SPEAKERS 1 and SPEAKERS 2 allow two pairs of speakers to be connected

The EXT (external) Sensor for a McIntosh IR sensor

## How to Connect the MA6450

1. Connect the MA6450 power cord to a live AC outlet.
2. Connect cables from a pair of speakers to the SPEAKER 1 Outputs.

*Note: After connecting the loudspeakers, install the supplied protective covers (located in an accessory package in the shipping carton) over the loudspeaker terminals.*

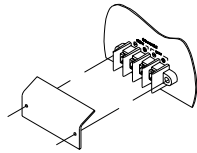

3. Connect a cable from the TAPE 1 OUTPUTS to the Record Inputs of a tape recorder and the TAPE 1 INPUTS to a tape recorder Outputs.
4. Connect cables from a McIntosh CD Player to the CD1 INPUTS. Connect a McIntosh tuner to the TUNER INPUTS.
5. Connect a cable from the POWER CONTROL jack to

6. Connect a cable(s) from the DATA PORTS to the components that are to be controlled by the MA6450.
7. Connect a Coax cable from the EXT SENSOR to a McIntosh wall sensor or WK-2 Keypad in a second room.

*NOTE: If a Signal Processor is Used, connect cables from the Signal Processor Outputs to the PROCESSOR FROM jacks and the Signal Processor Inputs to the PROCESSOR TO jacks. Set the MA6450 PROCESSOR switch to IN. The processor must be on or in bypass mode for a signal to be heard.*

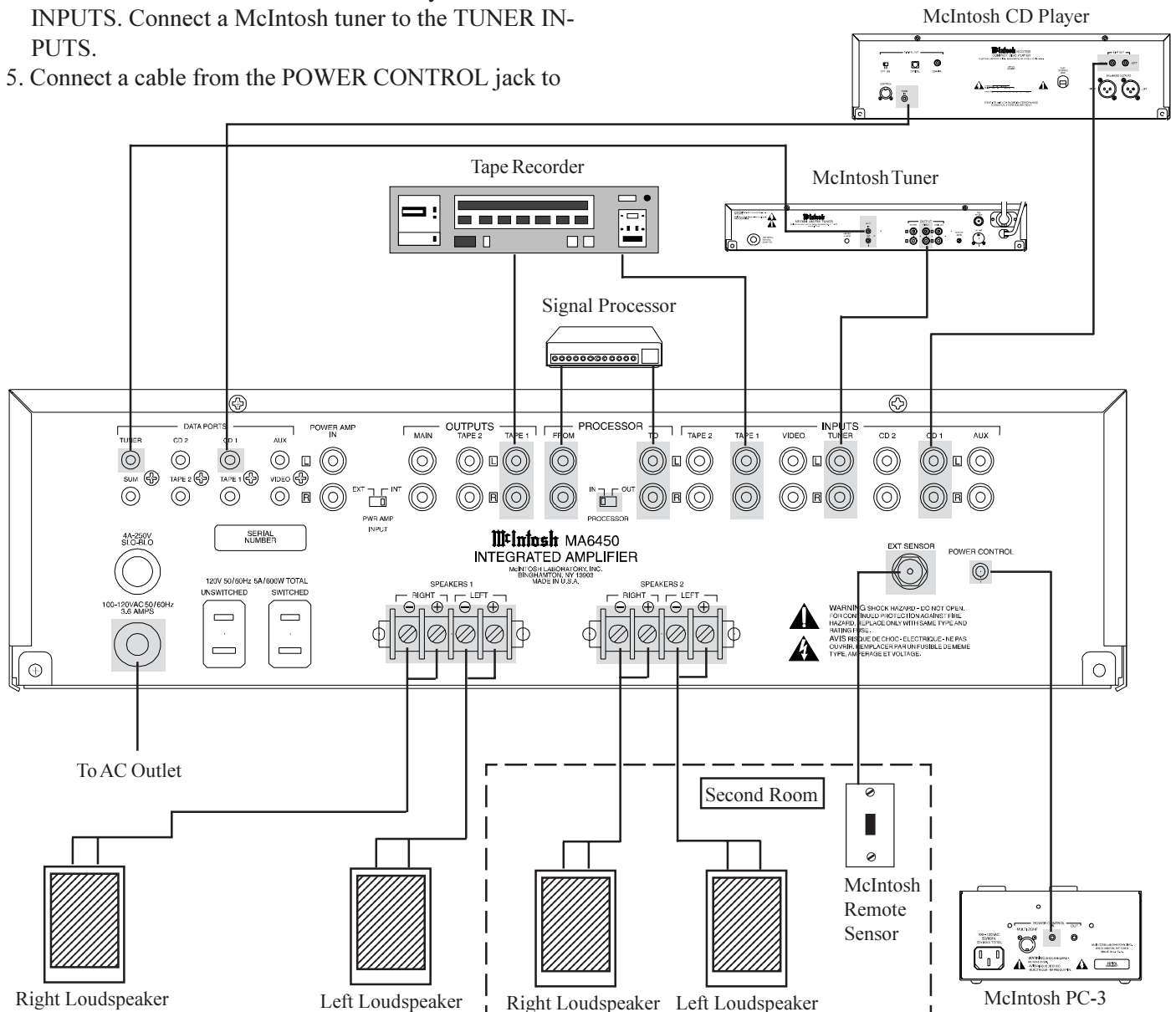



## How to Connect the MA6450 for Video Switching

### How to Connect the MA6450 for Video Switching

1. Connect the MVS-3 power cord to the Switched outlet.
2. Connect a Data cable from the MA6450 VIDEO DATA PORT to the MVS-3 DATA IN jack.
3. Connect the MVS-3 CONTROL CENTER OUTPUTS to the MA6450 VIDEO Inputs.
4. Connect the MVS-3 VIDEO MONITOR OUTPUT to a TV or Monitor.
5. Connect a McIntosh LD Player audio outputs to the MVS-3 LV AUDIO INPUTS, the video output to the MVS-3 LV VIDEO INPUT and the DATA OUT to the MVS-3 LV DATA PORT.
6. Connect other video source components to the appropriate audio and video inputs on the MVS-3.

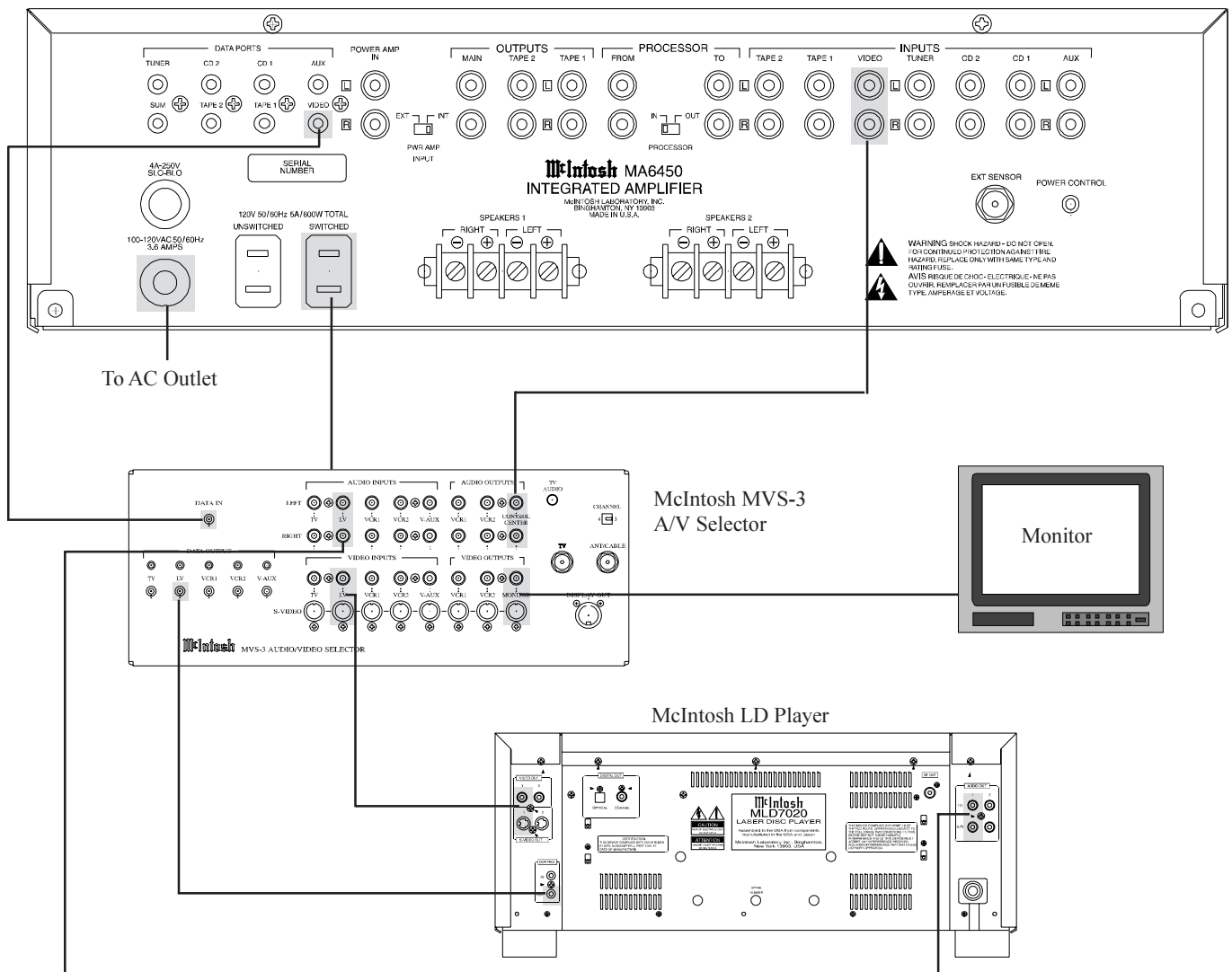



# MA6450 Front Panel Controls, Display, Push-Buttons and Switches

## MA6450 Front Panel Controls, Display, Push-Buttons and Switches

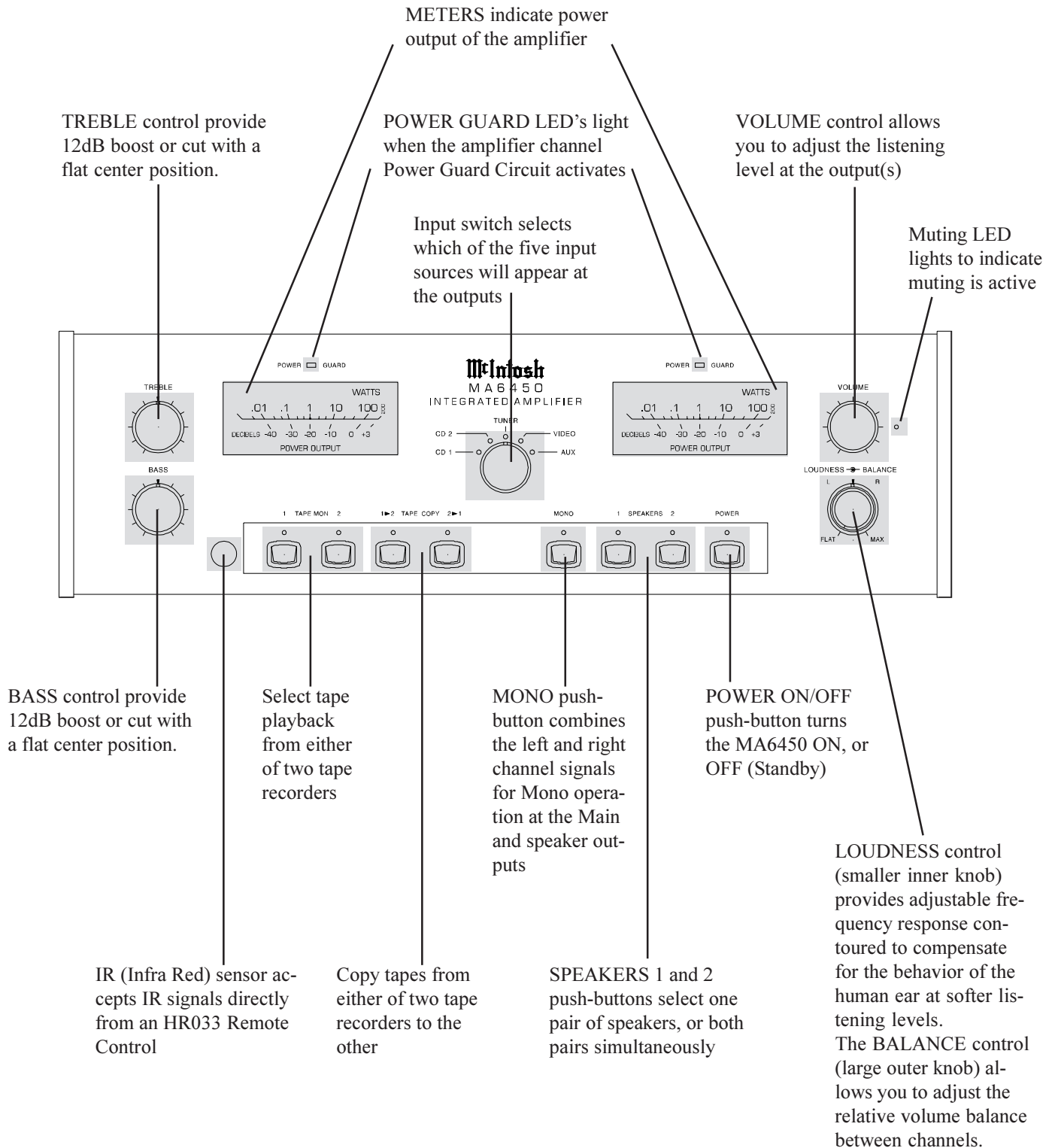



## How to Operate the MA6450

### Power On

Press the POWER push-button to turn the MA6450 on and off.

Note: The red LED above the push-button stays on whenever the MA6450 power cord is connected to a live outlet. You may also turn the MA6450 on and off using the HR033 Remote Control.

*NOTE: You may also turn on the MA6450 using the HR033 Remote Control.*

### Source Selection

Select the desired listening source with the Input Switch.

### Tape Mon 1 and 2

Press a TAPE MON (Tape Monitor) push-button to playback a previously recorded tape or monitor a tape playback during the recording process.

*NOTE: The TAPE MON push-buttons are electronically interlocked so only one recorder playback can be selected at a time. If a 3 head tape recorder is being used, you can monitor the tape playback during the recording process by pressing the appropriate TAPE MON push-button.*

### Volume Control

Adjust the VOLUME control for the desired listening level.

### Balance Control

Adjust the BALANCE control as needed to achieve approximately equal listening volume levels in each loudspeaker. Turn the BALANCE to the Left to emphasize the left channel by reducing the level of the right channel. Turn the BALANCE to the right to emphasize the right channel by reducing the level of the left channel.

### Bass and Treble Controls

Adjust the BASS and TREBLE controls to suit your listening preferences. The bass or treble intensity can be increased with clockwise rotation and decreased with counterclockwise rota-

tion. All tone control circuit elements are removed from the signal path when the controls are in the center or flat position.

### Loudness Control

After first setting the desired listening volume, rotate the LOUDNESS control clockwise to increase the intensity of the bass according to your listening preference. When the LOUDNESS control is in the fully counter clockwise or flat position, all loudness circuit elements are removed from the signal path.

### Mono

Press the MONO push-button to combine left and right stereo signals to mono at MAIN OUTPUT and SPEAKERS 1 and 2.

### Mute

Press MUTE on the Remote Control to mute audio in the MAIN OUTPUT and SPEAKERS 1 and 2. Press again, select another Input or press a Tape Mon push-button to unmute.

*NOTE: When the MA6450 is in Mute, the Speakers push-buttons, Mono push-button and Tape Copy push-buttons are inoperative.*

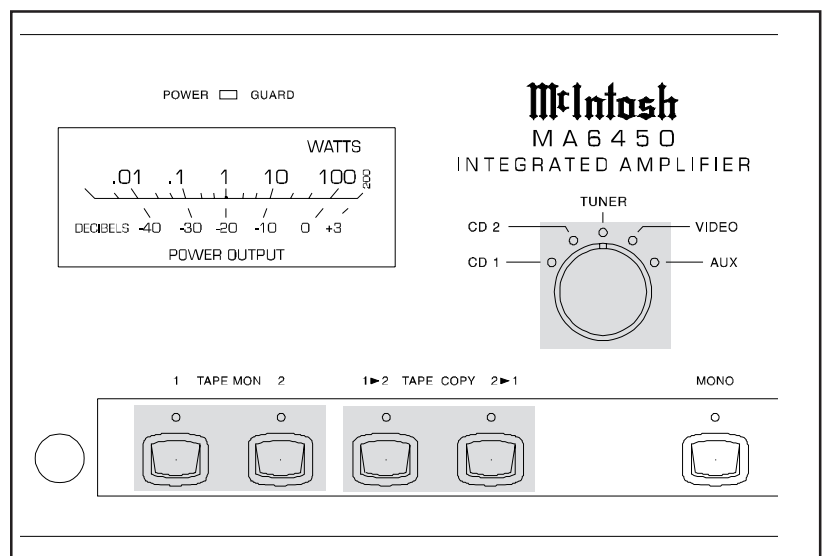

Figure 1

### Speakers 1 and 2

Press SPEAKERS 1 or 2 push-buttons to switch the two pairs of speakers on or off. You can press either push-button individually, or both together.

### Reset of Microprocessors

In the event that the controls of the MA6450 stop functioning, remove the MA6450 power cord from the AC outlet. Wait approximately two minutes and then replace the power cord in the outlet. This will reset the MA6450 microprocessors and the amplifier should be functioning normally.

*NOTE: The above condition is usually caused by either interruptions in AC power and/or major changes in voltage.*

### How to Make a Tape Recording

Select the desired input source to be recorded with the Input selector switch. This signal will appear at both Tape Outputs 1 and 2 and allow either or both machines to record the selected signal. The selected signal source will also be available at the main outputs and both pairs of speaker outputs. To play back the recording, press a TAPE MON push-button. Refer to Figure 1.

*NOTE: If a 3 head tape recorder is being used, you can monitor the tape playback during the recording process by pressing the appropriate TAPE MON push-button.*

### How To Make an Audio Tape Copy

Press the TAPE COPY 1-2 push-button to copy tapes from Tape Recorder 1 in playback mode to tape recorder 2 in record mode. Press TAPE COPY 2-1 to copy tapes from Tape Recorder 2 in playback mode to Tape Recorder 1 in record mode. During the tape copy process, you can listen to tape playback by pressing a TAPE MON push-button. Refer to Figure 1.

*NOTE: You can also listen to any other signal source while copying a tape.*

### How to Read the Power Output Meters

The MA6450 Power Output Meter scales are based on using 4 ohm loudspeakers. The meters are peak responding and indicate the power output of each channel with high accuracy when the amplifier is reproducing music. The power outputs for the meter scale indications between the numerical markings (high lighted in gray) are shown below.

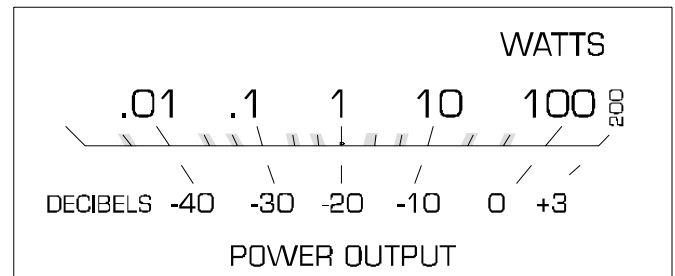

Meter Reading	Actual Power Output
100	100 Watts
-	40 Watts
-	20 Watts
10	10 Watts
-	4 Watts
-	2 Watts
1	1 Watts
-	0.4 Watts
-	0.2 Watts
0.1	0.1 Watts
-	0.04 Watts
-	0.02 Watts
0.01	0.01 Watts
-	0.004 Watts



HR033 Push-Buttons

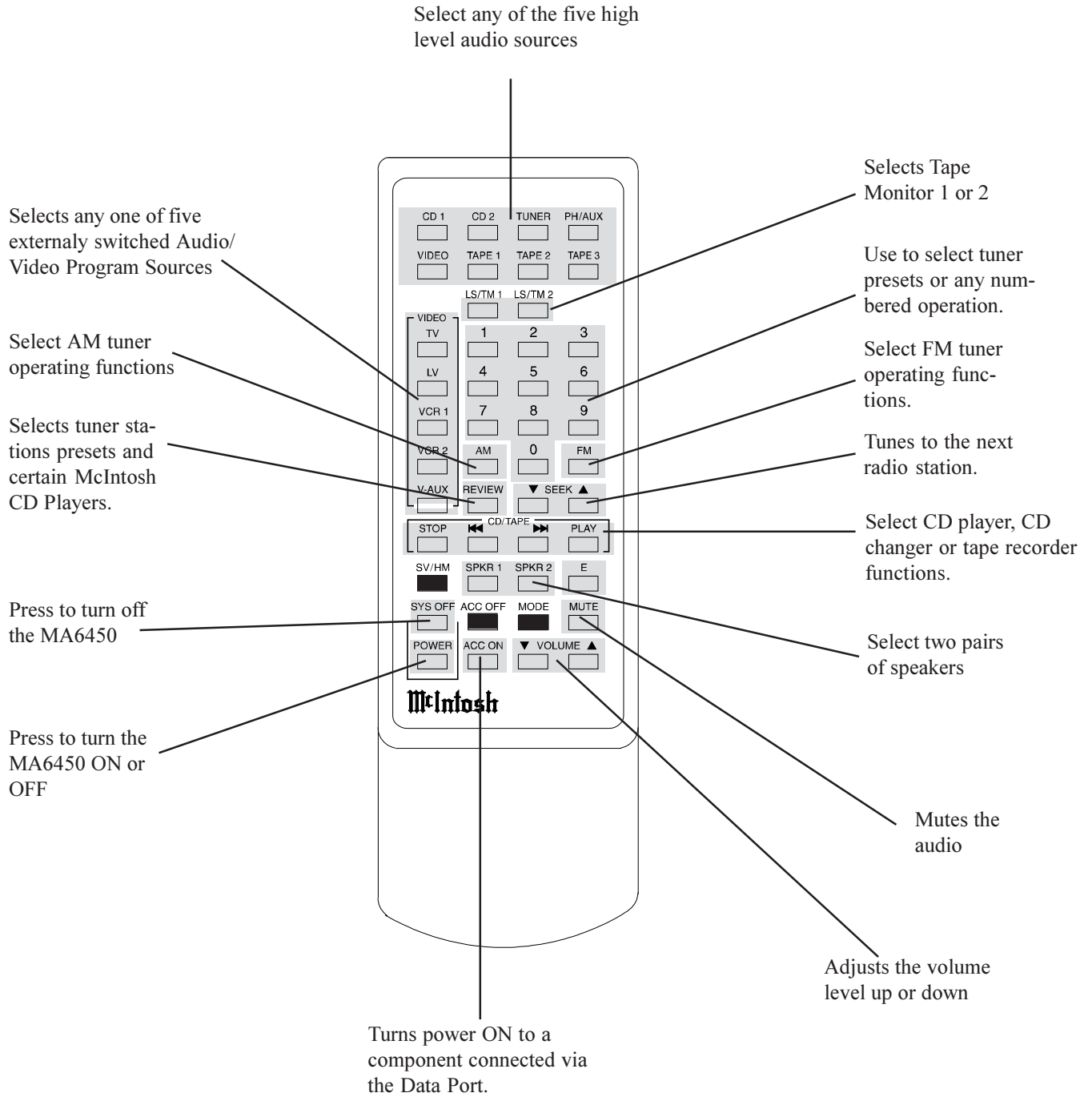

*Note: The HR033 Remote Control push-buttons that are shown in black only work with other McIntosh Products.*

### How to Operate HR033

#### Mute

Press MUTE to mute the audio signals at the MAIN OUTPUTS and SPEAKERS. The MUTE LED, to the right of the volume control will turn on to indicate that Mute is active. Press MUTE a second time to unmute audio.

#### Mono

Press the MONO push-button to combine left and right stereo signals to mono at the MAIN OUTPUT and SPEAKERS.

#### Audio

Press any of the five Audio push-buttons to select a program source.

#### Video/Audio Selection

When the optional McIntosh MVS-3 Audio/Video Selector is added, first press VIDEO, and then the desired push-button to select any of the five A/V sources connected to the MVS-3.

#### CD/Tape

Use these push-buttons to operate a CD player, CD changer or tape recorder, when the component is connected to the MA6450 with a McIntosh RCT Translator.

#### Numbered Push-buttons

Press push-buttons 0 through 9 to access tuner station presets or CD tracks/discs.

#### Tuner Push-buttons

Use with a McIntosh tuner. Select AM or FM broadcast band. Press and release SEEK Up or Down to move from station to station. Press and hold a SEEK push-button to move continuously from station to station. Press REVIEW to start the automatic brief audition of each of the presets stored in the tuner memory. Press REVIEW a second time to stop on a station preset and exit the Review process.

#### Volume

Press the Up or Down VOLUME push-button to raise or lower the listening volume level.

*NOTE: The Tape Record Outputs are not affected.*

#### Speaker Selection

Press SPKR 1 or SPKR 2 push-buttons to switch two pairs of speakers on and off separately or together.

#### Acc On

Press ACC ON to turn power ON of a McIntosh LV or DVD Disc Player.

*NOTE: When other brands of components are connected with a McIntosh Remote Control Translator (RCT), refer to the RCT Owner's Manual for further information on alternate HR033 push-button functions.*



### Specifications

#### Power Output Per Channel

100 watts into 4 ohm loads minimum sine wave continuous average power output per channel both channels operating.

#### Output Load Impedance

4 ohms

#### Rated Power Band

20Hz to 20,000Hz

#### Dynamic Headroom

2.4dB

#### Frequency Response

+0, -0.5dB from 20Hz to 20,000Hz

#### Total Harmonic Distortion

0.005% maximum at any power level from 250 milliwatts to rated power per channel from 20Hz to 20,000Hz, all channels operating.

#### Intermodulation Distortion

0.005% maximum if instantaneous peak output per channel does not exceed twice the rated output with all channels operating for any combination of frequencies from 20Hz to 20,000Hz.

#### Signal To Noise Ratio

110dB below rated output, Power Amplifier  
100dB below rated output, Preampifier

#### Sensitivity

250mV for 2.5V rated output, Preampifier inputs  
2.5V for rated output, Power Amplifier

#### Preampifier Maximum Voltage Output

8V from 20Hz to 20,000Hz

#### Preampifier Maximum Input Signal

10V

#### Damping Factor

Greater than 40

#### Power Requirements

100 Volts, 50/60Hz at 3.6 amps  
110 Volts, 50/60Hz at 3.6 amps  
120 Volts, 50/60Hz at 3.6 amps  
220 Volts, 50/60Hz at 1.8 amps  
230 Volts, 50/60Hz at 1.8 amps  
240 Volts, 50/60Hz at 1.8 amps

*NOTE: Refer to the rear panel of the MA6450 for the correct voltage*

#### Dimensions

Front Panel: 17 1/2 inches (44.5cm) wide, 5-3/8 inches (13.7cm) high. Depth behind front mounting panel is 18 1/8 inches (46cm) including clearance for connectors. Panel clearance required in front of mounting panel is 1-1/8 inches (2.9cm).

#### Weight

41 pounds (18.6Kg) net, 60 pounds (27.2Kg) in shipping carton

## Packing Instructions

In the event it is necessary to repack the equipment for shipment, the equipment must be packed exactly as shown below. It is very important that the four plastic feet are attached to the bottom of the equipment. This will ensure the proper equipment location on the bottom pad. Failure to do this will result in shipping damage.

Use the original shipping carton and interior parts only if they are all in good serviceable condition. If a shipping carton or any of the interior part(s) are needed, please call or write Customer Service Department of McIntosh Laboratory. Please see the Part List for the correct part numbers.

Quantity	Part Number	Description
1	033838	Shipping carton only
2	033837	End Cap (Foam Pad)
1	033836	Inside carton only
1	033725	Top Pad
1	033698	Bottom pad
3	017218	Plastic foot (spacer)
1	033699	Wood skid
3	101169	#10 x 2-1/4" Wood screw
3	104033	#10 x 1-3/4" Wood screw
4	017218	Plastic foot
4	100159	#10-32 x 3/4" Machine screw
4	104080	#10 x 7/16" Flat washer
1	048432	Shipping carton complete with all the above parts

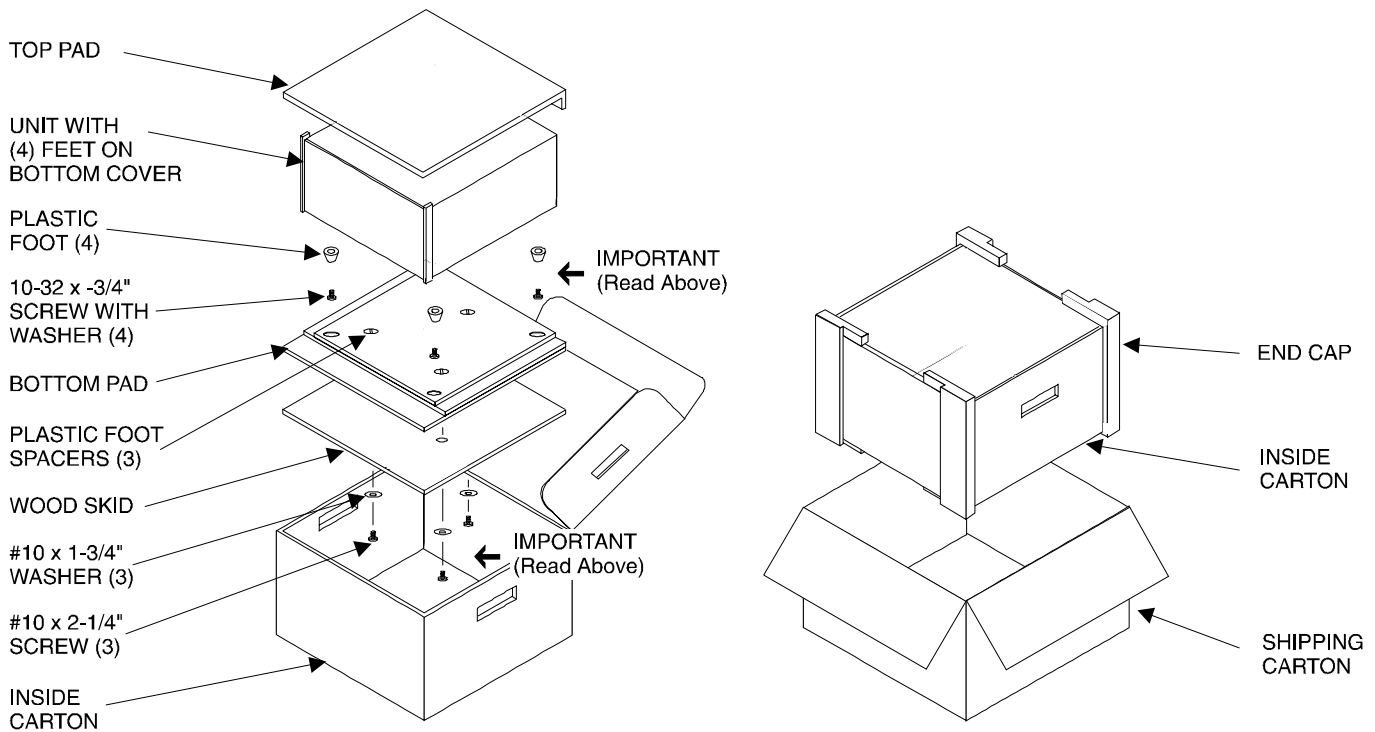

**McIntosh<sup>®</sup>**

McIntosh Laboratory, Inc.  
2 Chambers Street  
Binghamton, NY 13903

McIntosh Part No. 040561