



Power Amplifier



MC1.2KW Owner's Manual

The lightning flash with arrowhead, within an equilateral triangle, is intended to alert the user to the presence of uninsulated “dangerous voltage” within the product’s enclosure that may be of sufficient magnitude to constitute a risk of electric shock to persons.



AVIS RISQUE DE CHOC ELECTRIQUE - NE PAS OUVRIR.

The exclamation point within an equilateral triangle is intended to alert the user to the presence of important operating and maintenance (servicing) instructions in the literature accompanying the appliance.

WARNING - TO REDUCE RISK OF FIRE OR ELECTRICAL SHOCK, DO NOT EXPOSE THIS EQUIPMENT TO RAIN OR MOISTURE.

NO USER-SERVICEABLE PARTS INSIDE. REFER SERVICING TO QUALIFIED PERSONNEL.

To prevent the risk of electric shock, do not remove cover or back. No user-serviceable parts inside.

IMPORTANT SAFETY INSTRUCTIONS!

PLEASE READ THEM BEFORE OPERATING THIS EQUIPMENT.

1. Read these instructions.
2. Keep these instructions.
3. Heed all warnings.
4. Follow all instructions.
5. Do not use this apparatus near water.
6. Clean only with a dry cloth.
7. Do not block any ventilation openings. Install in accordance with the manufacturer’s instructions.
8. Do not install near any heat sources such as radiators, heat registers, stoves, or other apparatus (including amplifiers) that produce heat.
9. Do not defeat the safety purpose of the polarized or grounding-type plug. A polarized plug has two blades with one wider than the other. A grounding type plug has two blades and a third grounding prong. The wide blade or the third prong are provided for your safety. If the provided plug does not fit into your outlet, consult an electrician for replacement of the obsolete outlet.
10. Protect the power cord from being walked on or pinched particularly at plugs, convenience receptacles, and the point where they exit from the apparatus.
11. Only use attachments/accessories specified by the manufacturer.
12. Use only with the cart, stand, tripod, bracket, or table specified by the manufacturer, or sold with the apparatus. When a cart is used, use caution when moving the cart/apparatus combination to avoid injury from tip-over. 
13. Unplug this apparatus during lightning storms or when unused for long periods of time.
14. Refer all servicing to qualified service personnel. Servicing is required when the apparatus has been damaged in any way, such as power-supply cord or plug is damaged, liquid has been spilled or objects have fallen into the apparatus, the apparatus has been exposed to rain or moisture, does not operate normally, or has been dropped.
15. Do not expose this equipment to dripping or splashing and ensure that no objects filled with liquids, such as vases, are placed on the equipment.
16. To completely disconnect this equipment from the a.c. mains, disconnect the power supply cord plug from the a.c. receptacle.
17. The mains plug of the power supply cord shall remain readily operable.
18. Do not expose batteries to excessive heat such as sunshine, fire or the like.

Thank You

Your decision to own this McIntosh MC1.2KW Power Amplifier ranks you at the very top among discriminating music listeners. You now have “The Best.” The McIntosh dedication to “Quality,” is assurance that you will receive many years of musical enjoyment from this unit. Please take a short time to read the information in this manual. We want you to be as familiar as possible with all the features and functions of your new McIntosh.

Please Take A Moment

The serial number, purchase date and McIntosh Dealer name are important to you for possible insurance claim or future service. The spaces below have been provided for you to record that information:

Serial Number: _____

Purchase Date: _____

Dealer Name: _____

Technical Assistance

If at any time you have questions about your McIntosh product, contact your McIntosh Dealer who is familiar with your McIntosh equipment and any other brands that may be part of your system. If you or your Dealer wish additional help concerning a suspected problem, you can receive technical assistance for all McIntosh products at:

McIntosh Laboratory, Inc.
2 Chambers Street
Binghamton, New York 13903
Phone: 607-723-1545
Fax: 607-724-0549

Customer Service

If it is determined that your McIntosh product is in need of repair, you can return it to your Dealer. You can also return it to the McIntosh Laboratory Service Department. For assistance on factory repair return procedure, contact the McIntosh Service Department at:

McIntosh Laboratory, Inc.
2 Chambers Street
Binghamton, New York 13903
Phone: 607-723-3515
Fax: 607-723-1917

Copyright 2007 © by McIntosh Laboratory, Inc.

Table of Contents

Safety Instructions	2
Thank You and Please Take a Moment.....	3
Technical Assistance and Customer Service	3
Table of Contents	3
General Information	3
Connector Information	4
Introduction.....	4
Performance Features	4
Dimensions	5
Installation	6
Rear Panel Connections and Switch	7
How to Connect	8-9
How to Connect for Bi-Amp.....	10-11
Front Panel Displays and Controls.....	12
How to Operate	13
Technical Description	14-17
Specifications.....	18
Packing Instruction.....	19

General Information

Caution: The MCI.2KW Amplifier weight is 147 pounds (66.7 kilograms). It requires two or more persons to safely handle when moving the amplifier.

1. The following Connecting Cable is available from the McIntosh Parts Department:
Power Control Cable Part No. 170-202
Six foot, 2 conductor shielded, with two 1/8 inch stereo mini phone plugs.
2. For additional connection information, refer to the owner's manual(s) for any component(s) connected to the MCI.2KW.
3. The MCI.2KW mutes the speaker output for approximately two seconds when first turned on.
4. It is very important that loudspeaker cables of adequate size be used, so that there will be no power loss. The size is specified in Gauge Numbers or AWG, (American Wire Gauge). The smaller the Gauge number, the larger the wire size:
If your loudspeaker cables are 50 feet (38.1m) or less, use at least 14 Gauge.
If your loudspeaker cables are 100 feet (76.2m) or less, use at least 12 Gauge.
5. In the event the MCI.2KW over heats, due to improper ventilation and/or high ambient temperature, the protection circuits will activate. The Front Panel Power Guard LED will continuously indicate ON and the audio will be muted. When the MCI.2KW has returned to a safe operating temperature, normal operation will resume.
6. The MCI.2KW incorporates the very latest in Fully Double Balanced Circuitry. As a result, the Loudspeaker ⊖ Negative Connections are above chassis ground. Do not combine any connections together, ground them or connect with another MCI.2KW.

Connector and Cable Information

XLR Connectors

Below is the Pin configuration for the XLR Balanced Input Connectors on the MC1.2KW. Refer to the diagram for connection:

- PIN 1: Shield/Ground
- PIN 2: + Output
- PIN 3: - Output

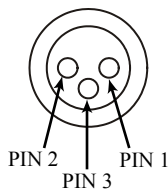

Power Control Connector

The MC1.2KW's Power Control Inputs receive On/Off signals of +5 volts. An additional connection is for controlling the illumination of the MC1.2KW Power Output Meters. The 1/8 inch stereo mini phone plug connects to a McIntosh A/V Control Center Power Control Output.

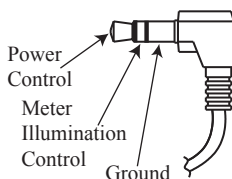

Note: The Power Control Connecting Cable is available from the McIntosh Parts Department:

Data and Power Control Cable Part No. 170-202

Six foot, shielded 2 conductor, with 1/8 inch stereo mini phone plugs on each end.

Introduction

Now you can take advantage of traditional McIntosh standards of excellence in the MC1.2KW Power Amplifier. The 1,200 watt high current output will drive any high quality loudspeaker system to its ultimate performance. The MC1.2KW reproduction is sonically transparent and absolutely accurate. The McIntosh Sound is "The Sound of the Music Itself."

Performance Features

• Power Output

The MC1.2KW is a Power Amplifier with a capability of 1,200 watts into 2, 4 or 8 ohm speakers with less than 0.005% distortion.

• Full Balanced Quad-Differential Circuitry

The MC1.2KW is fully balanced from inputs to outputs. It consists of two matched power amplifiers operating in push-pull with their outputs combined in a McIntosh Autoformer. The double balanced configuration cancels virtually all distortion.

• Balanced and Unbalanced Inputs

Balanced connections guard against induced noise and allow long cable runs without compromising sound quality.

• Power Guard

The patented McIntosh Power Guard circuit prevents the amplifier from being over driven into clipping, with its harsh distorted sound that can also damage your valuable loudspeakers.

• Sentry Monitor and Thermal Protection

McIntosh Sentry Monitor power output stage protection circuits ensure the MC1.2KW will have a long and trouble free operating life. Built-in Thermal Protection Circuits guard against overheating.

• Patented Autoformer

McIntosh designed and manufactured Output Autoformers provide an ideal match between the amplifier output stages and speaker loads of 2, 4 and 8 ohms. The Autoformers also provide perfect DC protection for your valuable loudspeakers.

• Special Power Supply

A regulated Power Supply, a very large Toroidal Wound Power Transformer and very large capacitors ensures stable noise free operation even though the power line varies.

• Illuminated Power Meter

The Illuminated Power Output Watt Meter on the MC1.2KW is peak responding, and indicates the true power output of the amplifier. The Peak Watt Hold Mode allows the meter to temporarily stay at the highest power output and then slowly decay. The Front Panel Meter Illumination may be switched Off at any time.

• Fiber Optic Solid State Front Panel Illumination

The even Illumination of the Front Panel is accomplished by the combination of custom designed Fiber Optic Light Diffusers and extra long life Light Emitting Diodes (LEDs).

• Glass Front Panel and Super Mirror Chassis Finish

The famous McIntosh Illuminated Glass Front Panel and the Stainless Steel Chassis with Super Mirror Finish ensures the pristine beauty of the MC1.2KW will be retained for many years.

Dimensions

The following dimensions can assist in determining the best location for your MC1.2KW. There is additional information on the next page pertaining to installing the MC1.2KW into cabinets.

Front View of the MC1.2KW

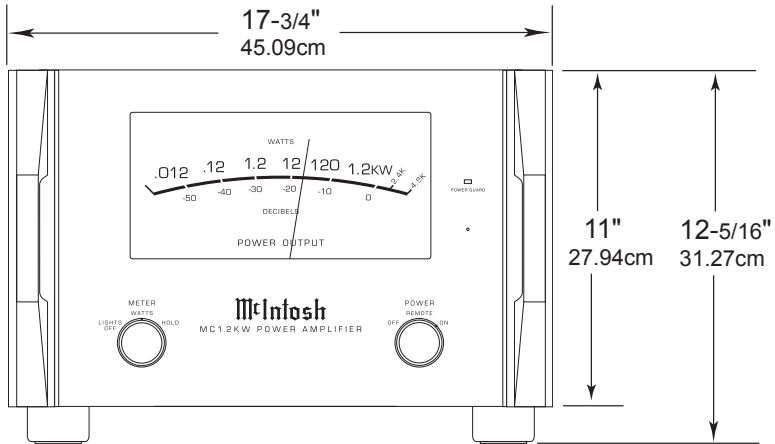

Rear View of the MC1.2KW

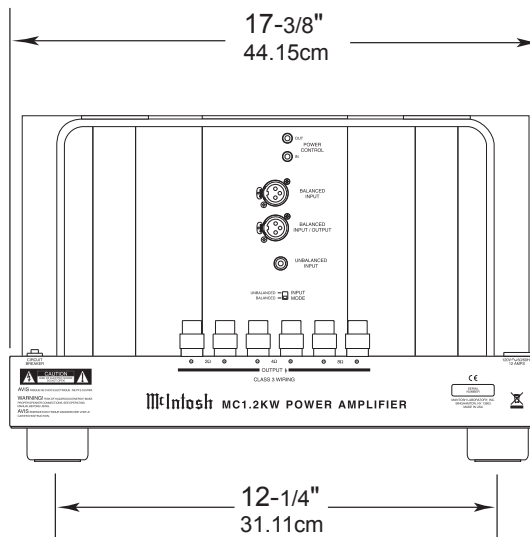

Side View of the MC1.2KW

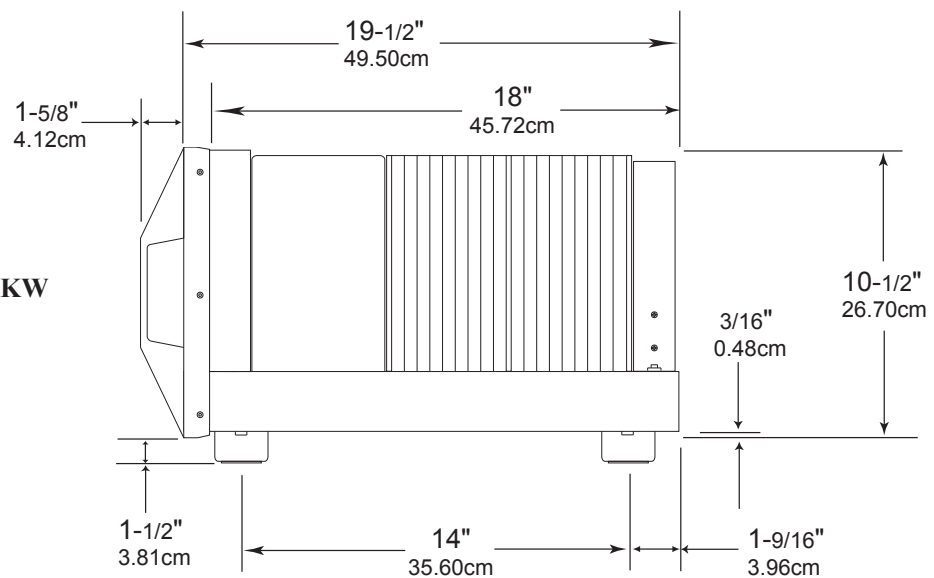

Installation

The MC1.2KW can be placed upright on a table or shelf, standing on its four feet. It also can be custom installed in a piece of furniture or cabinet of your choice. The four feet may be removed from the bottom of the MC1.2KW when it is custom installed as outlined below. The four feet together with the mounting screws should be retained

for possible future use if the MC1.2KW is removed from the custom installation and used free standing. The required panel cutout, ventilation cutout and unit dimensions are shown. Always provide adequate ventilation for your MC1.2KW. Cool operation ensures the longest possible operating life for any electronic instrument. Do not install the MC1.2KW directly above a heat generating component such as a high powered amplifier. If all the components are installed in a single cabinet, a quiet running ventilation fan can be a definite asset in maintaining all the system components at the coolest possible operating temperature.

A custom cabinet installation should provide the following minimum spacing dimensions for cool operation. Allow at least 6 inches (15.24cm) above the top, 2 inches (5.08cm) below the bottom and 1 inch (2.54cm) on each side of the Power Amplifier, so that airflow is not obstructed. Allow 19-1/2 inches (49.53cm) depth behind the front panel. Allow 1-5/8 inch (4.12cm) in front of the mounting panel¹ for clearance. Be sure to cut

out a ventilation hole in the mounting shelf according to the dimensions in the drawing.

¹ When the MC1.2KW is installed together with other McIntosh Components, check clearances on all components before proceeding.

MC1.2KW Front Panel Custom Cabinet Cutout

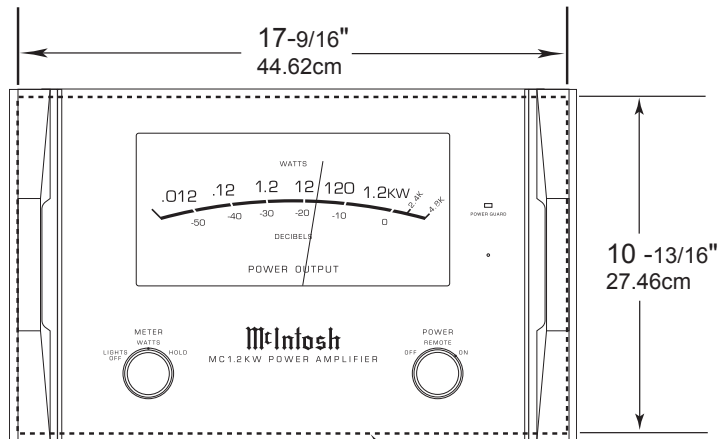

MC1.2KW Side View in Custom Cabinet

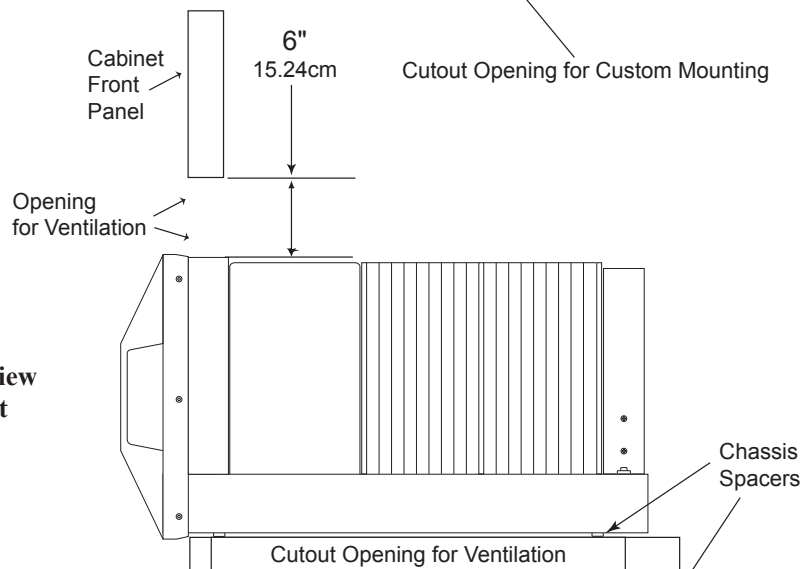

MC1.2KW Bottom View in Custom Cabinet

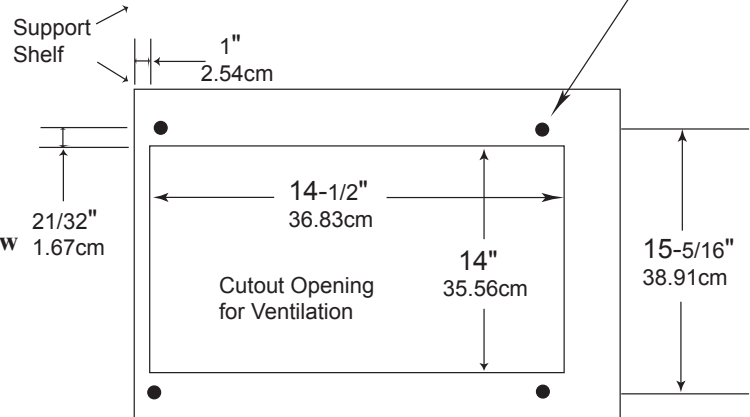

Rear Panel Connections and Switch

Circuit Breaker, press to reset if the amplifier will not power up

BALANCED INPUT¹ / OUTPUT for an audio cable from a Preamplifier output or to connect an audio cable onto the next Power Amplifier input

BALANCED INPUT for an audio cable from a Preamplifier or A/V Control Center audio output

Connect the MC1.2KW power cord to a live AC outlet. Refer to the rear panel to determine the correct voltage

INPUT MODE switch selects between balanced or unbalanced input

POWER CONTROL IN receives turn On/Off signal from a McIntosh component and the POWER CONTROL OUT sends a turn On/Off signal to the next McIntosh Component

UNBALANCED INPUT for an audio cable from a Preamplifier or A/V Control Center audio output

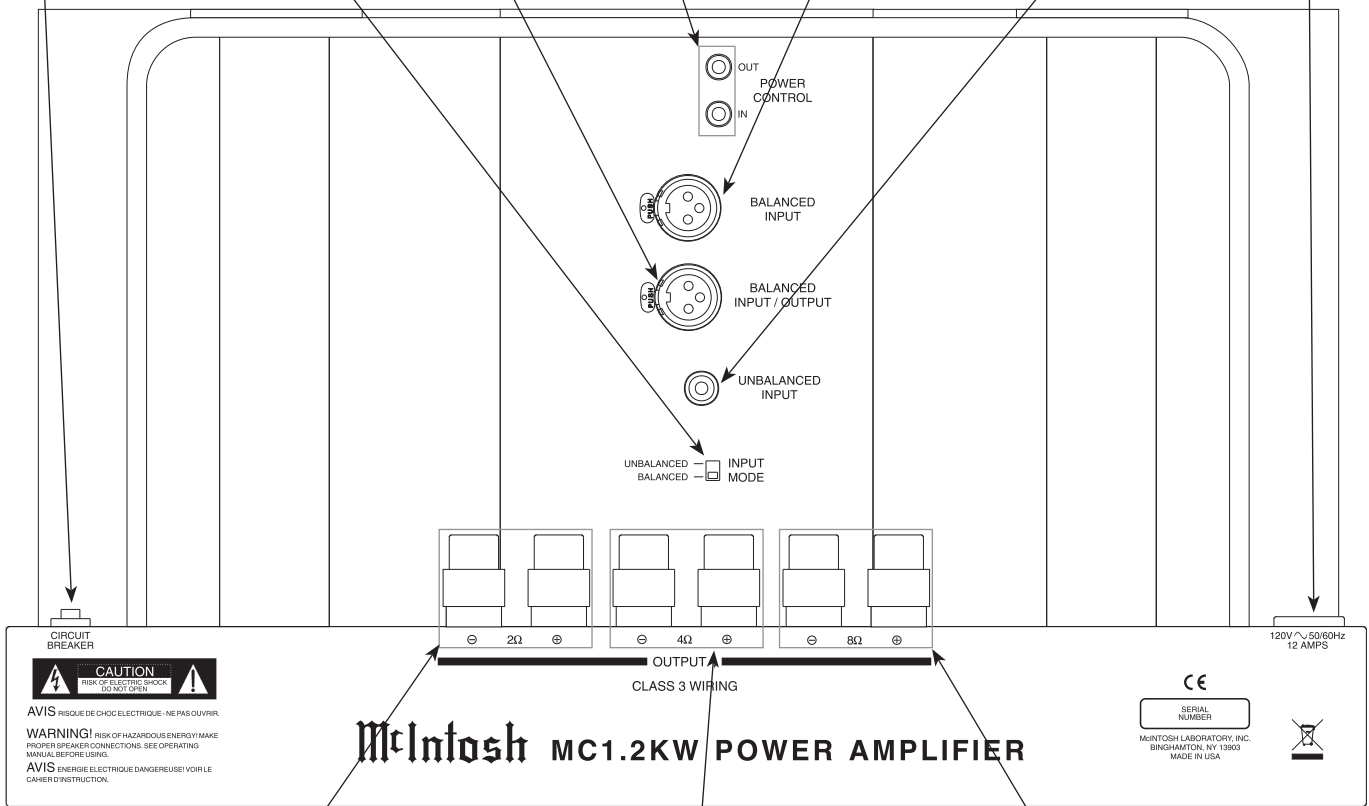

OUTPUT Connections for 2 ohm Loudspeaker

OUTPUT Connections for 4 ohm Loudspeaker

OUTPUT Connections for 8 ohm Loudspeaker

Caution: The Loudspeaker ⊖ Negative Connections are above chassis ground. Do not combine any connections together, ground them or connect with another MC1.2KW.

¹ This Balanced connector may be used as an Input ONLY when connected to a McIntosh C1000 Preamplifier. For all other connections use only as an Output.



How to Connect

Caution: The supplied AC Power Cord should not be connected to the Rear Panel of the MC1.2KW Amplifier until after the Loudspeaker Connections have been made and the supplied protective Terminal Connections Cover has been installed. Failure to observe this could result in Electric Shock.

1. For Remote Power Control, connect a power control cable from the Control Center or Preamplifier Power Control Out to the MC1.2KW POWER CONTROL IN.
2. Connect a cable from the Balanced Output of a McIntosh Preamplifier or Control Center to the MC1.2KW BALANCED INPUT. Place the INPUT MODE Switch in the BALANCED Position.

Note: An optional hookup is to use an unbalanced cable and place the INPUT MODE Switch in the UNBALANCED Position.

3. Prepare the Loudspeaker Hookup Cable for attachment to the MC1.2KW Power Amplifier:

Bare wire cable ends:

Carefully remove sufficient insulation from the cable ends, refer to figures 1, 2 & 3. If the cable is stranded, carefully twist the strands together as tightly as possible.

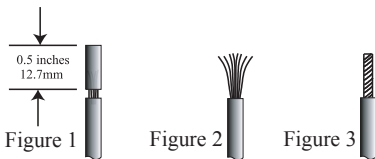

Notes: 1. If desired, the twisted ends can be tinned with solder to keep the strands together.

2. Banana plugs are for use in the United States and Canada only. In the United States, when using the 8 ohm loudspeaker terminals, it is mandatory to use banana plugs inserted into the top hole of the loudspeaker terminals in order to comply with safety standard requirements.

Connection Method for use inside the United States and Canada only:

Attach the previously prepared bare wire cable ends into the banana plugs and secure the connections. Insert the banana plug only into the hole at the top of the terminal. Refer to figures A and B.

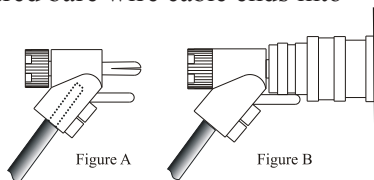

Connection Method for use outside the United States and Canada:

Attach the previously prepared bare wire cable ends into the spade lug connectors and secure the connections. Insert the spade lug connector or prepared section of the cable end into the terminal side access hole, and tighten the terminal cap until the cable is firmly clamped into the

terminals so the lugs cannot slip out. Refer to figures 4, 5 & 6.

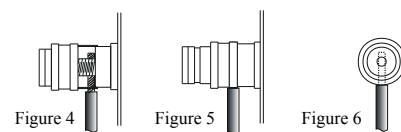

4. Connect the loudspeaker hookup cable to the output terminals that match the impedance of your loudspeaker, being careful to observe the correct polarities. Output impedance connections of 2 ohms, 4 ohms and 8 ohms are provided. If the impedance of your loudspeaker is in-between the available connections, use the nearest lower impedance connection.

WARNING: Loudspeaker terminals are hazardous live and present a risk of electric shock. For additional instruction on making Loudspeaker Connections contact your McIntosh Dealer or McIntosh Technical Support.

5. Attach the supplied Terminal Connections Cover with the four Phillips Head Mounting Screws (10-32 x 1/2 inch) to the Rear Panel of the MC1.2KW Amplifier. Refer to figures 7a and 7b.

Note: There are six openings on the bottom edge of the cover to allow the Loudspeaker's Cable to exit the MC1.2KW. The Rear Chassis Handle has tapped screw openings on both sides for securing the cover.

6. Connect the MC1.2KW power cord to an active AC outlet.

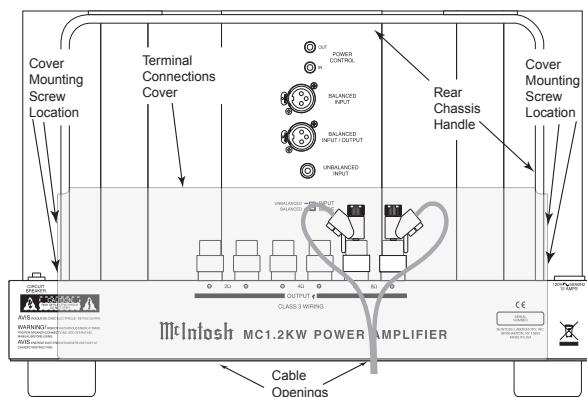

Figure 7a (Inside USA and Canada)

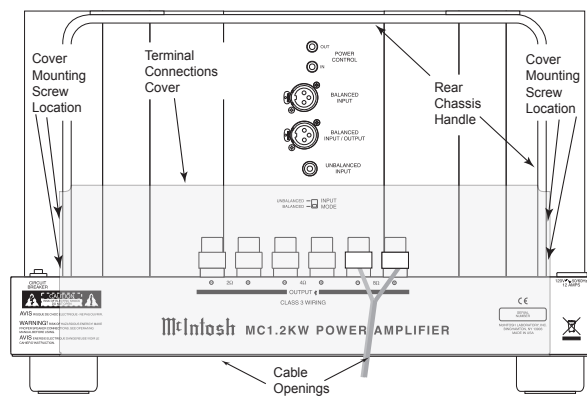
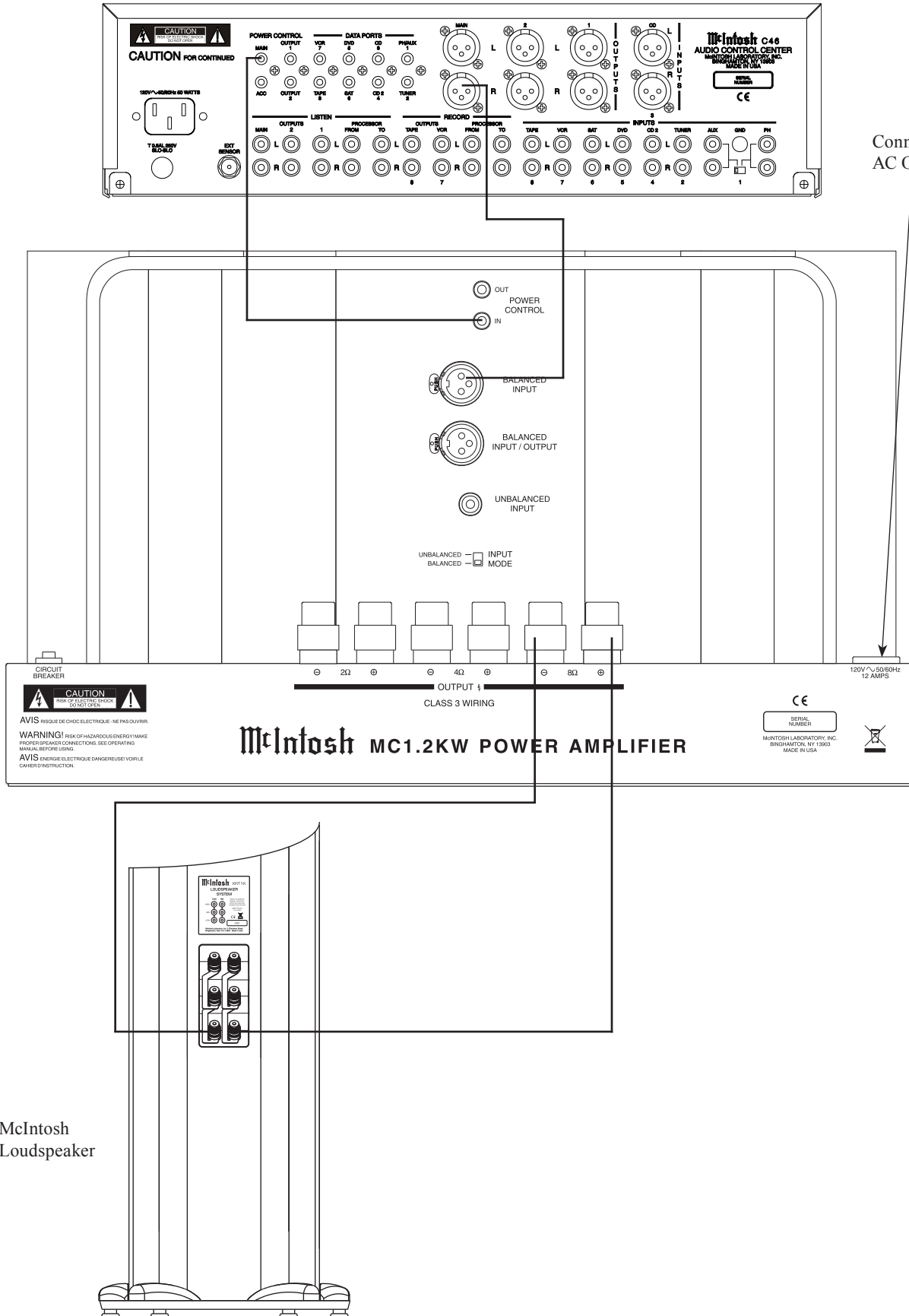

Figure 7b (Outside USA and Canada)

McIntosh Preamplifier



McIntosh Loudspeaker



How to Connect for Bi-Amp

Caution: The supplied AC Power Cord should not be connected to the Rear Panel of the MC1.2KW Amplifier until after the Loudspeaker Connections have been made and the supplied protective Terminal Connections Cover has been installed. Failure to observe this could result in Electric Shock.

1. For Remote Power Control, connect a power control cable from the Control Center or Preamplifier Power Control Out to the MC1.2KW (Amplifier One) POWER CONTROL IN.
2. Connect a power control cable from MC1.2KW (Amplifier One) POWER CONTROL OUT to the MC1.2KW (Amplifier Two) POWER CONTROL IN.
3. Connect a cable from the Balanced Output of a McIntosh Preamplifier or Control Center to the MC1.2KW (Amplifier One) BALANCED INPUT. Place the INPUT MODE Switch in the BALANCED Position.

Note: An optional hookup is to use an unbalanced cable and place the INPUT MODE Switch in the UNBALANCED Position.

4. Connect a cable from the BALANCED INPUT/OUTPUT of the MC1.2KW (Amplifier One) to the MC1.2KW (Amplifier Two) BALANCED INPUT.
5. Prepare the Loudspeaker Hookup Cable for attachment to the MC1.2KW Power Amplifier:

Bare wire cable ends:

Carefully remove sufficient insulation from the cable ends, refer to figures 1, 2 & 3. If the cable is stranded, carefully twist the strands together as tightly as possible.

Notes: 1. If desired, the twisted ends can be tinned with solder to keep the strands together.

2. Banana plugs are for use in the United States and Canada

only. In the United States, when using the 8 ohm

loudspeaker terminals, it is mandatory to use banana plugs inserted into the top hole of the loudspeaker terminals in order to comply with safety standard requirements.

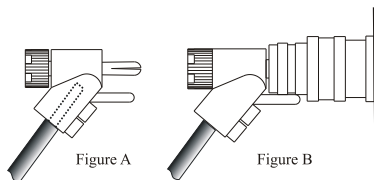
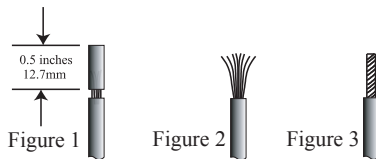

Connection Method for use inside the United States and Canada only:

Attach the previously prepared bare wire cable ends into the banana plugs and secure the connections. Insert the banana plug only into the hole at the top of the terminal.

Refer to figures A and B.

Connection Method for use outside the United States and Canada:

Attach the previously prepared bare wire cable ends into the spade lug connectors and secure the connections. Insert the spade lug connector or prepared section of the cable end into the terminal side access hole, and tighten the terminal cap until the cable is firmly clamped into the terminals so the lugs cannot slip out. Refer to figures 4, 5 & 6.

4. Connect the loudspeaker hookup cable to the output terminals that match the impedance of your loudspeaker, being careful to observe the correct polarities. Output impedance connections of 2 ohms, 4 ohms and 8 ohms are provided. If the impedance of your loudspeaker is in-between the available connections, use the nearest lower impedance connection.

WARNING: Loudspeaker terminals are hazardous live and present a risk of electric shock. For additional instruction on making Loudspeaker Connections contact your McIntosh Dealer or McIntosh Technical Support.

5. Attach the supplied Terminal Connections Cover with the four Phillips Head Mounting Screws (10-32 x 1/2 inch) to the Rear Panel of the MC1.2KW Amplifier. Refer to figures 7a and 7b (on the next page).

Note: There are six openings on the bottom edge of the cover to allow the Loudspeaker's Cable to exit the MC1.2KW. The Rear Chassis Handle has tapped screw openings on both sides for securing the cover.

6. Connect the MC1.2KW power cord to an active AC outlet.

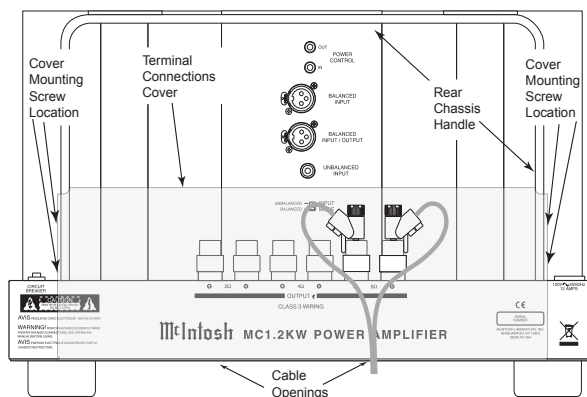
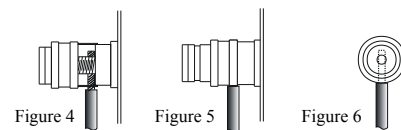

Figure 7a (Inside USA and Canada)

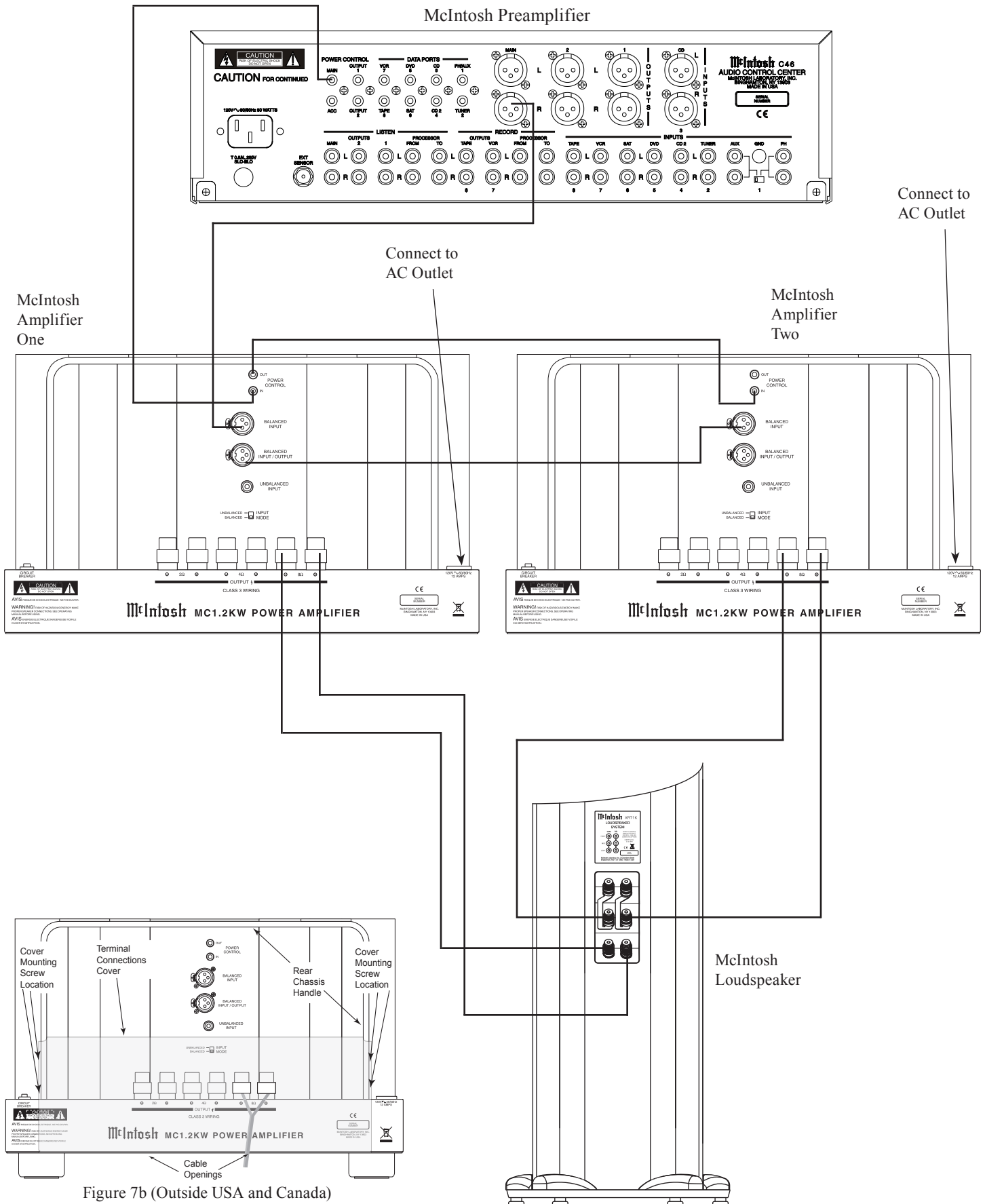
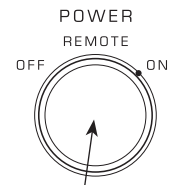
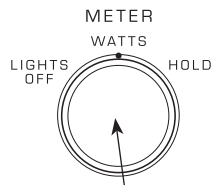
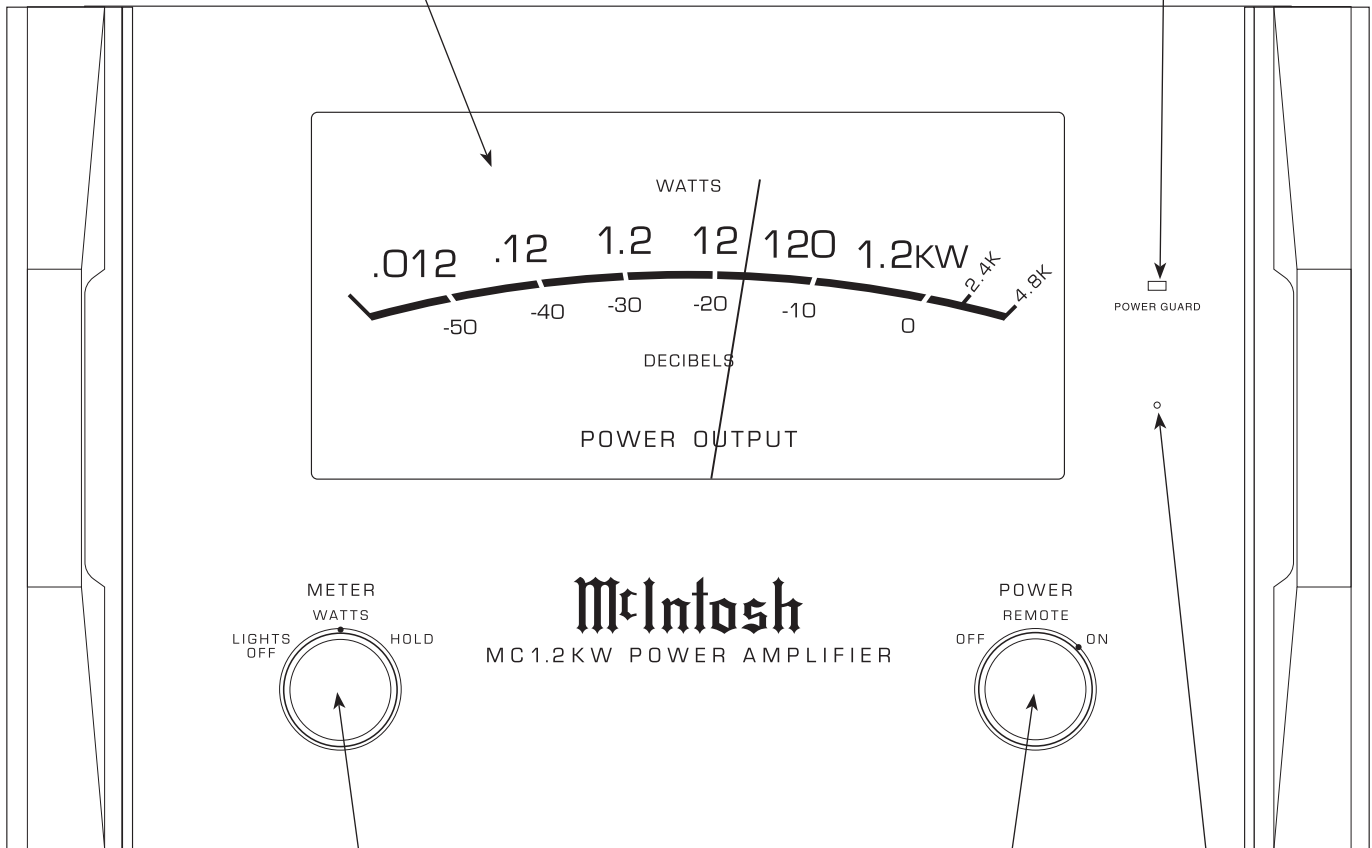

Figure 7b (Outside USA and Canada)



Meter indicates the Power Output of the Amplifier

LED indicates when Amplifier POWER GUARD circuit activates



METER Switch selects the display modes of the Power Output Meter and Meter Illumination

POWER Switch Turns AC Power On/Off, or On/Remote

Standby Power On Indicator

How to Operate

Power On

To have the MC1.2KW automatically turn On or Off when a control center turns on or off, rotate the power switch to the remote position. For manual operation, rotate the power switch to the On or Off position as desired. Refer to figure 8.

Note: There must be a power control connection between the MC1.2KW and the McIntosh Control Center, in order for the remote power turn-on to function.

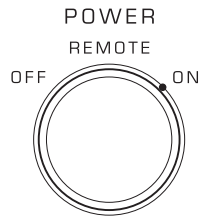

Figure 8

Meter Selection

Rotate the meter mode switch to select the meter operation mode you desire. Refer to figures 9 and 10.

Lights Off - Meter lights are turned off and the meter will continue to indicate the power output.

Note: When Power Control

Input of the MC1.2KW is connected to a McIntosh A/V Control Center or Preamplifier with Remote Meter Illumination Control, the Meter Illumination will automatically be remotely controlled (On/Off) with the METER Switch to set to the WATTS or HOLD position.

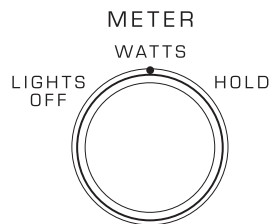

Figure 9

Watts- The meters respond to all the musical information being produced by the amplifier. They indicate to an accuracy of at least 95% of the power output with only a single cycle of a 2000Hz tone burst.

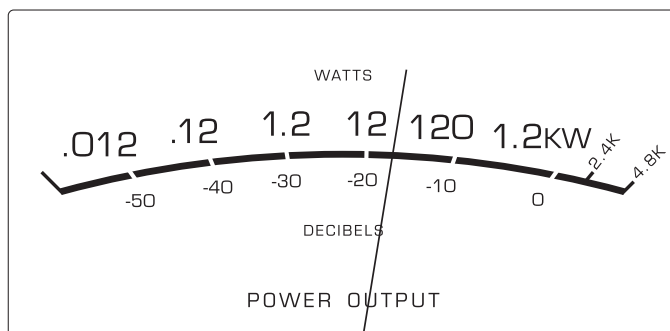

Figure 10

Hold - The meter pointer is locked to the highest power peak in a sequence of peaks. It is

electronically held to this power level until a higher power peak passes through the amplifier. The meter pointer will then rise to the newer higher indication. If no further power peaks are reached, the meter pointer will very slowly return to its rest position or lower power level. The decay rate is approximately 6dB per minute.

Note: The MC1.2KW Power Output Meter indicates the actual wattage delivered to the loudspeakers by responding to the combination of current and voltage output.

Input Mode Switch

The Input Mode Switch, which is located on the Rear Panel of the MC1.2KW, allows you to select either the Balanced or Unbalanced Input. Refer to figure 11.

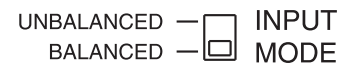

Figure 11



Technical Description

McIntosh Laboratory, the company who introduced the world's first amplifier that could be called "High Fidelity", has done it again. The McIntosh engineering staff has created a power amplifier without compromise, using the most advanced McIntosh circuit design concepts.

A continuous average power output rating of 1,200

watts and with an output current of 200 amperes, makes this not only the most advanced, but also the most powerful amplifier McIntosh has ever manufactured. The distortion limits for the MC1.2KW are no more than 0.005% at rated power output for all frequencies from 20Hz to 20,000Hz. Typical performance at mid frequen-



Top View of the MC1.2KW

cies is less than 0.002%. The true distortion readings on the MC1.2KW are so low, it takes special measuring techniques to make accurate readings. The MC1.2KW can deliver the best possible performance from any type of high quality loudspeaker system.

Creating an amplifier with this level of performance did not come easily. Many months of design, testing and measuring were required. Extensive controlled listening tests, the ultimate form of measuring, were made before the final design was accepted.

Design Philosophy

The design philosophy incorporated in the MC1.2KW involved several different techniques, all based on sound scientific logic. Every stage of voltage or current amplification must be as linear as possible prior to the use of negative feedback. McIntosh engineers know how to properly design negative feedback circuits so they contribute to the extremely low distortion performance expected from a McIntosh amplifier. The typical McIntosh owner would never accept the approximately 100 times higher distortion of many non-feedback designs.

Double Balanced Push-Pull design is used from input to output. Each half of the amplifier contains complimentary balanced circuitry. The resulting double balanced configuration cancels even order distortion. Refer to figure 12.

All transistors are selected to have nearly constant current gain over the entire current range they must cover. Output transistors in particular, have matched uniform current gain, high current bandwidth product and large

active region safe operating area. An automatic tracking bias system completely eliminates any trace of crossover distortion. Precision metal film resistors and low dielectric absorption film capacitors are used in all critical circuit locations.

The output signals of the two balanced circuits are coupled together in the unique McIntosh MC1.2KW Output Autoformer. It provides low distortion power transfer at frequencies from below 20Hz to well beyond 20,000Hz with optimum impedance points of two ohms, four ohms and eight ohms. The unequalled expertise of McIntosh in the design and manufacturing of autoformers is legendary in the high fidelity industry.

The high efficiency circuit design of the MC1.2KW contributes to low operating temperatures. More than 2800 square inches of heat sink

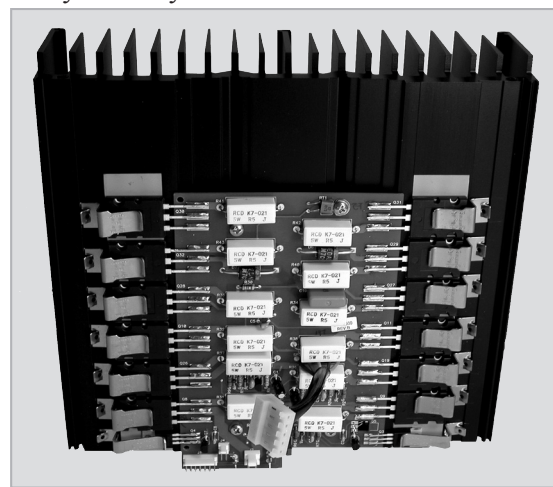

Figure 13

area keep the MC1.2KW operating safely with convection cooling. No fans are needed. Refer to figure 13.

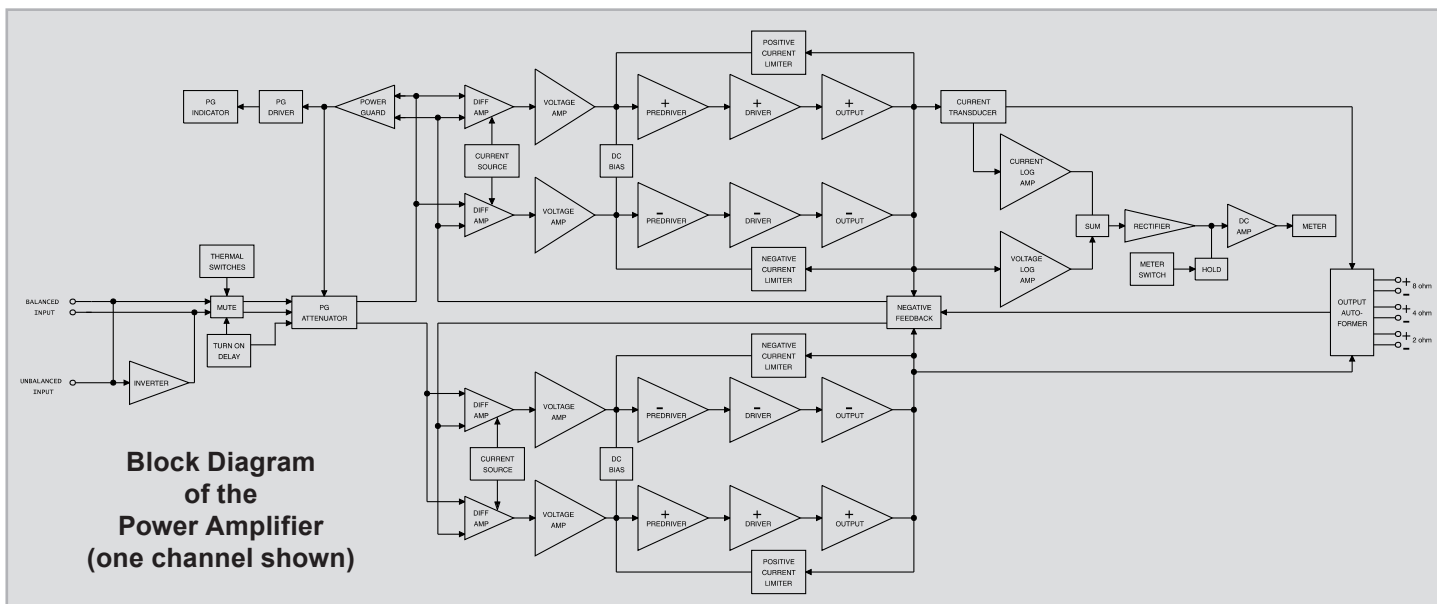

Figure 12

Autoformers

All solid state power amplifier output circuits work best into what is called an optimum load. This optimum load may vary considerably from what a loudspeaker requires. In the case of more than one loudspeaker connected in parallel, the load to the power amplifier may drop to two ohms or even less. A power amplifier connected to a load that is lower than optimum, causes more output current to flow, which results in extra heat being generated in the power output stage. This increase in temperature will result in a reduced life expectancy for the amplifier.

The special Balanced Dual Core Autoformer creates an ideal match between the power amplifier output stage and the loudspeaker. A McIntosh amplifier with an Autoformer can be used to safely drive multiple speakers without reducing the life expectancy of the power amplifier. Refer to figure 14.



Figure 14

There is absolutely no performance limitation with an Autoformer. Its frequency response exceeds that of the output circuit itself, and extends well beyond the audible range. Its distortion level is so low it is virtually impossible to measure.

In the rare event of a power amplifier output circuit failure, the McIntosh Autoformer provides absolute protection from possible damage to your valuable loudspeakers. The unequalled expertise of McIntosh in the design and manufacturing of Autoformers is legendary in the high fidelity industry. McIntosh engineers know how to do it right.

Power Output Meter

The McIntosh MC1.2KW has a huge hand built Output Watt Meter that responds 95% full scale to a single cycle

tone burst at 2kHz. Refer to figure 15. Voltage and current outputs are electronically measured, multiplied and fed to a special circuit that accelerates

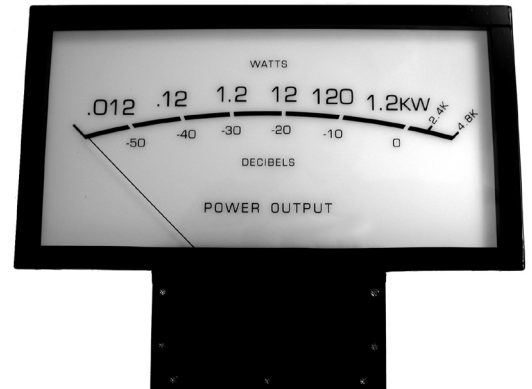

Figure 15

the pointer movement in the upward direction. When the pointer reaches its peak it pauses only long enough for the human eye to perceive its position, then drops. It is almost 10 times faster than a professional VU meter.

A front panel switch is provided to change the meter to the Watts Hold Mode of operation. This allows fast upward movement of the pointer but greatly increases Hold Time at the peak of its travel. The highest power output of the source material is thus recorded.

Protection Circuits

The MC1.2KW incorporates a version of the McIntosh Sentry Monitor Output Transistor Protection Circuit. Refer to Figure 16. There is absolutely no compromise in sonic performance with this circuit, and it ensures safe operation of the amplifier under even the most extreme operating conditions.

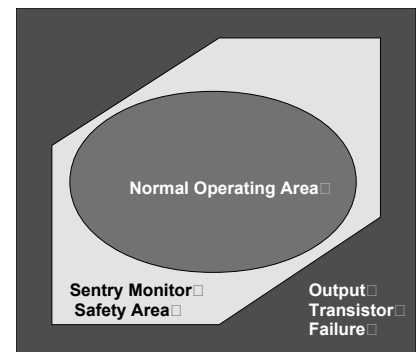

Figure 16

The different types of protection circuits incorporated in the MC1.2KW insure a long and safe operating life. This is just one of the many characteristics of McIntosh Power Amplifiers that make them world famous.

The MC1.2KW also includes the unique patented McIntosh Power Guard circuit. Power Guard eliminates the possibility of ever overdriving the amplifier into clipping. Refer to figures 17, 18 and 19. An overdriven amplifier can produce both

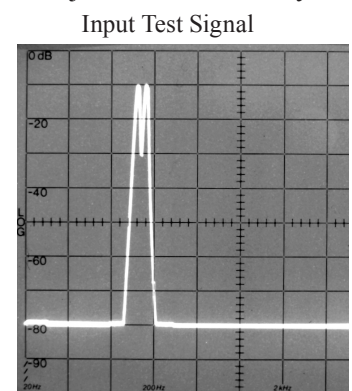

Figure 17

audible and inaudible distortion levels exceeding 40%. The audible distortion is unpleasant to hear, but the inaudible ultrasonic distortion is also undesirable, since it can damage valuable loudspeaker system tweeters. You will never experience the harsh and damaging distortion due to clipping.

The Power Guard circuit is a waveform comparator, monitoring both the input and output waveforms. Under normal operating conditions, there are no differences between the shape of these waveforms. If an amplifier channel is overdriven, there will be a difference between the two signal waveforms. When the difference exceeds 0.3%, the Power Guard activates the PG light and a dynamic electronic attenuator at the amplifier input reduces the input volume just enough to prevent any further increase in distortion. The Power Guard circuit acts so fast that there are absolutely no audible side effects and the sonic purity of the music reproduction is perfectly preserved. The MC1.2KW Power Amplifier with Power Guard is not limited to just the rated power output, but will actually produce distortion free output well above its rated power due to the McIntosh philosophy of conservative design.

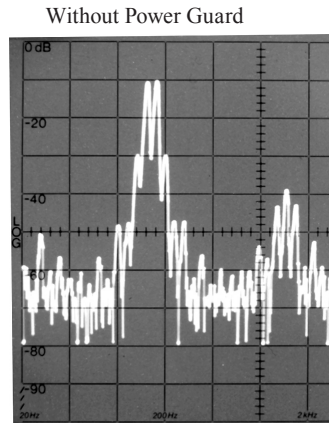

Figure 18

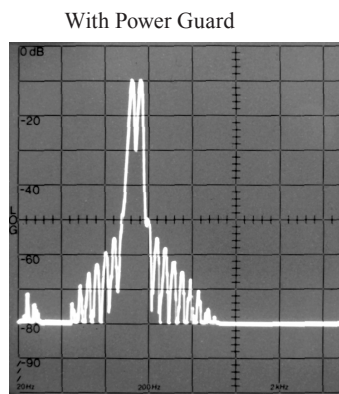

Figure 19

Power Supply Circuits

To compliment the fully balanced design of the MC1.2KW there are two high voltage power supplies; one for each

of the two amplifier circuits, allowing each amplifier circuit to be optimized using its own power supply. Refer to figure 20.

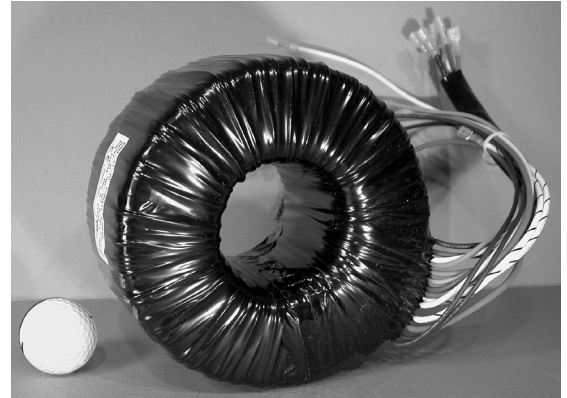

Figure 21

High power amplifiers draw high current from the AC power line. The very large Power Transformer, has toroidal windings on a toroidal core and can supply over 35 amps of continuous current. Refer to figure 21 (golf ball is for size comparison). It is enclosed in the legendary McIntosh Potted Enclosures and weighs over 12.06kg. The super size main filter capacitors can store over 600 Joules of energy for the five amplifier channels, necessary for the wide dynamic range that "Digital Audio" demands. The power amplifier draws high current from the AC power line. Therefore, it is important that they plug directly into the wall outlet. Also, most owners desire one power switch for the whole audio system. The MC1.2KW is equipped with a circuit that provides remote Power Control from a McIntosh A/V Control Center. When the A/V Control Center is switched On, a (+5V) signal operates the power relay in the MC1.2KW. The MC1.2KW also has a remote Power Control Out Jack. The Power Control signal from this jack is delayed by a fraction of a second so that the turn on power surge of the next power amplifier occurs at a later time. This helps prevent power circuit overload that could trip circuit breakers or blow fuses, a very important feature in a high power Home Theater System employing three or more MC1.2KW Power Amplifiers.

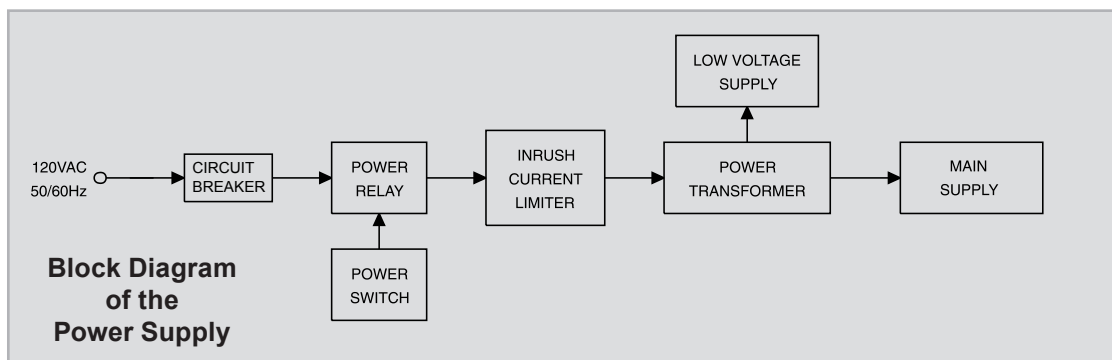

Figure 20



Specifications

Power Output

Minimum sine wave continuous average power output is:
1,200 watts into 2 ohm load
1,200 watts into 4 ohm load
1,200 watts into 8 ohm load

Output Load Impedance

2, 4 or 8 ohms

Rated Power Band

20Hz to 20,000Hz

Total Harmonic Distortion

0.005% maximum harmonic distortion at any power level from 250 milliwatts to rated power, 20Hz to 20,000Hz

Dynamic Headroom

2dB

Frequency Response

+0, -0.25dB from 20Hz to 20,000Hz
+0, -3dB from 10Hz to 100,000Hz

Input Sensitivity (for rated output)

2.5 Volt Unbalanced
5 Volt Balanced

Signal To Noise Ratio (A-Weighted)

120dB below rated output, Unbalanced
124dB below rated output, Balanced

Intermodulation Distortion

0.005% maximum, if the instantaneous peak power output does not exceed twice the rated power output for any combination of frequencies from 20Hz to 20,000Hz.

Wide Band Damping Factor

Greater than 40

Input Impedance

10,000 ohms

Power Guard

Less than 2% THD with up to 14dB overdrive at 1,000Hz

Power Requirements

100 Volts, 50/60Hz at 15 Amps
110 Volts, 50/60Hz at 12.5 Amps
120 Volts, 50/60Hz at 12 Amps
220 Volts, 50/60Hz at 7.5 Amps
230 Volts, 50/60Hz at 6.5 Amps
240 Volts, 50/60Hz at 6.5 Amps
Standby: 0.5 watts

Note: Refer to the rear panel of the MCI.2KW for the correct voltage.

Overall Dimensions

Width is 17-3/4 inches (45.09cm)
Height is 12-5/16 inches (31.27cm) including feet
Depth is 22 inches (55.88cm) including the Front Panel and Cables

Weight

147 pounds (66.7 kg) net, 172 pounds (78.0 kg) in shipping carton

Shipping Carton Dimensions

Width is 31 inches (78.74cm)
Depth is 28 inches (71.12cm)
Height is 17-1/4 inches (43.82cm)

Packing Instructions

In the event it is necessary to repack the equipment for shipment, the equipment must be packed exactly as shown below. It is very important that the four feet are attached to the bottom of the equipment. This will ensure the proper equipment location on the bottom foam pad. Failure to do this will result in shipping damage.

Use the original shipping carton and interior parts only if they are all in good serviceable condition. If a shipping carton or any of the interior part(s) are needed, please call or write Customer Service Department of McIntosh Laboratory. Please see the Part List for the correct part numbers.

Quantity	Part Number	Description
1	034105	Shipping carton top
1	034104	Shipping carton bottom
2	034349	Foam Pad (top and bottom)
3	034350	Foam Ring
4	400159	10-32 x 3/4 inch screw
4	018445	Feet

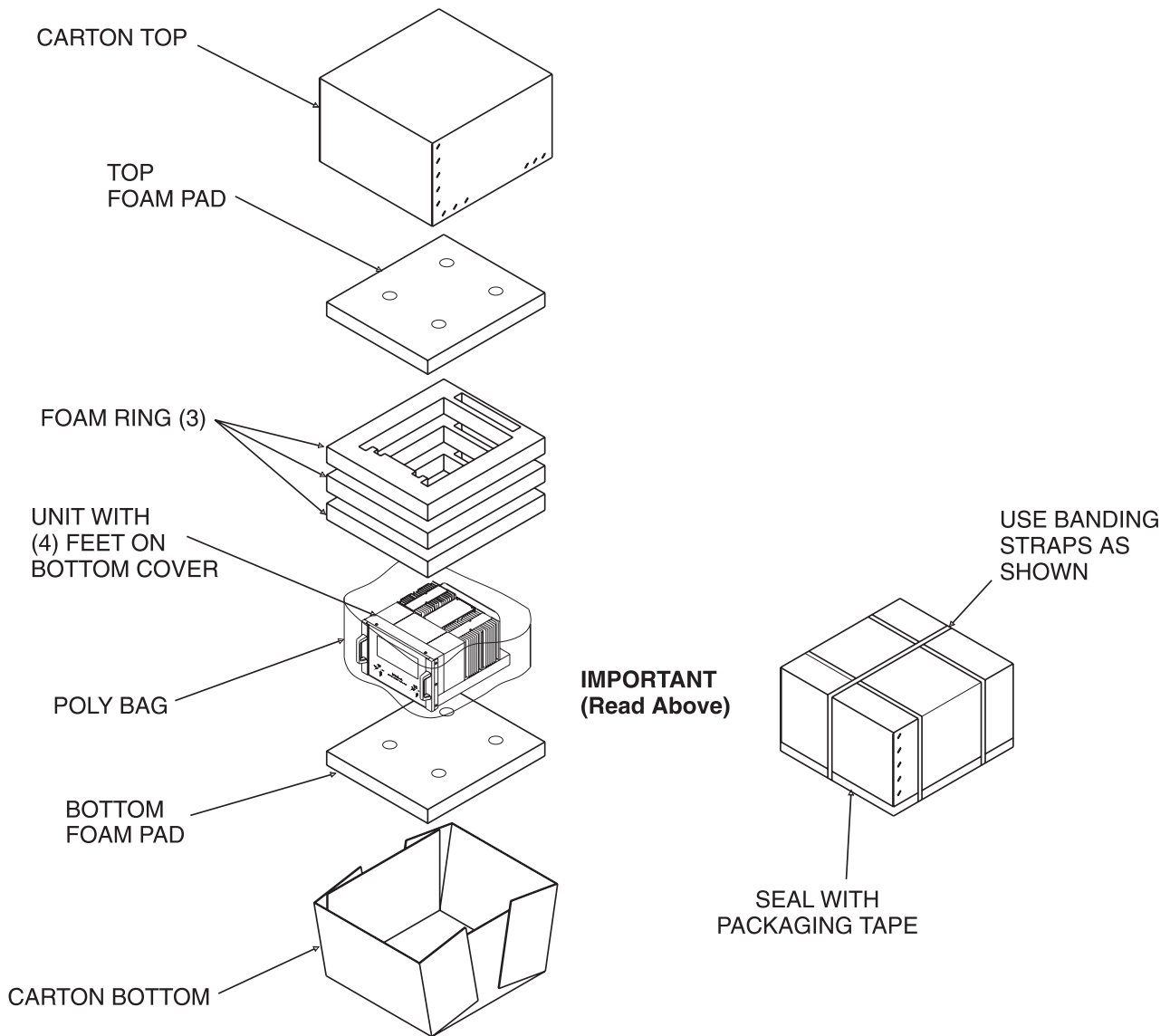



McIntosh Laboratory, Inc.
2 Chambers Street
Binghamton, NY 13903

The continuous improvement of its products is the policy of McIntosh Laboratory Incorporated who reserve the right to improve design without notice. Printed in the U.S.A.

McIntosh Part No. 04105500