

McIntosh

MI-350

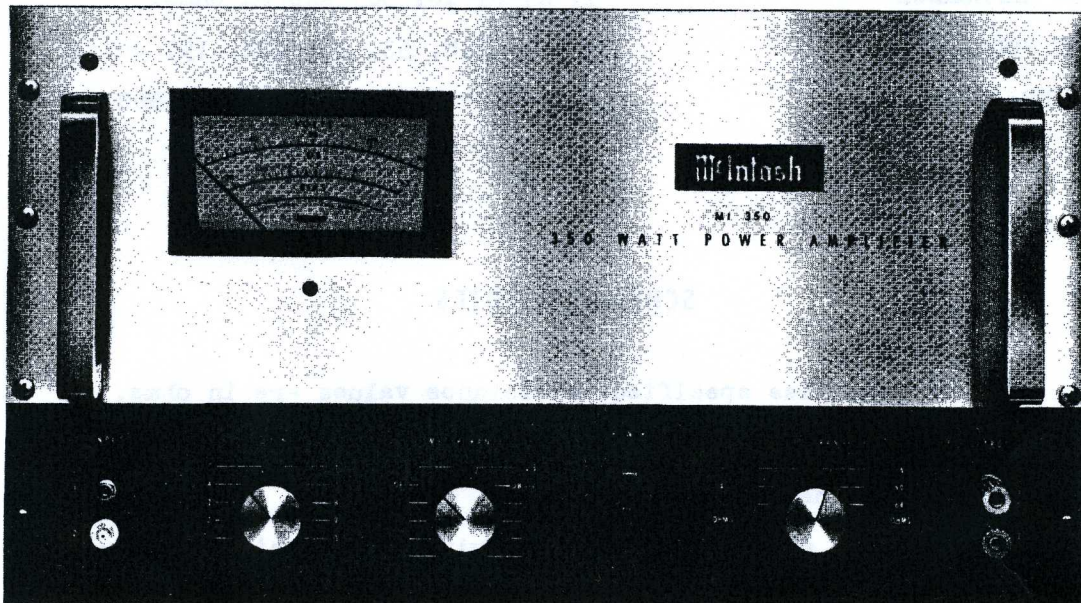

SERVICE INFORMATION

STARTING WITH SERIAL NO. 10R01

MI-350

ELECTRICAL SPECIFICATIONS

POWER OUTPUT	350 watts continuous at 8, 16, 50, 64 ohms, 325 watts continuous at 4 ohms, 300 watts continuous at 1 ohm.
FREQUENCY RESPONSE	20Hz to 20kHz +0, -0.5dB at 350 watts output. 1Hz to 70kHz +0, -3dB at 1 watt output.
HARMONIC DISTORTION	Less than 0.15% at rated output or less, 20Hz to 20kHz.
INTERMODULATION DISTORTION	Less than 0.15%
NOISE AND HUM LEVEL	-95dB
INPUT LEVEL	1.1 volt
OUTPUT IMPEDANCE	1, 4, 8, 16, 50, and 64 ohms.
OUTPUT VOLTAGES	17.3, 35.8, 53, 75, 132, 150 volts.
AC POWER INPUT	117/125 volts, 50/60Hz, 400-900 watts.

SCHEMATIC NOTES

1. Unless otherwise specified, resistance values are in ohms, 1/2 watts, and 10% tolerance. Capacitance values smaller than 1 are in microfarads (μF); values greater than 1 are in picofarads (pF). Inductors, unless otherwise specified, are in microhenries (μH).
2. The terminal numbering of rotary switches and printed circuit board wires is for reference only.
3. All voltages are measured under the following conditions:
Use of an 11 megohm input impedance VTVM voltmeter.
All voltages $\pm 10\%$ with respect to chassis ground.
No signal at input terminals.
AC input at 117 volts, 50/60 cycles.
Front panel controls at:

gain	fully counterclockwise
meter range	off
power	on
output range	fully counterclockwise
4. In units with serial Numbers below 10R54: L1 through L8 are not used; R114 is 820 Ω 5% 1/2W; and C207D is used.

METER SECTION PRINTED CIRCUIT BOARD 043-768

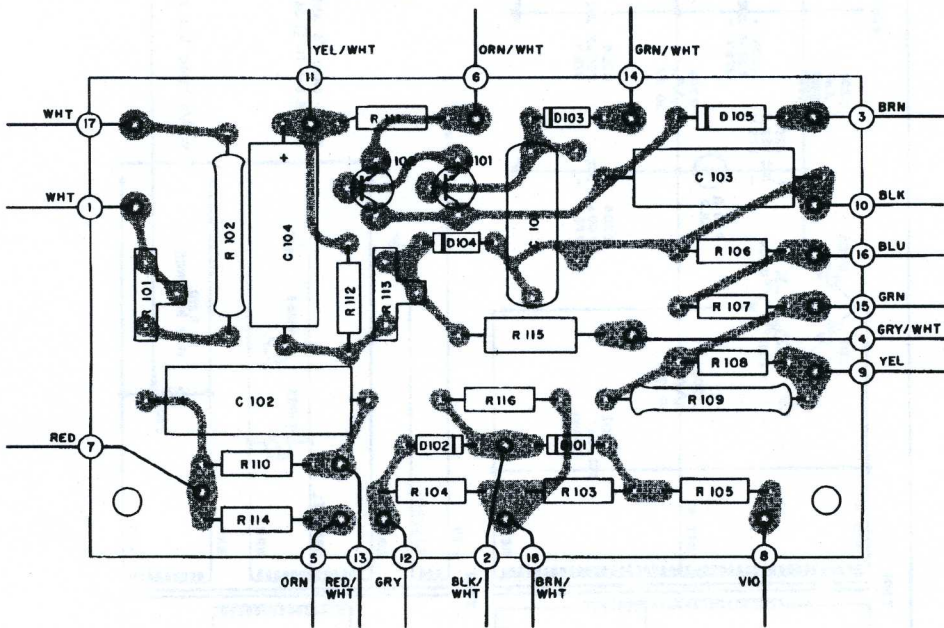

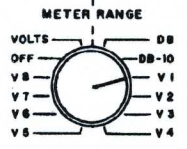
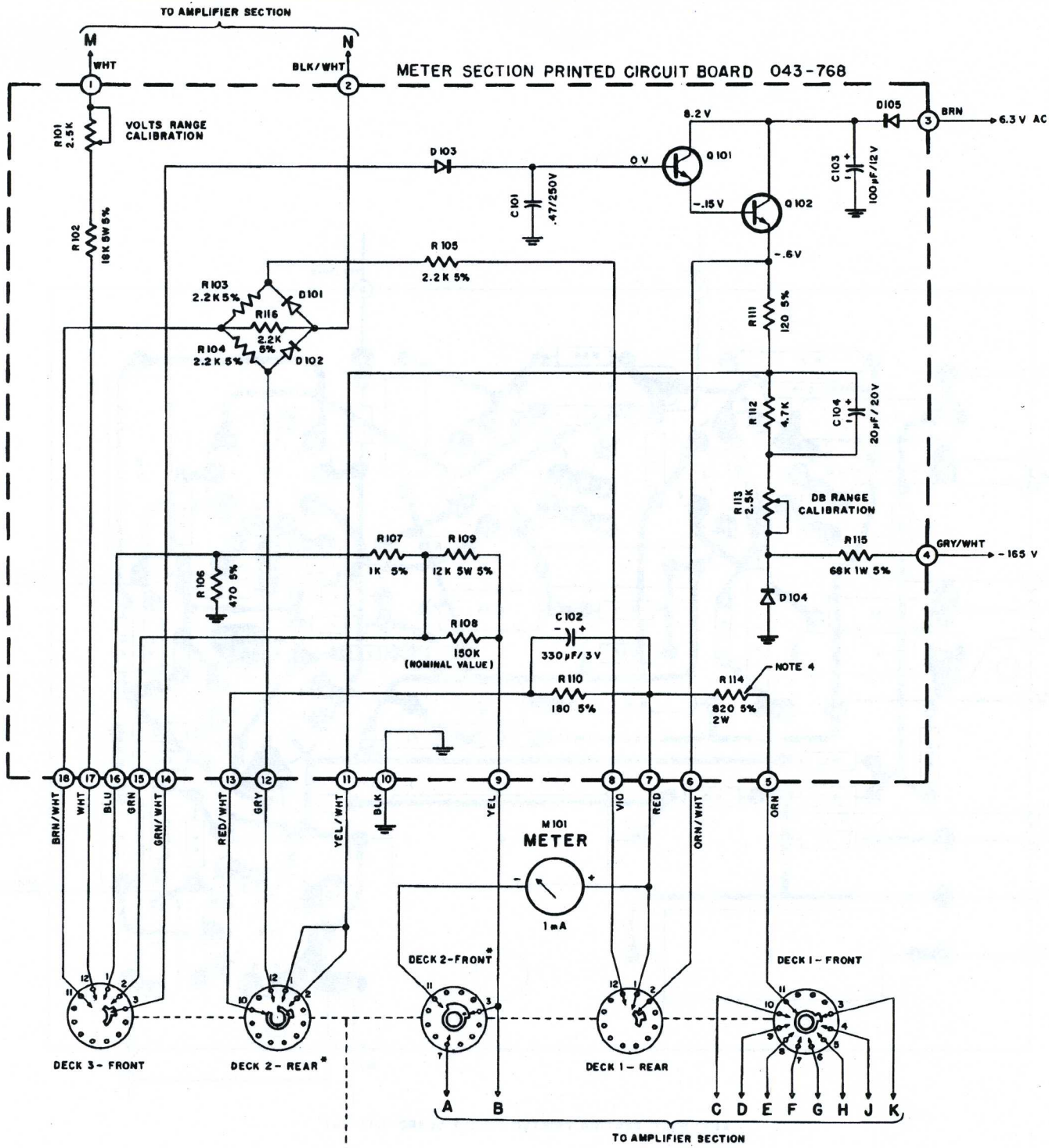

* - ROTORS ARE INTERCONNECTED

METER SECTION

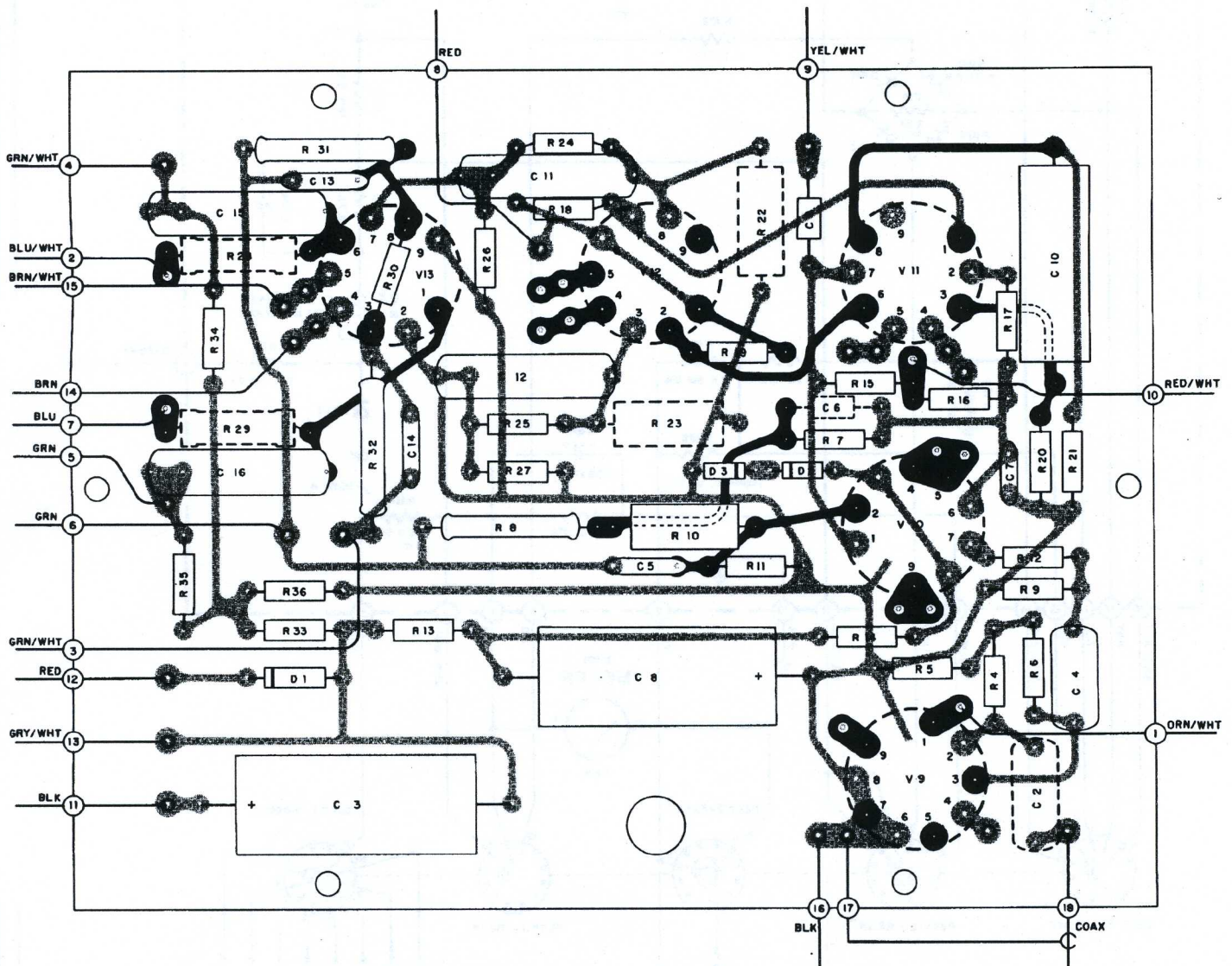

AMPLIFIER SECTION PRINTED CIRCUIT BOARD 043-767

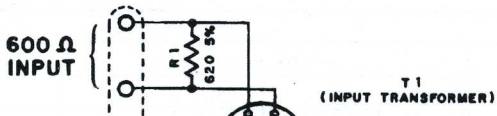

V9
12AX7/ECC83

V10
12AX7/ECC83

VII
6DJ8/ECC88 6

AMPLIFIER SECTION PRINTED CIRCUIT BOARD 043-

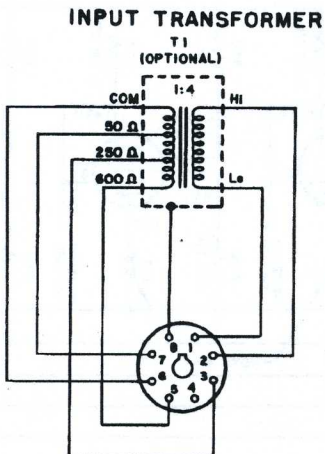
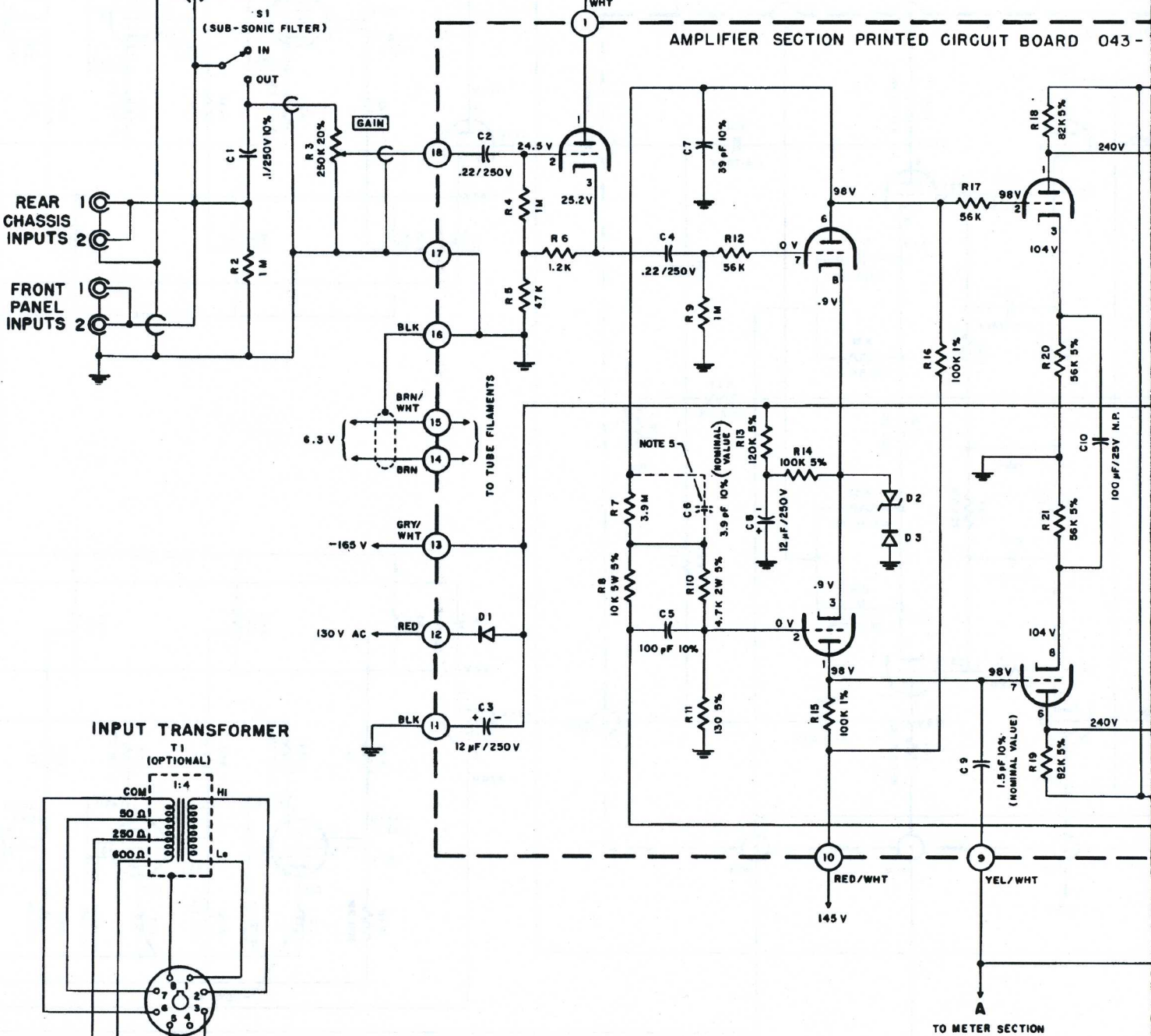

V14
6BL7GTA

V5
6LQ6/6JE6B

V6
6LQ6/6JE6B

V7
6LQ6/6J

V12
6CG7/6FQ7

V13
6DJ8/ECC88

043 - 767

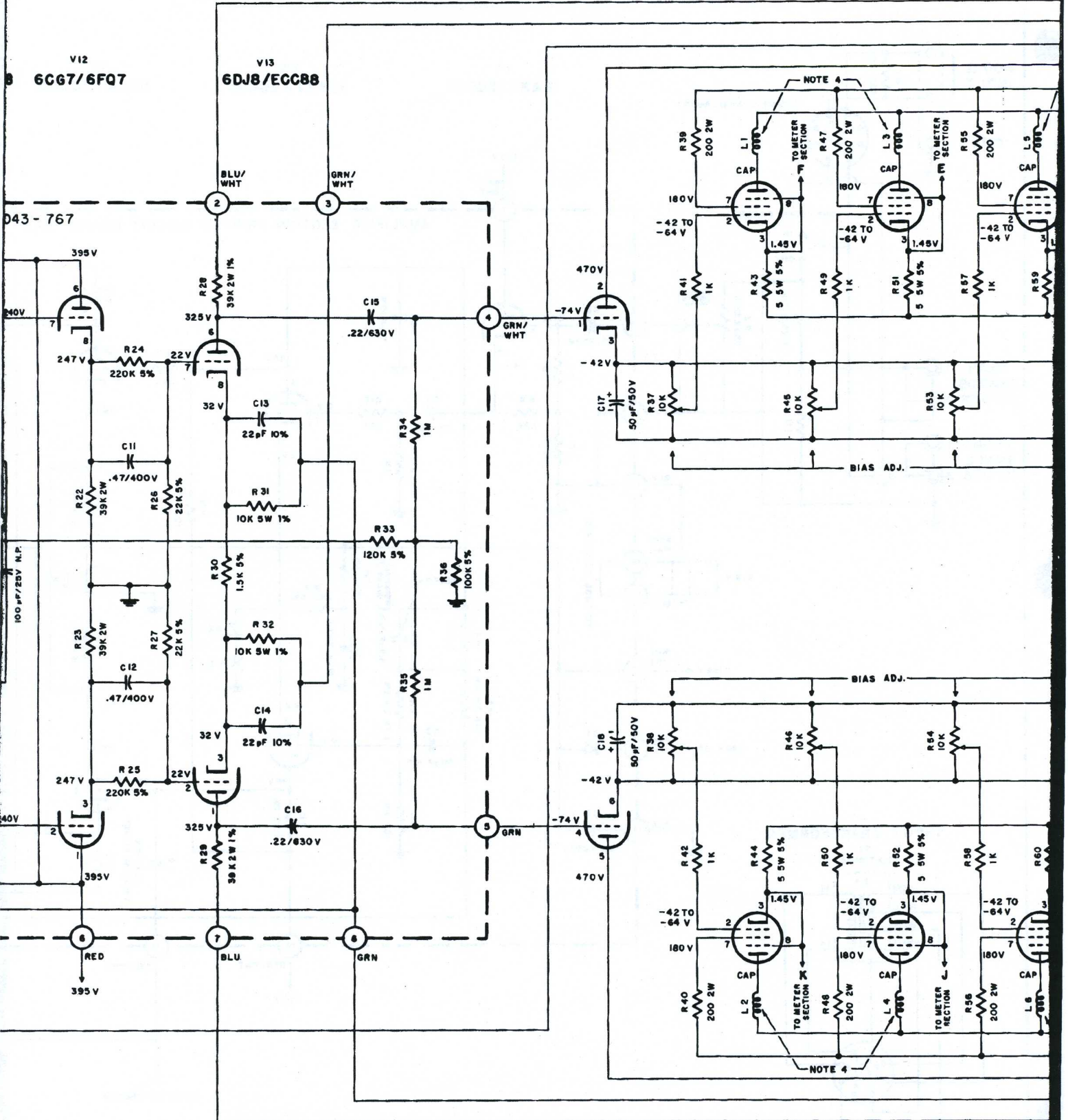

V1
6LQ6/6JE6B

V2
6LQ6/6JE6B

V3
6LQ6/6J

6B V7 6LQ6/6JE6B V8 6LQ6/6JE6B

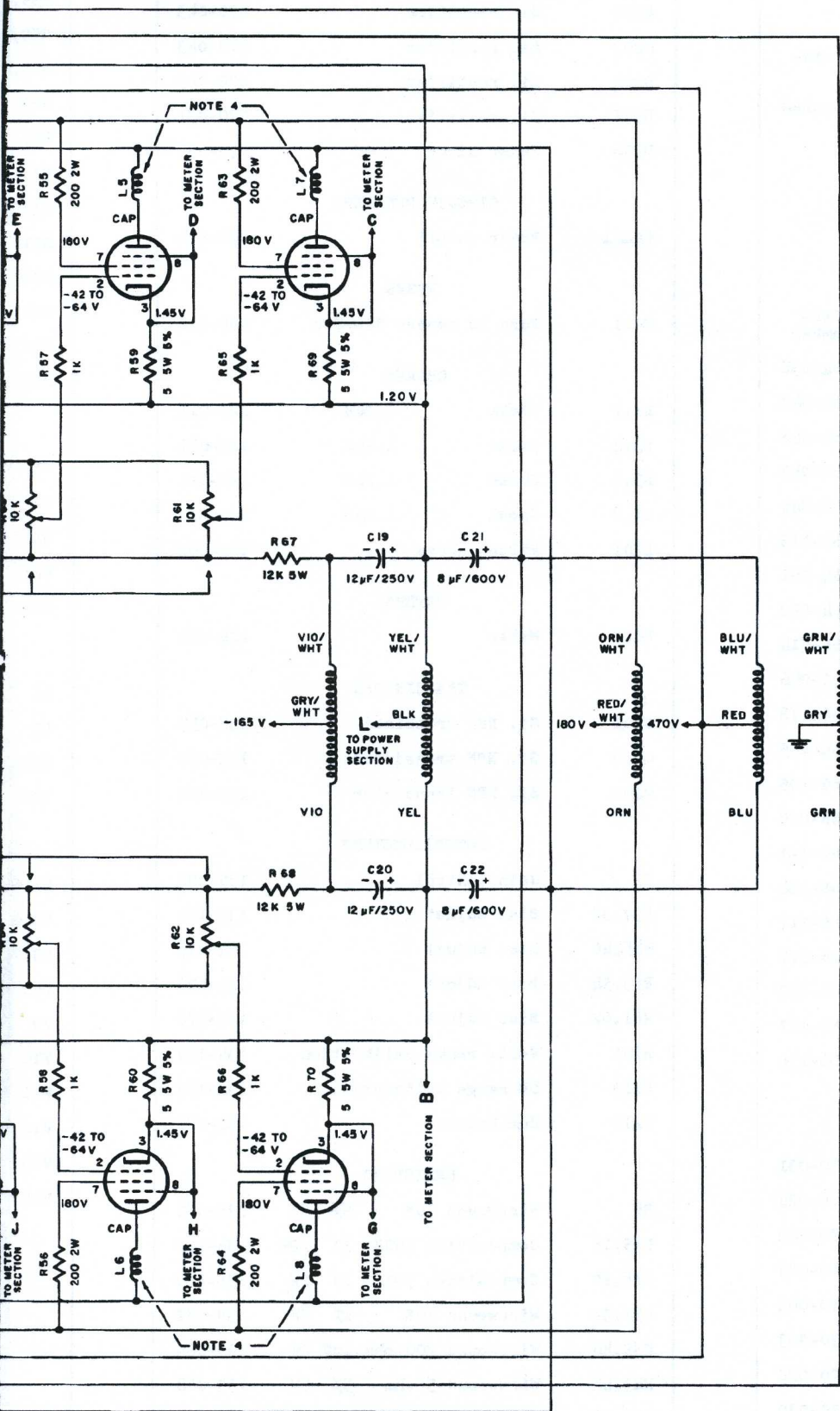

6B V3 6LQ6/6JE6B V4 6LQ6/6JE6B

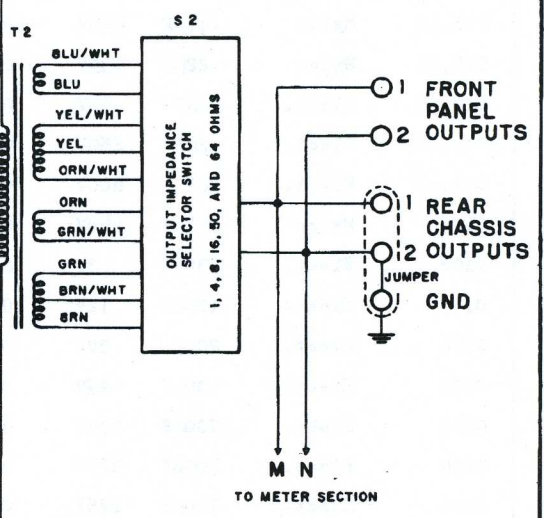

AMPLIFIER SECTION

REPLACEMENT PARTS

All parts not listed are common items obtainable from radio parts jobbers.

Replacement parts may be obtained when ordered by PART NUMBER from:

McIntosh Laboratory Inc.
Customer Service Department
2 Chambers Street
Binghamton, New York 13903
(telephone 607-723-3512)

CAPACITORS

Symbol Number	Description	Part Number
C1	Mylar .1 μ F 250V 10%	064-038
C2	Mylar .22 μ F 250V	064-043
C3	Elect. 12 μ F 250V	066-046
C4	Mylar .22 μ F 250V	064-043
C8	Elect. 12 μ F 250V	066-046
C10	Elect. 100 μ F 25V NP	066-115
C11,12	Mylar .47 μ F 400V	064-051
C15,16	Mylar .22 μ F 630V	064-052
C17,18	Elect. 50 μ F 50V	066-014
C19,20	Elect. 12 μ F 250V	066-046
C21,22	Elect. 8 μ F 600V	066-118
C101	Mylar .47 μ F 250V	064-045
C102	Elect. 330 μ F 3V	066-105
C103	Elect. 100 μ F 12V	066-018
C104	Elect. 20 μ F 20V	066-121
C201	Elect. 100 μ F 25V	066-124
C203	Elect. 700 μ F 275V	066-117
C204	Elect. 700 μ F 275V	066-117
C205	Elect. 700 μ F 275V	066-117
C206	Elect. 700 μ F 275V	066-117
C207	Elect. 100/30/30/30 μ F 450/300/250/250V	066-116

DIODES

D1	Si. rectifier	070-031
D2	Zener diode 10V	070-024
D3	Si. signal diode	070-022
D101	Ge. signal diode	070-003
D102	Ge. signal diode	070-003
D103	Ge. signal diode	070-003
D104	Si. signal diode	070-022
D105	Si. rectifier	070-030
D201	Si. rectifier	070-043

D202	Si. rectifier	070-043
D203	Si. rectifier	070-043
D204	Si. rectifier	070-043
D205	Si. rectifier	070-031
D206	Zener diode 180V	070-037

CIRCUIT BREAKERS

CB201	Power on-off	088-004
-------	--------------	---------

FUSES

F201	Fuse 10 ampere Slo-Blo	089-018
------	------------------------	---------

CHOKES

L1,2	Choke 1.2 μ H	122-011
L3,4	Choke 1.2 μ H	122-011
L5,6	Choke 1.2 μ H	122-011
L7,8	Choke 1.2 μ H	122-011
L201	Filter choke	122-061

METERS

M101	Meter	124-014
------	-------	---------

TRANSISTORS

Q101	Si. NPN transistor	132-057
Q102	Si. NPN transistor	132-057
Q201	Si. NPN transistor	132-059

POTENTIOMETERS

R3	Gain control	134-192
R37,38	Bias adjust	134-176
R45,46	Bias adjust	134-176
R53,54	Bias adjust	134-176
R61,62	Bias adjust	134-176
R101	Volt. range calibration	134-197
R113	DB range calibration	134-197
R210	Hum balance	134-086

RESISTORS

R8	Wirewound 10K 5% 5W	139-051
R15,16	Composition 100K 1% 1/2W	136-468
R28,29	Composition 39K 1% 2W	136-467
R31,32	Wirewound 10K 1% 5W	139-052
R39,40	Wirewound 200 ohm 10% 2W	139-069
R43,44	Wirewound 5 ohm 5% 5W	139-068
R47,48	Wirewound 200 ohm 10% 2W	139-069
R51,52	Wirewound 5 ohm 5% 5W	139-068

R55,
R59,
R63,
R67,
R69,
R102
R109
R114
R201
R202
R203
R204

S1
S2
S101
S201
S202

T1
T2
T201
T202

V1,5
V2,6
V3,7
V4,8
V9
V10
V11
V12
V13
V14

R55,56	Wirewound 200 ohm 10% 2W	139-069
R59,60	Wirewound 5 ohm 5% 5W	139-068
R63,64	Wirewound 200 ohm 10% 2W	139-069
R67,68	Wirewound 12K 10% 5W	139-053
R69,70	Wirewound 5 ohm 5% 5W	139-068
R102	Wirewound 18K 5% 5W	139-062
R109	Wirewound 12K 5% 5W	139-063
R114	Wirewound 820Ω 5% 2W	139-072
R201	Wirewound 1.5K 10% 20W	139-064
R202	Wirewound 30 ohm 10% 5W	139-067
R203	Thermistor	144-006
R204	Wirewound 30 ohm 10% 5W	139-067

SWITCHES

S1	Sub-sonic filter switch	148-002
S2	Output impedance switch	146-113
S101	Meter range switch	146-112
S201	Line voltage switch	149-006
S202	Thermal cut-out	153-010

TRANSFORMERS

T1	Input transformer	159-001
T2	Output transformer	043-766
T201	Power trans (high voltage)	043-765
T202	Power trans (low voltage)	043-764

TUBES

V1,5	6LQ6/6JE6B	165-059
V2,6	6LQ6/6JE6B	165-059
V3,7	6LQ6/6JE6B	165-059
V4,8	6LQ6/6JE6B	165-059
V9	12AX7/ECC83	165-019
V10	12AX7/ECC83	165-019
V11	6DJ8/ECC88	165-056
V12	6CG7/6FQ7	165-057
V13	6DJ8/ECC88	165-056
V14	6BL7GTA	165-058

FRONT PANEL & TRIM

Front panel	002-027
Side frame (right)	043-830
Side frame (left)	043-831
Front panel handles	020-026
Gain knob	090-079
Meter range knob	090-079

Output range knob	090-079
Meter bezel	020-022

LAMPS

#1855 (METER)	058-030
---------------	---------

MISCELLANEOUS ITEMS

Shipping crate	043-832
Owners manual	038-243
Line cord	170-038
Fuseholder	178-001
Hardware package	043-799
Cooling fan	098-135
Cooling fan guard	098-136

McIntosh SERVICE BULLETIN

MC 3500/MI-350
S.B. No. 2

ELIMINATION OF SELF TURN-OFF

MODEL: MC 3500/MI-350 Power Amplifier

PURPOSE OF MODIFICATION: To prevent amplifier from turning off at maximum output.

WHAT UNITS ARE AFFECTED: MC 3500 Serial No. 10N01 & Above
MI-350 Serial No. 10R01 & Above

WHEN MODIFICATION SHOULD BE MADE: Any time any service is performed, or if customer complains that the amplifier will not remain on.

McINTOSH MODIFICATION KIT NO.: No kit.

PARTS REQUIRED:

QUANTITY	PART NUMBER	DESCRIPTION
1	139-069	200 Ω 2W wirewound resistor

PROCEDURE:

- Step 1 Remove bottom cover.
- Step 2 Add resistor in parallel with capacitor C201 (shown at circuit breaker on schematic).
- Step 3 Replace bottom cover.

MC 3500/MI-350
S.B. No. 2