



## Power Controller



## MPC1500 Owner's Manual

Torus Power Technology under license from Plitron Manufacturing Inc.

The lightning flash with arrowhead, within an equilateral triangle, is intended to alert the user to the presence of uninsulated “dangerous voltage” within the product’s enclosure that may be of sufficient magnitude to constitute a risk of electric shock to persons.



**AVIS** RISQUE DE CHOC ELECTRIQUE - NE PAS OUVRIR.

The exclamation point within an equilateral triangle is intended to alert the user to the presence of important operating and maintenance (servicing) instructions in the literature accompanying the appliance.

**WARNING - TO REDUCE RISK OF FIRE OR ELECTRICAL SHOCK, DO NOT EXPOSE THIS EQUIPMENT TO RAIN OR MOISTURE.**

**NO USER-SERVICEABLE PARTS INSIDE. REFER SERVICING TO QUALIFIED PERSONNEL.**

To prevent the risk of electric shock, do not remove cover or back. No user-serviceable parts inside.

## IMPORTANT SAFETY INSTRUCTIONS!

**PLEASE READ THEM BEFORE OPERATING THIS EQUIPMENT.**

1. Read these instructions.
2. Keep these instructions.
3. Heed all warnings.
4. Follow all instructions.
5. Do not use this apparatus near water.
6. Clean only with a dry cloth.
7. Do not block any ventilation openings. Install in accordance with the manufacturer’s instructions.
8. Do not install near any heat sources such as radiators, heat registers, stoves, or other apparatus (including amplifiers) that produce heat.
9. Do not defeat the safety purpose of the polarized or grounding-type plug. A polarized plug has two blades with one wider than the other. A grounding type plug has two blades and a third grounding prong. The wide blade or the third prong are provided for your safety. If the provided plug does not fit into your outlet, consult an electrician for replacement of the obsolete outlet.
10. Protect the power cord from being walked on or pinched particularly at plugs, convenience receptacles, and the point where they exit from the apparatus.
11. Only use attachments/accessories specified by the manufacturer.
12. Use only with the cart, stand, tripod, bracket, or table specified by the manufacturer, or sold with the apparatus. When a cart is used, use caution when moving the cart/apparatus combination to avoid injury from tip-over. 
13. Unplug this apparatus during lightning storms or when unused for long periods of time.
14. Refer all servicing to qualified service personnel. Servicing is required when the apparatus has been damaged in any way, such as power-supply cord or plug is damaged, liquid has been spilled or objects have fallen into the apparatus, the apparatus has been exposed to rain or moisture, does not operate normally, or has been dropped.
15. Do not expose this equipment to dripping or splashing and ensure that no objects filled with liquids, such as vases, are placed on the equipment.
16. To completely disconnect this equipment from the a.c. mains, disconnect the power supply cord plug from the a.c. receptacle.
17. The mains plug of the power supply cord shall remain readily operable.
18. Do not expose batteries to excessive heat such as sunshine, fire or the like.

---

## Thank You

Your decision to own this McIntosh MPC1500 Power Controller ranks you at the very top among discriminating music listeners. You now have “The Best.” The McIntosh dedication to “Quality,” is assurance that you will receive many years of enjoyment from this component. Please take a short time to read the information in this manual. We want you to be as familiar as possible with all the features and functions of your new McIntosh.

---

## Please Take A Moment

The serial number, purchase date and McIntosh Dealer name are important to you for possible insurance claim or future service. The spaces below have been provided for you to record that information:

Serial Number: \_\_\_\_\_

Purchase Date: \_\_\_\_\_

Dealer Name: \_\_\_\_\_

---

## Technical Assistance

If at any time you have questions about your McIntosh product, contact your McIntosh Dealer who is familiar with your McIntosh equipment and any other brands that may be part of your system. If you or your Dealer wish additional help concerning a suspected problem, you can receive technical assistance for all McIntosh products at:

McIntosh Laboratory, Inc.  
2 Chambers Street  
Binghamton, New York 13903  
Phone: 607-723-1545  
Fax: 607-724-0549

---

## Customer Service

If it is determined that your McIntosh product is in need of repair, you can return it to your Dealer. You can also return it to the McIntosh Laboratory Service Department. For assistance on factory repair return procedure, contact the McIntosh Service Department at:

McIntosh Laboratory, Inc.  
2 Chambers Street  
Binghamton, New York 13903  
Phone: 607-723-3515  
Fax: 607-723-1917

Copyright 2008 © by McIntosh Laboratory, Inc.

---

## Table of Contents

Safety Instructions .....	2
Thank You and Please Take a Moment.....	3
Technical Assistance and Customer Service .....	3
Table of Contents .....	3
General Information .....	3
Connector and Cable Information .....	4
Introduction.....	4
Performance Features .....	4
Dimensions .....	5
Installation .....	6
Rear Panel Connections.....	7
How to Connect in a Two Channel System .....	8
How to Connect in a Multi Channel System .....	9
Front Panel Displays and Controls.....	10
How to Operate the MPC1500.....	11
Specifications.....	14
Packing Instructions .....	15

---

## General Information

1. For additional connection information, refer to the owner’s manual(s) for any component(s) connected to the MPC1500 Power Controller.
2. The Main AC Power going to the MPC1500 and any other McIntosh Component(s) should not be applied until all the system components are connected together. Failure to do so could result in malfunctioning of some or all of the system’s normal operations.
3. In the event the MPC1500 Power Controller overheats due to improper ventilation and/or high ambient temperature, the Power Controller will switch off. When the MPC1500 has returned to a safe operating temperature, normal operation will resume.
4. The MPC1500 is designed for connection of Audio/ Video Components with low energy consumption. This would include components such as Preamplifiers, A/V Control Centers, Source Components, Integrated Amplifiers and Power Amplifiers with low to modest power output.

The total amount of current drawn by all the components connected to the MPC1500 should not exceed 11.2 Amps. Typically, components consuming low amounts of energy are rated in watts. To calculate the total energy consumed, it is usually easier to convert components rated in Watts to a current rating and then add up the total current consumed. To convert a wattage rating into an approximate current rating take the watts rating and divide it by 100. For example, if a component has a rating of 65 watts divide it by 100, this would provide an approximate rating of 0.65 Amps.



## Connector and Cable Information

### Power Control Connector

The MPC1500 Global Power Control Input and Local Power Control Inputs receive On/Off signals from +5 to +12 volts. The Global Power Control Output will provide a +12 volt Output Signal with a current up to 20mA. The Local Power Control Outputs will in turn provide from +5 to +12 volt Output Signal (Input Signal Dependent). The Global Power Control Input has an additional connection for controlling the illumination of the MPC1500 Voltage and Current Output Meters. The 1/8 inch stereo mini phone plug connects to a Pre-amplifier or an A/V Control Center Power Control Output.

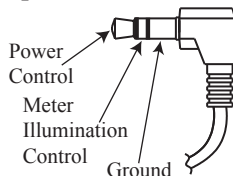

*Note: The Power Control Connecting Cable is available from the McIntosh Parts Department:*

**Data and Power Control Cable Part No. 170-202**

*Six foot, shielded 2 conductor, with 1/8 inch stereo mini phone plugs on each end.*

## Introduction

Now you can add to your system the advantage of traditional McIntosh standards of excellence in the MPC1500 Power Controller. It offers full transformer isolation from the incoming AC Line for the components connected to it. The MPC1500 helps to assure the sound and video reproduction from your McIntosh System is the best it can be, totally transparent and absolutely accurate.

## Performance Features

### • Toroidal Isolation Power Transformer

The very large Toroidal Isolation Power Transformer used in the MPC1500 occupies over three quarters of the internal space in the chassis. It ensures stable noise free operation for the audio/video components connected to the MPC1500. It also isolates them from potential interference produced from common household appliances that utilize motors, compressors and electronic control devices.

### • Stable Voltage

The MPC1500's Large Isolation Power Transformer minimizes variations in the voltage available to the connected components as they draw more current, up to the 11.2 Amp rating.

### • Lono Technology

The LONO™ (Low Noise) Transformer Technology from Plitron used in the MPC1500, eliminates audible noise

LONO™ - is a registered trademark of Plitron Manufacturing Inc.

emanating from the Transformer and thus will not distract from musical enjoyment, even with varying AC Line conditions.

### • Superior Line Surge Protection

The McIntosh MPC1500 utilizes the finest, most sophisticated surge suppression technology available. Unlike most of the AC Line Surge protection devices available, the MPC1500 doesn't rely on commonly used inexpensive MOV devices. The MOV's can fail after just one surge thus no longer providing protection and they can allow as much as 300 volts through to the connected components allowing substantial damage to occur. The MPC1500 incorporates Torus™ Surge Suppression Circuitry, which activates around 2V above peak nominal voltage providing constant long term protection.

### • Illuminated Voltage and Current Meters

The Illuminated Voltage and Current Meters indicate at all times the voltage available to your McIntosh Components and the actual current consumed by them.

### • Power Control

The Power Control Input connection provides convenient Turn-On/Off of the McIntosh MPC1500 with your McIntosh System.

### • Extruded Side Panels

The sides of the MPC1500 are extruded aluminum panels with a bead blast textured surface and a black anodized finish.

### • Fiber Optic Solid State Front Panel Illumination

The even Illumination of the Front Panel is accomplished by the combination of custom designed Fiber Optic Light Diffusers and extra long life Light Emitting Diodes (LEDs). The glass Front Panel ensures the pristine beauty of the MPC1500 will be retained for many years.

Torus™ - Torus Power Technology under license from Plitron Manufacturing Inc.

**Dimensions**

The following dimensions can assist in determining the best location for your MPC1500. There is additional information on the next page pertaining to installing the MPC1500 into cabinets.

**Front View of the MPC1500**

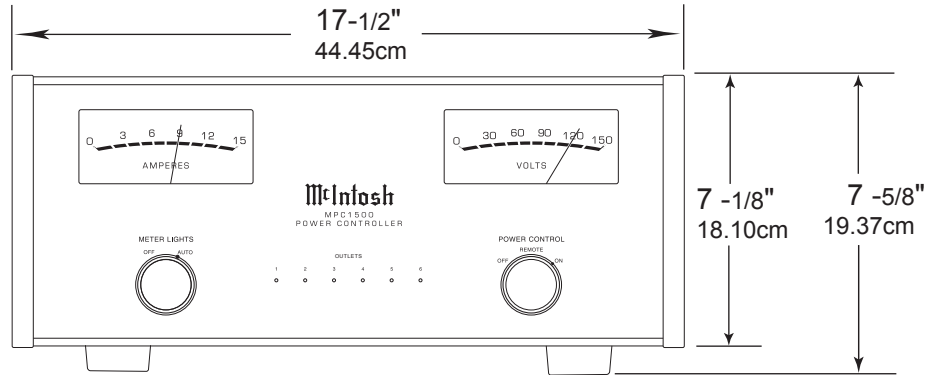

**Rear View of the MPC1500**

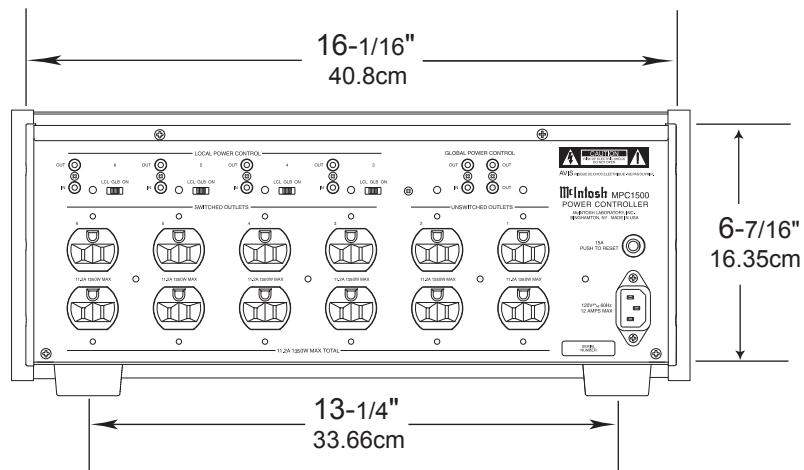

**Side View of the MPC1500**

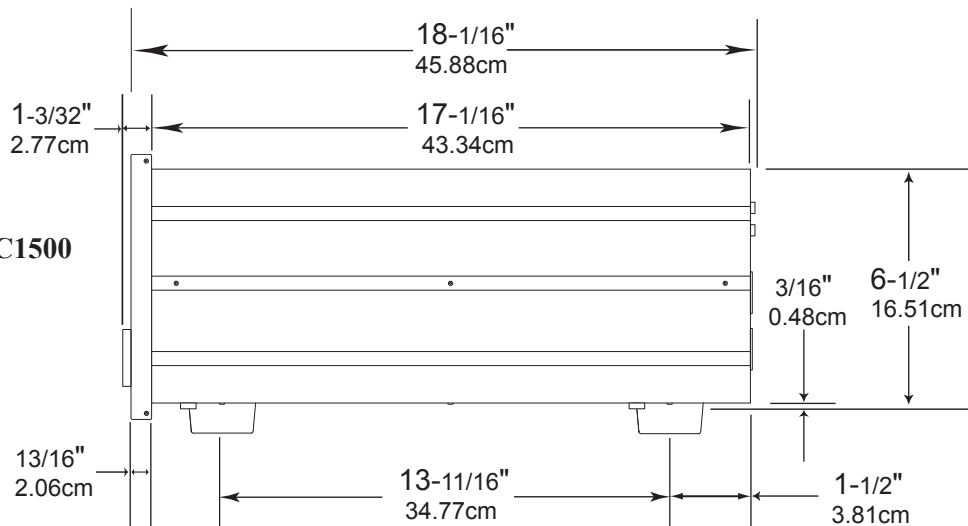

### Installation

The MPC1500 can be placed upright on a table or shelf, standing on its four feet. It also can be custom installed in a piece of furniture or cabinet of your choice. The four feet may be removed from the bottom of the MPC1500 when it is custom installed as outlined below. The four feet together with the mounting screws should be retained for possible future use if the MPC1500 is removed from the custom installation and used free standing. The required panel cutout, ventilation cutout and unit dimensions are shown. Always provide adequate ventilation for your MPC1500.

Cool operation ensures the longest possible operating life for any electronic instrument. Do not install the MPC1500 directly above a heat generating component such as a high powered amplifier. If all the components are installed in a single cabinet, a quiet running ventilation fan can be a definite asset in maintaining all the system components at the coolest possible operating temperature.

A custom cabinet installation should provide the following minimum spacing dimensions for cool operation. Allow at least 4 inches (10.16cm) above the top, 2 inches (5.08cm)

below the bottom and 1 inch (2.54cm) on each side of the Power Controller, so that airflow is not obstructed. Allow 20 inches (50.8cm) depth behind the front panel. Allow 2 inches (5.08cm) in front of the mounting panel for knobs. Be sure to cut out a ventilation hole in the mounting shelf according to the dimensions in the drawing.

**MPC1500 Front Panel Custom Cabinet Cutout**

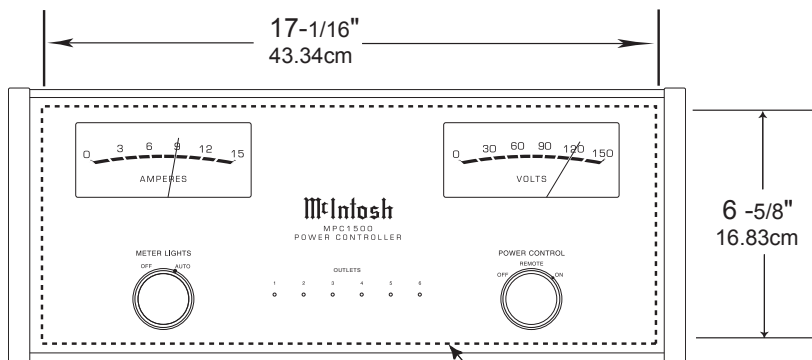

**MPC1500 Side View in Custom Cabinet**

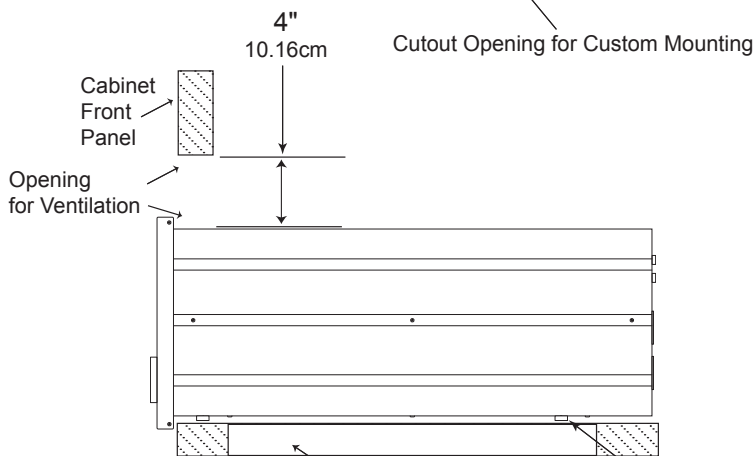

**MPC1500 Bottom View in Custom Cabinet**

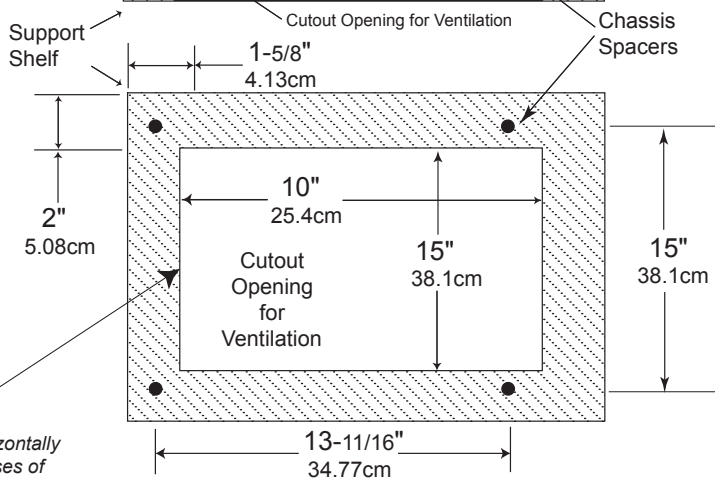

*Note: Center the cutout Horizontally on the unit. For purposes of clarity, the above illustration is not drawn to scale.*



# Rear Panel Connections

LOCAL POWER CONTROL for AC Outlet number 6 receives a turn-on signal (5 to 12 volts) from a component and the LOCAL POWER CONTROL OUT sends a turn-on signal (same voltage as the Power Control Input) on to another component. The LED indicates when the AC Outlet is active. The LOCAL POWER CONTROL switch selects LOCAL, GLOBAL or always ON activation

LOCAL POWER CONTROL for AC Outlet number 5 receives a turn-on signal (5 to 12 volts) from a component and the LOCAL POWER CONTROL OUT sends a turn-on signal (same voltage as the Power Control Input) onto another component. The LED indicates when the AC Outlet is active. The LOCAL POWER CONTROL switch selects LOCAL, GLOBAL or always ON activation

LOCAL POWER CONTROL for AC Outlet number 4 receives a turn-on signal (5 to 12 volts) from a component and the LOCAL POWER CONTROL OUT sends a turn-on signal (same voltage as the Power Control Input) onto another component. The LED indicates when the AC Outlet is active. The LOCAL POWER CONTROL switch selects LOCAL, GLOBAL or always ON activation

LOCAL POWER CONTROL for AC Outlet number 3 receives a turn-on signal (5 to 12 volts) from a component and the LOCAL POWER CONTROL OUT sends a turn-on signal (same voltage as the Power Control Input) onto another component. The LED indicates when the AC Outlet is active. The LOCAL POWER CONTROL switch selects LOCAL, GLOBAL or always ON activation

GLOBAL POWER CONTROL IN receives a turn-on signal (5 to 12 volts) for the Local Power Control selection of Global and the GLOBAL POWER CONTROL OUT sends a delayed turn-on signal (12 volts) to other Component(s)

The LEDs indicate the MPC1500 Power Controller is connected to a live AC Outlet and the UNSWITCHED AC OUTLETS number 1 and 2 are active.

CIRCUIT BREAKER press to reset if the MPC1500 Power Controller will not power up

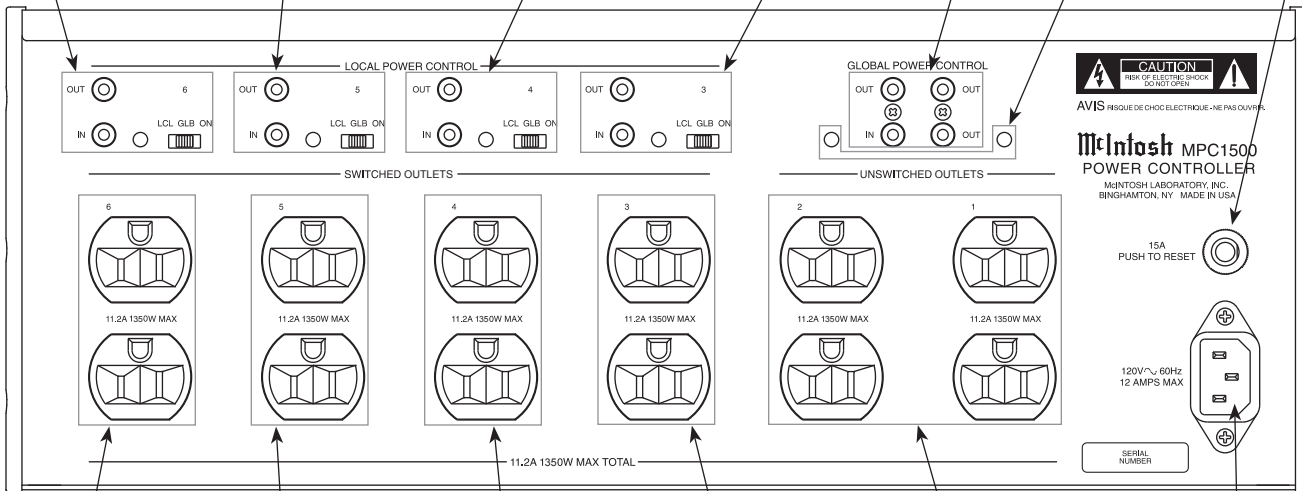

SWITCHED AC Outlet controlled by LOCAL POWER CONTROL number 6 Switch Setting and/or the received Power Control Signal

SWITCHED AC Outlet controlled by LOCAL POWER CONTROL number 5 Switch Setting and/or the received Power Control Signal

SWITCHED AC Outlet controlled by LOCAL POWER CONTROL number 4 Switch Setting and/or the received Power Control Signal

SWITCHED AC Outlet controlled by LOCAL POWER CONTROL number 3 Switch Setting and/or the received Power Control Signal

Unswitched AC outlets number 1 and 2 are active when the MPC1500 is connected to a live AC Outlet

Connect the MPC1500 power cord to a live AC outlet. Refer to information on the back panel of your MPC1500 to determine the correct voltage for your unit



## How to Connect in a Two Channel System

The MPC1500 has the ability to automatically switch AC Power On/Off to Components connected to the SWITCHED AC OUTLETS via the Power Control connection coming from the Preamplifier. Source Components switch On/Off via the Power Control connection from the Preamplifier. For additional information refer to "General Information" on page 3 and "Connector and Cable Information" on page 4.

1. Connect a Control Cable from the MPC1500 GLOBAL POWER CONTROL IN Jack to the Power Control Main Out Jack on the Preamplifier.
2. Connect the AC Power Cord from the Power Amplifier to MPC1500 SWITCHED AC OUTLET 3.
3. Connect a Control Cable from the Preamplifier Acc Power Control Out Jack to the Power Control In jack on the Disc Player.

4. Connect the AC Power Cords from the Preamplifier and Disc Player to the UNSWITCHED AC OUTLETS 1 and 2.
5. Connect any remaining Components in a similar manner.
6. Using the supplied AC Cord, connect the MPC1500 directly to an AC Wall Outlet.

Power Amplifier

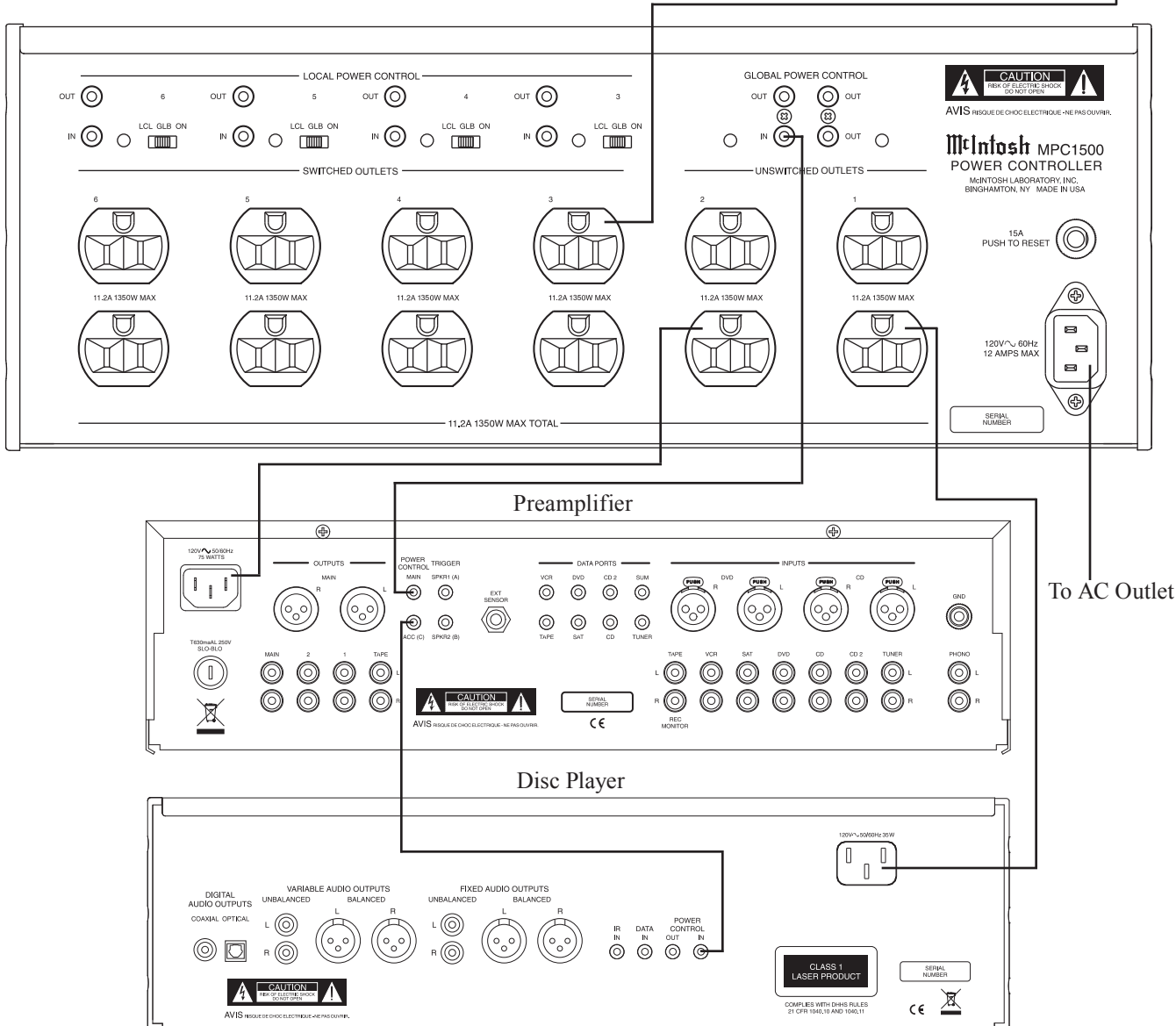
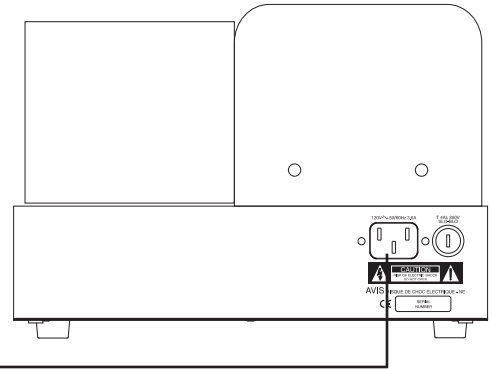

To AC Outlet



## How to Connect in a Multi Channel System

In the following example two of the four SWITCHED AC OUTLETS on the MPC1500 will operate differently from the default settings. For additional information refer to "How to Operate" on page 11.

1. Connect a Control Cable from the MPC1500 LOCAL POWER CONTROL IN Jack number 4 to the Power Control Zone B Out Jack on the A/V Control Center. Place the number 4 switch in the LCL position.
2. Connect the AC Power Cord from the Power Amplifier to MPC1500 SWITCHED AC OUTLET 4.
3. Connect a Control Cable from the MPC1500 GLOBAL POWER CONTROL IN Jack to A/V Control Center

ACC Power Control Out Jack.

4. Connect a Control Cable from the MPC1500 GLOBAL POWER CONTROL OUT Jack to the Power Control In jack on the Disc Player.
5. Connect the AC Power Cords from the Disc Player to the SWITCHED AC OUTLET 6. Place the number 6 switch in the ON position.
6. Connect any remaining Components in a similar manner.
7. Using the supplied AC Cord, connect the MPC1500 directly to an AC Wall Outlet.

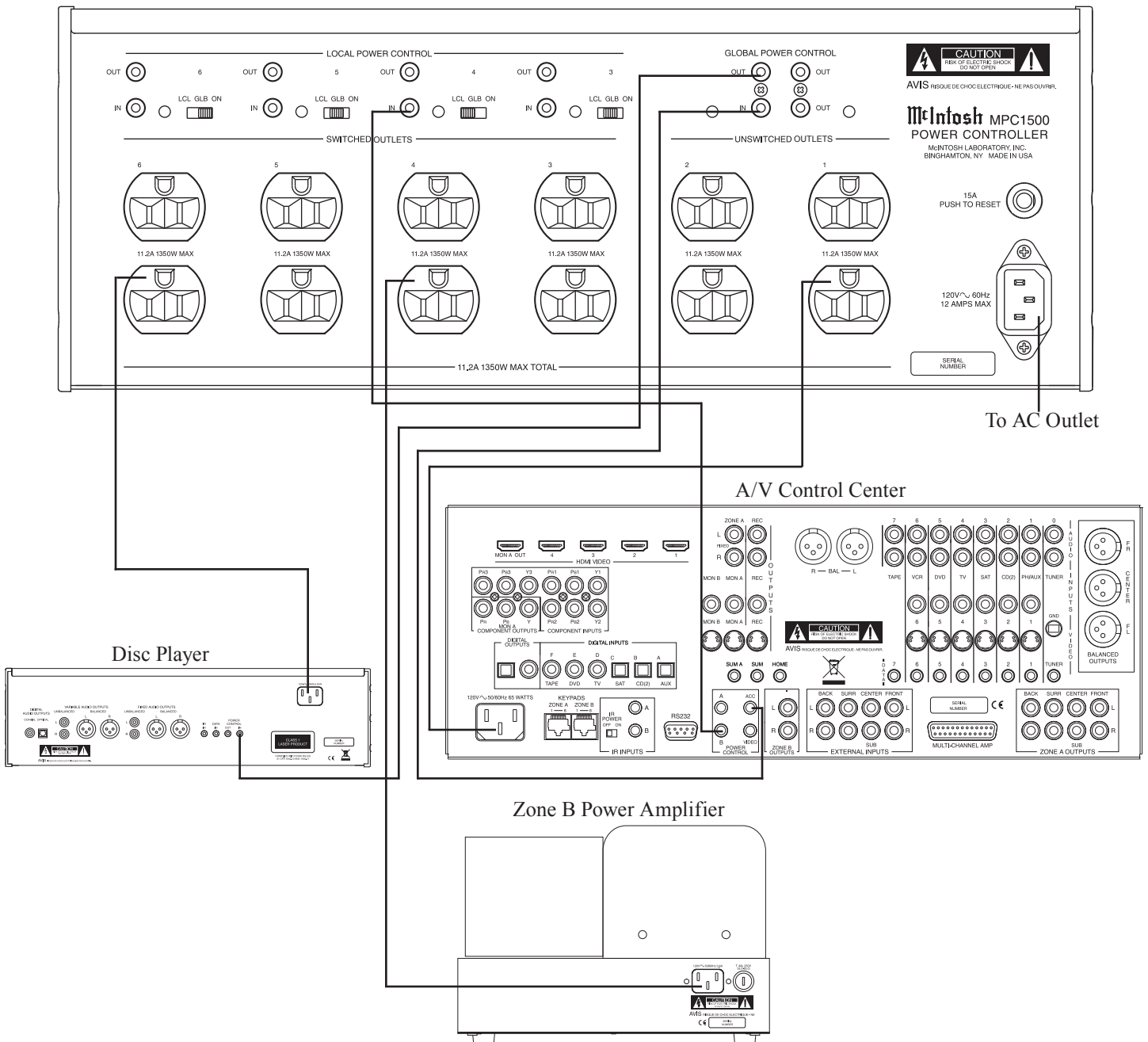



Meter indicates the total current consumed by the components connected to the MPC1500

Meter indicates the outgoing AC Line Voltage

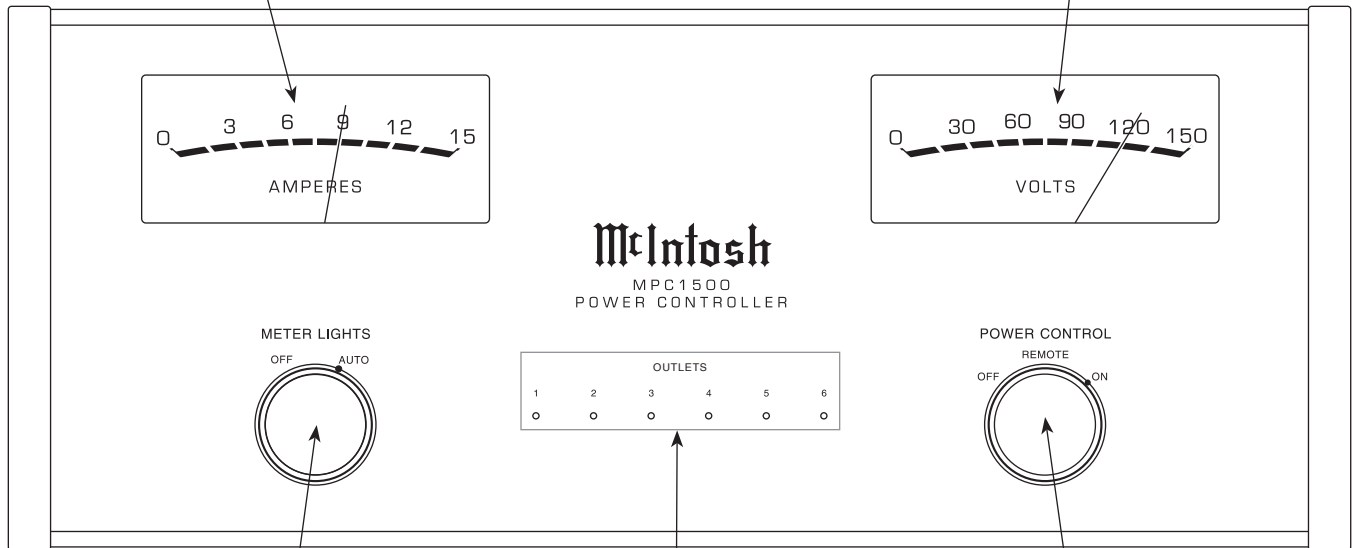

METER LIGHTS Switch selects Meter Illumination Off or Auto Mode

OUTLETS LEDs indicate the active AC Outlet(s)

POWER CONTROL Switch Turns AC Power Off, Remote or On

## How to Operate

The MPC1500 Power Controller is very versatile in its connection and operation in an Audio, Video or Audio/Video System. There are two examples of connecting and using the MPC1500 on pages 8 and 9 of this Owner's Manual. By becoming familiar with the "How to Operate" section of this Owner's Manual many additional connection and operation possibilities will become apparent.

### Power Control

To have the MPC1500 automatically turn On or Off when a Preamplifier or A/V Control Center turns on or off, rotate the POWER CONTROL Switch to the REMOTE position. For manual operation, rotate the POWER CONTROL Switch to the ON or OFF position as desired. Refer to figure 1.

*Notes: 1. There must be a power control connection between the MPC1500 Global Power Control Input and the Preamplifier or A/V Control Center, in order for the remote power turn-on to function.*

- 2. When the POWER CONTROL Switch is placed in the ON the position, the Global Power Control Input activation is overridden.*
- 3. AC Outlets 3 thru 6 switch On in sequence with a slight delay in time between each outlet activation.*

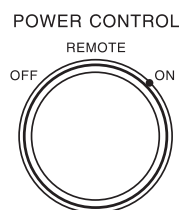

Figure 1

### Meter Illumination

Rotate the METER LIGHTS Switch to select the meter operation mode you desire. Refer to figure 2.

OFF - Meter lights are switched Off.

*Note: The meters will continue to indicate the Input AC Line Voltage and the consumed Current.*

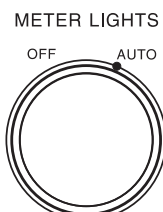

Figure 2

AUTO - Meter lights are switched

On. When Global Power Control Input of the MPC1500 is connected to a McIntosh Preamplifier or A/V Control Center with Remote Meter Illumination Control, the Meter Illumination will be remotely controlled (On/Off).

### Volt Meter

The VOLTS Meter indicates the AC Voltage available at the AC Outlets on the MPC1500 Rear Panel. Refer to figure 3. The MPC1500 utilizes a very large isolation power transformer, so essentially the VOLTS Meter reading is a reflection of the incoming AC Line Voltage. If the VOLTS

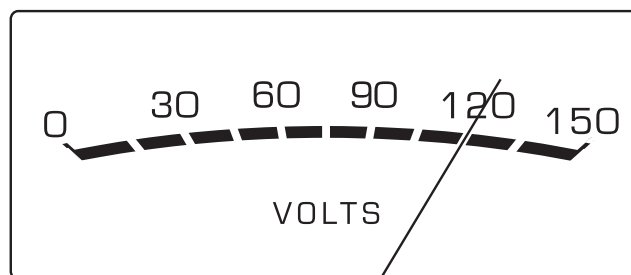

Figure 3

Meter reading starts to drop more than several volts (from the nominal voltage reading at lower current consumption) when the MPC1500 AMPERES Meter indicates 6 Amps of current or greater, it may be an indication of a condition known as "AC Line Sag". AC Line Sag is usually a result of limitations in the AC Wiring in the walls due to small wire size and/or long lengths of wire. For additional assistance in this matter contact your McIntosh Dealer and/or Electrical Contractor.

### Current Meter

The AMPERES Meter indicates the total amount of current being consumed by the components connected to the MPC1500 AC Outlets. Refer to figure 4. It is normal for the AMPERES Meter indication to fluctuate especially when a Power Amplifier or Integrated Amplifier is connected to the MPC1500 AC Outlets and music is being played loudly.

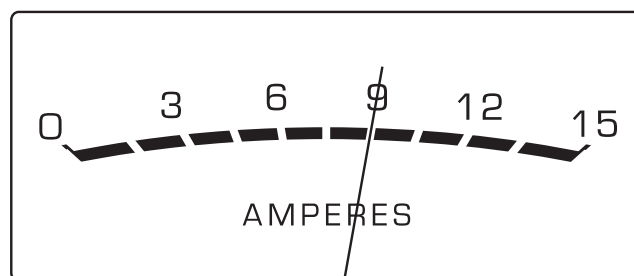

Figure 4

### Rear Panel Options

AC Outlets number 3 thru 6 can be individually configured to become active via three different methods using the Rear Panel Switches. The first way is using the default configuration (the switch in the GLB position) where the outlet is controlled to switch On or Off via the MPC1500 Global Power Control Input or the Front Panel Power Control Switch. Refer to figure 5 on the next page. The second option is to have any one of the AC Outlets (number 3 thru 6) controlled independently On/Off via the MPC1500 Local Power Control Input for each outlet by placing the

## How to Operate, con't

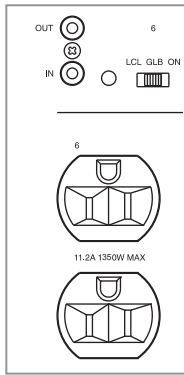

Figure 5

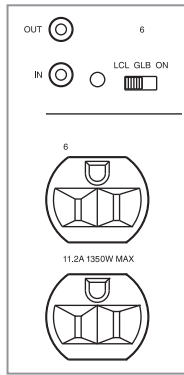

Figure 6

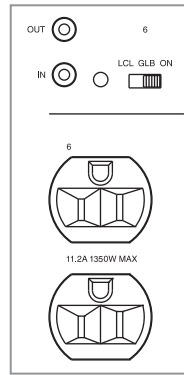
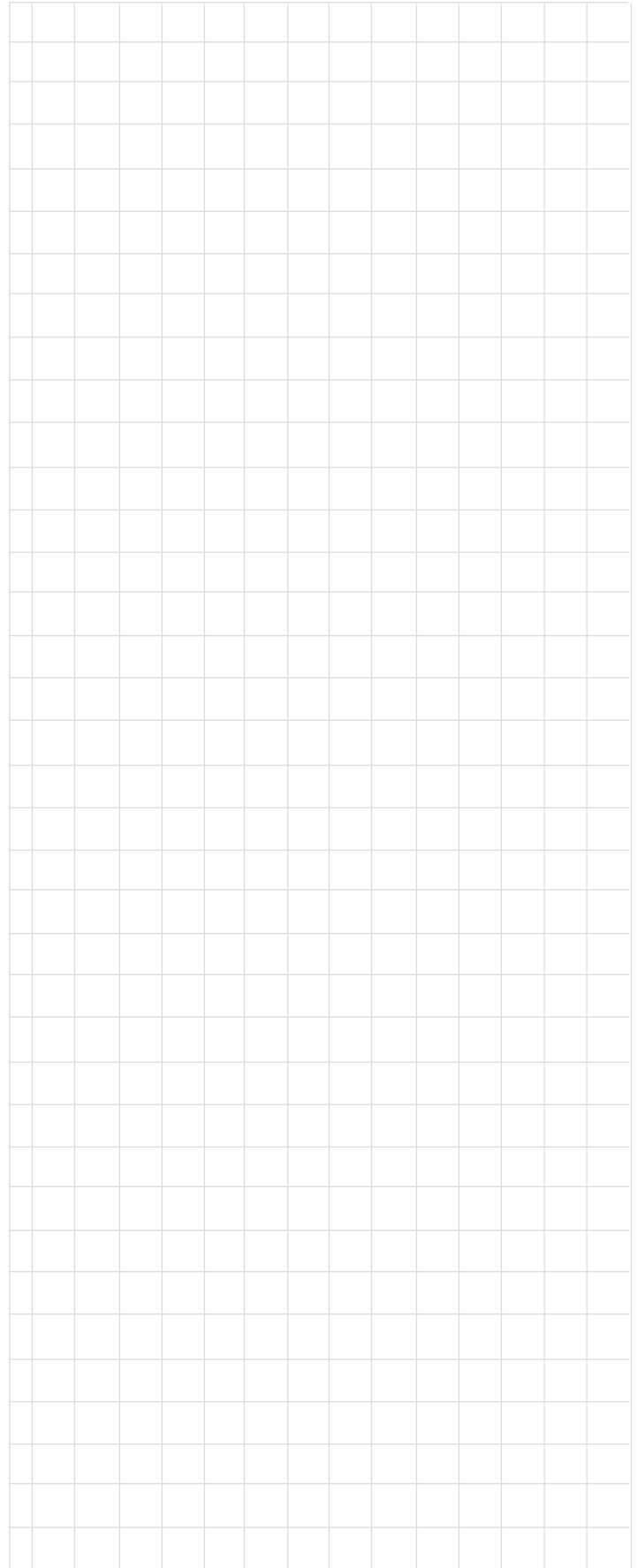
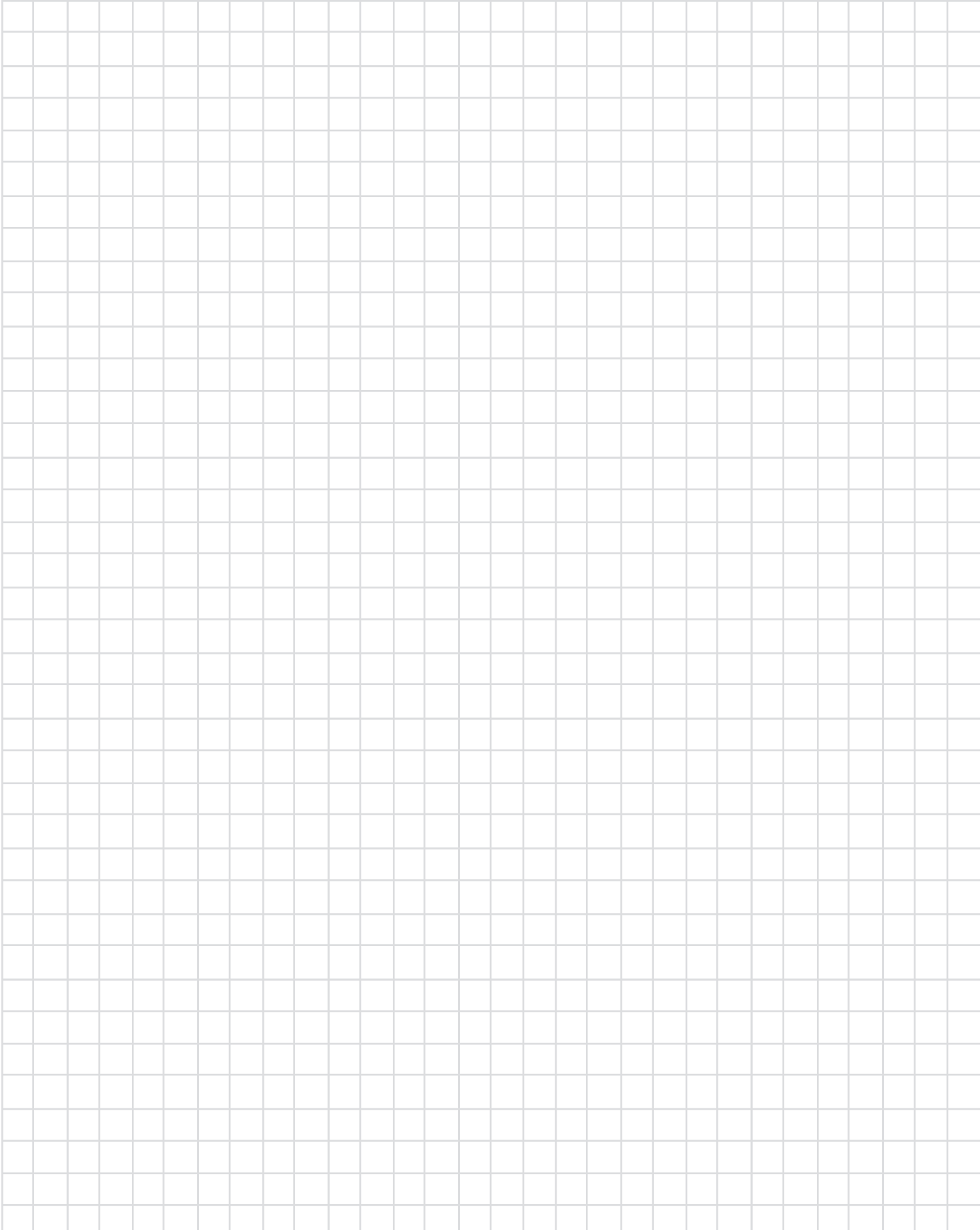

Figure 7

Rear Panel Switch in the LCL Position. Refer to figure 6.  
The last option is to have the AC Outlets number 3 thru 6  
On all the time by placing the Rear Panel Switch in the ON  
Position. Refer to figure 7.







## Specifications

---

### Output Voltage

120 Volts AC Nominal

### Load Regulation

± 2.5 %

### Power Requirement

120 Volts, 60Hz

12.0 Amps, maximum current

1440 Watts, maximum power

### Overall Dimensions

Width is 17-1/2 inches (44.45cm)

Height is 7-5/8 inches (19.37cm) including feet

Depth is 22 inches (55.88cm) including the Front Panel,  
Knobs and Cables

### Weight

87 pounds (39.46 kg) net, 105 pounds (47.63 kg) in shipping  
carton

### Shipping Carton Dimensions

Width is 29-1/2 inches (74.93cm)

Depth is 29 inches (73.66cm)

Height is 17 inches (43.18cm)



## Packing Instructions

In the event it is necessary to repack the equipment for shipment, the equipment must be packed exactly as shown below. It is very important that the four plastic feet are attached to the bottom of the equipment. Two #10 x 2-1/2 inch screws and washers must be used to fasten the unit securely to the bottom pad and wood skid. This will ensure the proper equipment location on the bottom pad. Failure to do this will result in shipping damage.

Use the original shipping carton and interior parts only if they are all in good serviceable condition. If a shipping carton or any of the interior part(s) are needed, please call or write Customer Service Department of McIntosh Laboratory. Refer to page 3. Please see the Part List for the correct part numbers.

Quantity	Part Number	Description
1	033888	Shipping carton
4	033887	End Cap
1	033697	Inner carton
1	033725	Top pad
1	034301	Bottom pad
1	033699	Wood skid
2	017218	Plastic foot (spacer)
2	401204	#10 x 2-1/2 inch wood screw
2	404033	#10 flat washer 1-3/4 inch
4	017937	Plastic foot
4	400159	#10-32 x 3/4 machine screw
4	404080	#10 flat washer

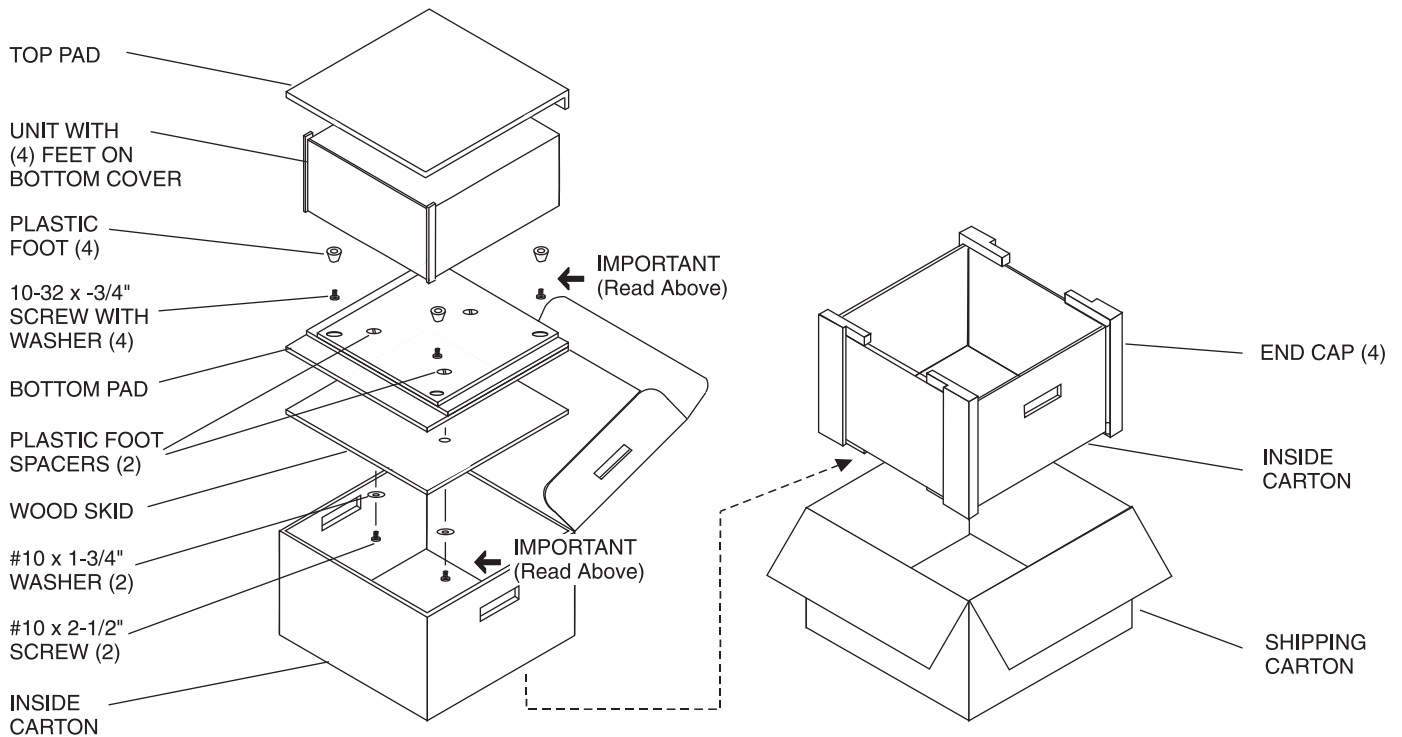



McIntosh Laboratory, Inc.  
2 Chambers Street  
Binghamton, NY 13903

The continuous improvement of its products is the policy of McIntosh Laboratory Incorporated who reserve the right to improve design without notice. Printed in the U.S.A.