



McIntosh Laboratory, Inc. 2 Chambers Street Binghamton, New York 13903-2699 Phone: 607-723-3512 [www.mcintoshlabs.com](http://www.mcintoshlabs.com)

MT10  
Precision Turntable  
Owner's Manual



The lightning flash with arrowhead, within an equilateral triangle, is intended to alert the user to the presence of uninsulated “dangerous voltage” within the product’s enclosure that may be of sufficient magnitude to constitute a risk of electric shock to persons.

**WARNING - TO REDUCE RISK OF FIRE OR ELECTRICAL SHOCK, DO NOT EXPOSE THIS EQUIPMENT TO RAIN OR MOISTURE.**

## IMPORTANT SAFETY INSTRUCTIONS!

### PLEASE READ THEM BEFORE OPERATING THIS EQUIPMENT.

1. Read these instructions.
2. Keep these instructions.
3. Heed all warnings.
4. Follow all instructions.
5. Do not use this apparatus near water.
6. Clean only with a dry cloth.
7. Do not block any ventilation openings. Install in accordance with the manufacturer’s instructions.
8. Do not install near any heat sources such as radiators, heat registers, stoves, or other apparatus (including amplifiers) that produce heat.
9. Do not defeat the safety purpose of the polarized or grounding-type plug. A polarized plug has two blades with one wider than the other. A grounding type plug has two blades and a third grounding prong. The wide blade or the



**AVIS** RISQUE DE CHOC ELECTRIQUE - NE PAS OUVRIR.  
**NO USER-SERVICEABLE PARTS INSIDE. REFER SERVICING TO QUALIFIED PERSONNEL.**

third prong are provided for your safety. If the provided plug does not fit into your outlet, consult an electrician for replacement of the obsolete outlet.

10. Protect the power cord from being walked on or pinched particularly at plugs, convenience receptacles, and the point where they exit from the apparatus.
11. Only use attachments/accessories specified by the manufacturer.
12. Use only with the cart, stand, tripod, bracket, or table specified by the manufacturer, or sold with the apparatus. When a cart is used, use caution when moving the cart/apparatus combination to avoid injury from tip-over.
13. Unplug this apparatus during lightning storms or when unused for long periods of time.
14. Refer all servicing to qualified service personnel. Servicing is required when the apparatus has been damaged in any way, such as power-supply cord or plug is damaged, liquid has been spilled or objects have fallen into the apparatus, the apparatus has been exposed to



The exclamation point within an equilateral triangle is intended to alert the user to the presence of important operating and maintenance (servicing) instructions in the literature accompanying the appliance.

**To prevent the risk of electric shock, do not remove cover or back. No user-serviceable parts inside.**

**WARNING: Use this product only with the Power Adapter provided. Failure to do so may result in fire and/or electrical shock.**

- rain or moisture, does not operate normally, or has been dropped.
15. Do not expose this equipment to dripping or splashing and ensure that no objects filled with liquids, such as vases, are placed on the equipment.
16. To completely disconnect this equipment from the a.c. mains, disconnect the AC / DC Adapter from the a.c. receptacle.
17. The mains plug of the power supply cord shall remain readily operable. If the AC / DC Adapter is provided with a mains power supply cord attachment, the plug of this power supply cord shall remain readily operable.
18. Do not expose batteries to excessive heat such as sunshine, fire or the like.
19. Connect mains power supply cord only to a mains socket outlet with a protective earthing connection.

---

## Thank You

Your decision to own this McIntosh MT10 Precision Turntable and MCC10 Moving Coil Cartridge ranks you at the very top among discriminating music listeners. You now have “The Best.” The McIntosh dedication to “Quality,” is assurance that you will receive many years of musical enjoyment from this unit. Please take a short time to read the information in this manual. We want you to be as familiar as possible with all the features and functions of your new McIntosh.

## Please Take A Moment

The serial number, purchase date and McIntosh Dealer name are important to you for possible insurance claim or future service. The spaces below have been provided for you to record the Turntable and Cartridge information:

Dealer Name	Purchase Date	Model Number	Serial Number
		MT10	
		MCC10	

## Technical Assistance

If at any time you have questions about your McIntosh product, contact your McIntosh Dealer who is familiar with your McIntosh equipment and any other brands that may be part of your system. If you or your Dealer wish additional help concerning a suspected problem, you can receive technical assistance for all McIntosh products at:

McIntosh Laboratory, Inc.  
2 Chambers Street  
Binghamton, New York 13903  
Phone: 607-723-1545  
Fax: 607-724-0549

## Customer Service

If it is determined that your McIntosh product is in need of repair, you can return it to your Dealer. You can also return it to the McIntosh Laboratory Service Department. For assistance on factory repair return procedure, contact the McIntosh Service Department at:



McIntosh Laboratory, Inc.  
2 Chambers Street  
Binghamton, New York 13903  
Phone: 607-723-3515  
Fax: 607-723-1917

## Table of Contents

Safety Instructions .....	2
Thank You and Please Take a Moment.....	3
Technical Assistance and Customer Service .....	3
Table of Contents .....	3
General Information .....	4
Connector and Cable Information .....	4
Introduction.....	5
Performance Features .....	5
Dimensions .....	6
Unpacking the Turntable.....	7
Assembling the Turntable .....	8
Installing a non-supplied Cartridge and Tone Arm Adjustments .....	10
Rear Panel Connections and Adjustments .....	13
How to Connect the Turntable .....	14
Front Panel Display, Switches, Lever and Record Clamp.....	16
How to Operate the Turntable.....	17
Specifications.....	18
Packing Instruction.....	19

## General Information

**Caution:** To prevent possible damage to the turntable platter bearing, do not move the MT10 Precision Turntable with the platter installed.

- For additional connection information, refer to the owner's manual(s) for any component(s) connected to the MT10 Precision Turntable.
- The MT10 Precision Turntable comes with the McIntosh MCC10 High Performance Moving Coil Cartridge.
- It is recommended the Professionals at your McIntosh Dealer, who are skilled in all aspects of Turntables and Phono Cartridges, install the MT10 Precision Turntable and any associated audio equipment.
- For optimum performance, the setup and adjustment of the MT10 Precision Turntable requires special test recordings and test/measurement equipment. Contact your McIntosh Dealer for additional information and assistance.
- When discarding the unit, comply with local rules or regulations. Batteries should never be thrown away or incinerated but disposed of in accordance with the local regulations concerning battery disposal. 
- For additional information on the MT10 and other McIntosh Products please visit the McIntosh Web Site at [www.mcintosh-labs.com](http://www.mcintosh-labs.com). 
- When an AC Line Cord is used to connect the supplied AC / DC Adapter to an AC Outlet, it is important the line cord conductor size is a minimum is 0.75mm<sup>2</sup> for each leg of the two conductor cord.

- If it should become necessary to replace the supplied AC / DC Adapter and/or the plug adapters, order part number 320310SP from the McIntosh Parts Department. Refer to the illustration below.



## Connector and Cable Information

### Power Control Connector

The MT10 Power Control Input/Output Jacks receive/send Power On/Off Signals when connected to other McIntosh Components. A 1/8 inch stereo mini phone plug is used for connection to the Power Control Input/Output on the MT10.

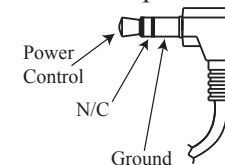

*Note:* The Data and Power Control Connecting Cable is available from the McIntosh Parts Department:

**Data and Power Control Cable Part No. 170-202**  
Six foot, shielded 2 conductor, with 1/8 inch stereo mini phone plugs on each end.

### Tonearm Headshell Wiring

Refer to the following list of wire colors in the headshell for installing the cartridge into the Headshell:

<u>Cartridge Connections</u>	<u>Headshell Wire Color</u>
Left Channel (+)	White
Left Channel (-)	Blue
Right Channel (+)	Red
Right Channel (-)	Green

### McIntosh MCC10 Cartridge Connections

Refer to the following illustration when connecting the McIntosh Cartridge in the Headshell:

#### Rear View of McIntosh MCC10 Cartridge

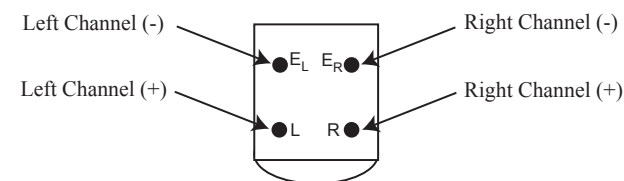

### Introduction

The McIntosh MT10 Precision Turntable with the McIntosh MCC10 Moving Coil Cartridge offers the latest in playback of vinyl recordings. A full complement of performance features allows for the enjoyment of all recordings reproduced with flawless realism. The advanced electronic and mechanical design ensures many years of smooth trouble free operation.

### Performance Features

#### • **Advanced Technology Turntable**

The MT10 combines the latest technology in Phono Cartridges, Tone Arms, Mechanical Suspensions and Record Platter Rotation for superb performance and accurate operation.

#### • **Moving Coil Cartridge**

The McIntosh MCC10 Moving Coil Cartridge has a hand polished ebony wood-tone body and is slightly rounded, leading to a resonance free construction. High impedance, together with high output voltage, ensures noise free musical reproduction. The ruler-flat frequency response from 20Hz to 20kHz provides solid realistic bass, uncolored midrange and natural high frequencies.

#### • **Tone Arm**

The MT10 Tone Arm is made from Dural-Aluminum with special damping material. The Tone Arm is both light in weight and highly rigid. The noise free Vertical Bearings are made from two high precision ceramic surfaces with damping fluid. The Horizontal Bearing is a gimballed sapphire design.

#### • **Turntable Platter**

The over twelve pound, two and one-half inch thick platter is made from a special silicone acrylic material. This helps to resist external vibrations from reaching the record during playback and its large mass provides the perfect flywheel action for stable playback speed.

#### • **Precision Motor and Drive Electronics**

The Swiss made DC Brushless Motor is controlled by a highly refined servo control system. As the Turntable Platter rotates, an optical sensor “reads” the 1595 micro stripes on a disk affixed to the bottom of the platter. This provides precise feedback information to the servo control system thus assuring very accurate speed rotation.

#### • **Illuminated Speed Meter**

The Illuminated Speed Meter on the MT10 indicates the true rotation speed of the turntable platter.

#### • **Magnetic Air Dampened Bearing**

The MT10 Turntable Platter rotates on a special bearing using magnetic suspension together with a cushion of air to provide vibration free rotation.

#### • **Multi-Layered Dampened Chassis**

The MT10 Turntable Chassis is composed from a Stainless Steel base plate, a thick Aluminum plate, an Acrylic plate and together with internal dampening material all help to assure the only sound heard is from the record groove itself.

#### • **Power Control**

The Power Control Input connection provides convenient Turn-On/Off of the MT10 Front Panel Illumination when connected to a McIntosh System with Power Control.

#### • **Fiber Optic Solid State Illumination**

The even Illumination of the Front Panel and the Turntable Platter is accomplished by the combination of custom designed Fiber Optic Light Diffusers and extra long life Light Emitting Diodes (LEDs).

#### • **Glass Front Panel and Super Mirror Chassis Finish**

The famous McIntosh Illuminated Glass Front Panel and the Stainless Steel Chassis with Super Mirror Finish ensure the pristine beauty of the MT10 will be retained for many years.

**Dimensions**

The following dimensions can assist in determining the best location for your MT10.

**Front View of the MT10**

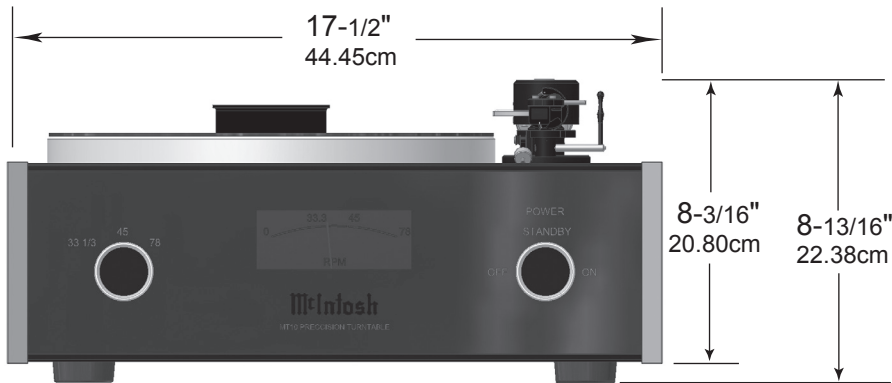

*Note: The height measurements are with the McIntosh Cartridge installed.*

**Rear View of the MT10**

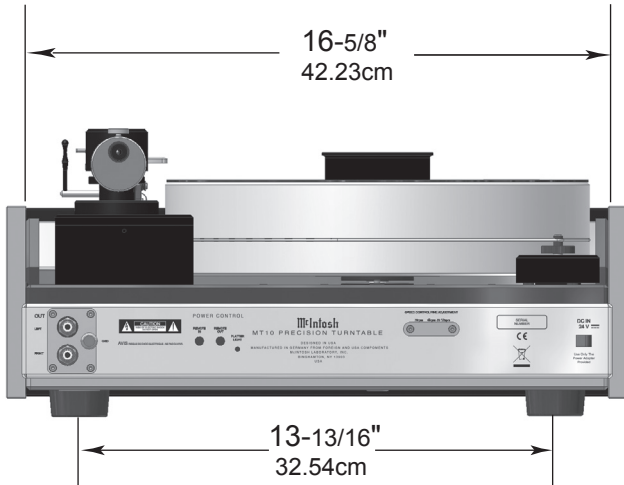

**Side View of the MT10**

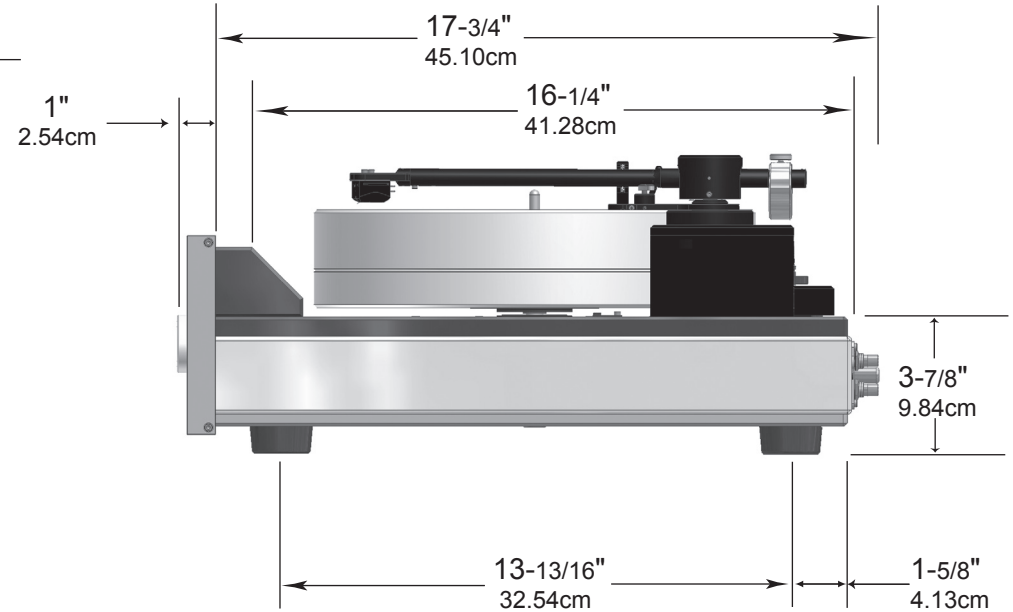

## Unpacking the Turntable

To protect the fine finish of the MT10 Precision Turntable during the assembly and adjustment process, it is advisable to prepare a suitable clean working area with a soft, clean fabric, such as a bed linen or blanket.

It is recommended that the Professionals at your McIntosh Dealer, who are skilled in all aspects of installation and operation, unpack, assemble, adjust and install the MT10 Precision Turntable and any associated audio equipment.

**CAUTION:** To prevent possible damage to the turntable platter bearing, do not move the MT10 Precision Turntable with the platter installed.

1. After opening the outer shipping carton, carefully remove the turntable inner carton (which has two foam end caps) and the turntable platter/accessory inner carton. Refer to figure 1.

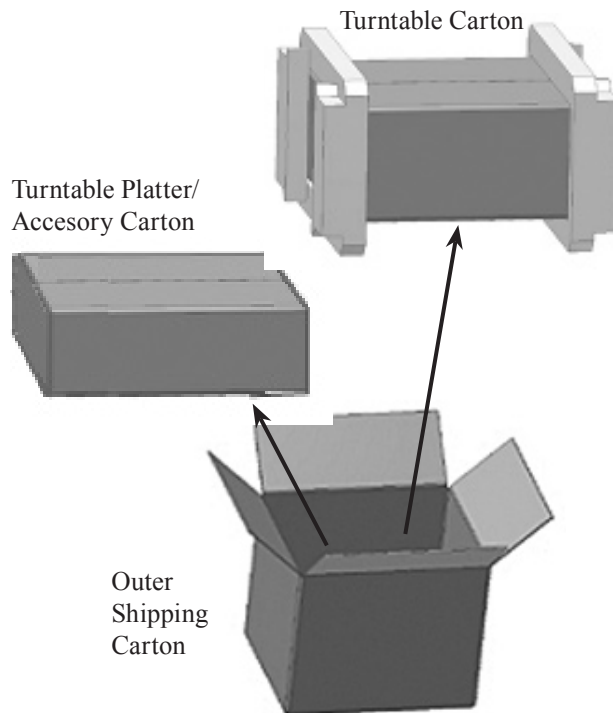

2. Open the turntable inner carton and remove the top foam pad. Refer to figure 2.

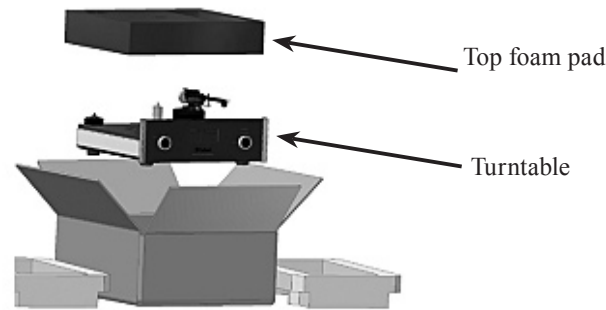

Figure 2

3. Carefully lift up on the sides of the turntable and remove it from the turntable inner carton.
4. Open the turntable platter/accessory carton and remove the the turntable platter. Refer to Figure 3

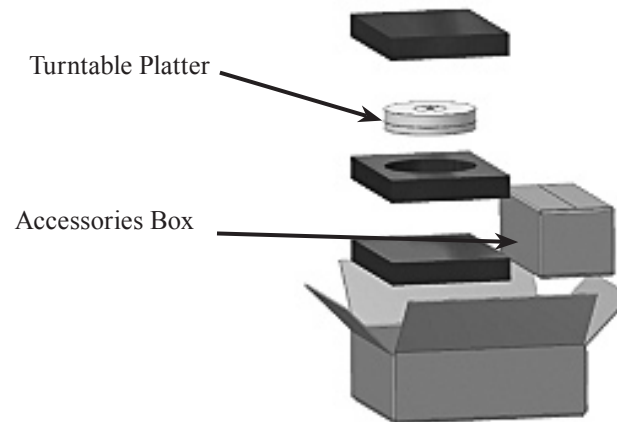

Figure 3

5. Open the accessories box and check to make sure the following items are inside:
  - A. McIntosh MCC10 Moving Coil Cartridge.
  - B. AC / DC Adapter with plug adapters.
  - C. Tonearm Counter Weight.
  - D. Turntable Record Clamp.
  - E. Turntable Bubble Level.
  - F. Assembly/Adjustment Tools.
  - G. Cartridge Mounting Hardware.
  - H. Pair of cloth gloves.
  - I. Turntable Bearing Oil (full-synthetic).
  - J. Tone Arm Height Gauge (used for MCC10 Cartridge).
  - K. Protractor.
  - M. Cloth Dust Cover.
  - N. Turntable Platter Mat.

*Note: The Turntable Platter Mat is located in an album cover and in the Turntable Platter/Accessory Carton.*

6. Proceed to Assembly of the Turntable starting on the next page.

## Assembling the Turntable

Locate the McIntosh MCC10 Moving Coil Cartridge, Tools and Mounting Hardware from the Accessory Box. In the following steps the Cartridge will be installed in the Tone Arm Headshell of the Turntable.

**CAUTION:** To prevent possible damage to the Cartridge Stylus, **DO NOT** remove the clear protective cover at this time.

- Using an appropriate tool, attach the four color coded wire lead connections coming from the front underside of the Tone Arm onto the rear of the McIntosh Moving Coil Cartridge as follows. Refer to figures 4, 5, 6 and 8.

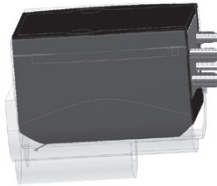

Figure 4

### Rear View of McIntosh MCC10 Cartridge

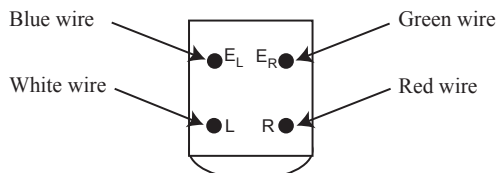

Figure 5

### Cartridge Pin Identification

Cartridge Pin Identification	Wire Color
E <sub>R</sub>	Green
R	Red
E <sub>L</sub>	Blue
L	White

- Locate in the Hardware Package two M2.5 x 4.5mm mounting screws.
- Position the Cartridge to the underside of the Tone Arm Headshell, with the top rear edge of the Cartridge parallel to and touching the machined ridge of the Headshell. Refer to figures 7 and 8.

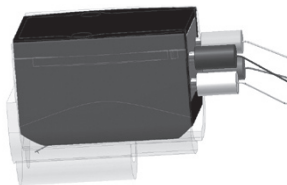

Figure 6

- Insert the two screws (from step 2) through the top of the headshell and into the Cartridge Body

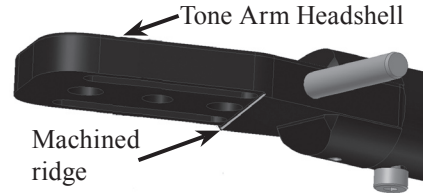

Figure 7

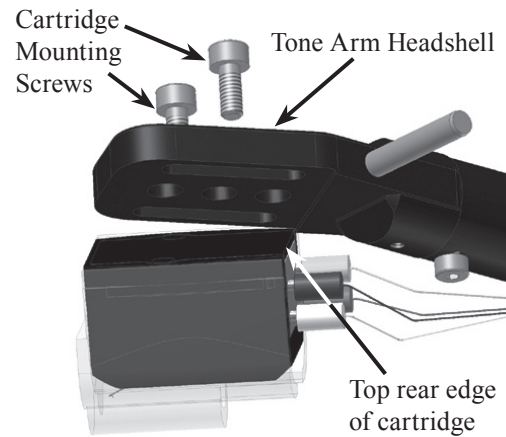

Figure 8

and fasten them with a small screwdriver. Make sure the sides of the Cartridge are parallel to the sides of the Tone Arm Headshell before tightening the screws. Refer to figure 9.



Figure 9

- Remove any shipping restraining materials from the Tone Arm Rest Holder. Refer to figure 10.
- Remove the foil tape from the Tone Arm Support Arm to free

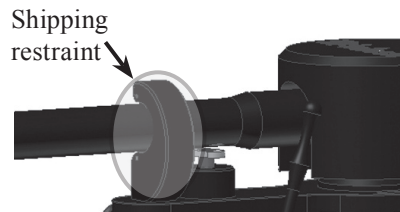

Figure 10

the Anti-Skate Cord. Refer to figure 11.

- Position the Anti-Skate Cord over the Anti-Skate Pulley. Refer to figure 12A.

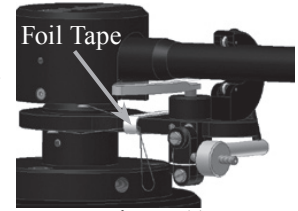

Figure 11

- Verify the correct setting of the Anti-Skate for the McIntosh Cartridge by measuring the distance as indicated in figure 12B. If the distance is not correct, first slide the "O" Ring away from the Anti-Skate Weight. Rotate the Anti-Skate Weight to set the correct distance and then slide the "O" Ring back up the Anti-Skate Weight.

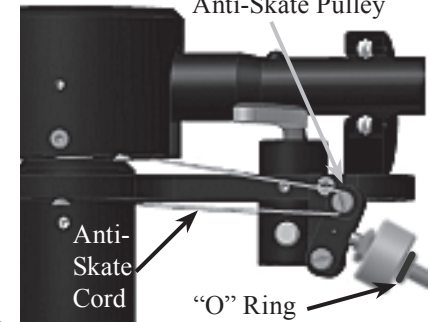

Figure 12A

- Locate the Tone Arm Counterweight. Loosen up the knurled knob to permit installing the Counterweight onto the rear of the Tone Arm. Position the Counterweight on the Tone Arm so the front surface of the Counterweight lines up with the McIntosh MCC10 Cartridge position marking on the surface. Refer to figure 13. Then tighten the knurled knob to secure the position of the Counterweight.

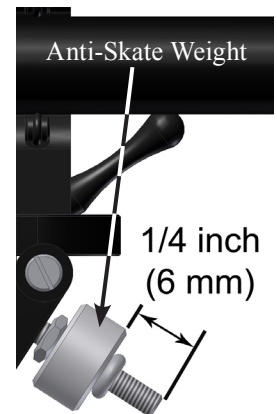

Figure 12B



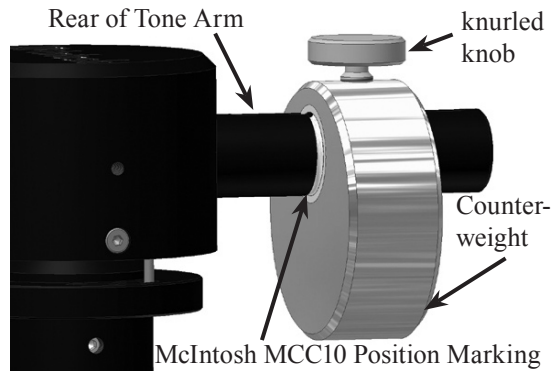

Figure 13

10. Locate the Tone Arm Height Gauge (used for the McIntosh MCC10 Cartridge) from inside the accessory box.
11. The gauge should just fit between the Tone Arm Housing and the Mounting Plate of the Tone Arm. This will verify the preset Tone Arm Height has not changed during shipping. Refer to figure 14. If the space has changed, refer to
12. Place the McIntosh MT10 Turntable in its operation location.



Figure 14

- Notes: 1. To reduce the chance of acoustic feedback, locate the turntable the greatest possible distance from the system loudspeakers.*
- 2. To minimize the possibility of the cartridge stylus jumping record grooves, place the turntable on a mechanically stable surface such as wall shelving anchored to wall studs.*

13. Remove the protective film from the Optical Sensor located on the Turntable Top Surface. Refer to figure 15.
14. Remove the protective film from the bottom of the Turntable Platter covering the Optical Ring. Refer to figure 16.

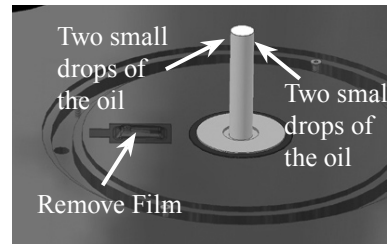

Figure 15

15. Remove the protective film from the bottom of the Turntable Vertical Bearing opening. Refer to figure 17.
16. Locate the supplied Turntable Bearing Oil and place two small drops of Oil on the top sides of the Vertical Bearing Ceramic Shaft. Refer to figure 15.

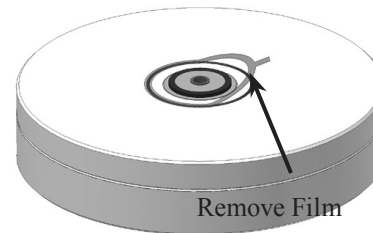

Figure 16

17. Very carefully center the Vertical Bearing Ceramic Shaft with the Vertical Bearing opening on the bottom of the Turntable Platter. Lower the Platter onto the Ceramic Shaft while keeping the platter parallel with the top surface of the Turntable. Refer to figures 18, 19 and 20.

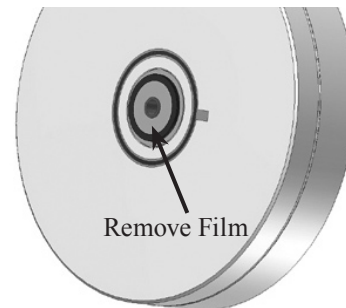

Figure 17

18. Using the supplied cloth gloves, place the belt onto the circumference of the platter and then onto the pulley of the motor. Rotate the platter by hand while seating the

belt into the recessed groove on the platter.

19. Locate the Turntable Platter Mat and place it on top of the platter.
20. Locate the McIntosh Bubble Level and place it on the Turntable Platter Mat. If the Bubble is not in the center circle of the Bubble Level, adjust the height of the Turntable Feet (by rotating them clockwise or counter clockwise) until it is level. Refer to figure 21.
21. Carefully slide off the clear protective cover from the cartridge by pulling the cover straight toward you.

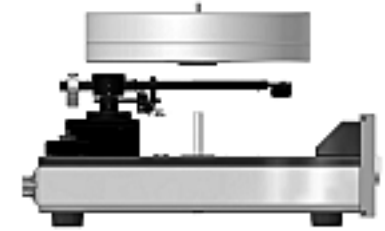

Figure 18

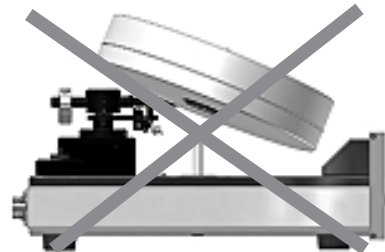

Figure 19



Figure 20

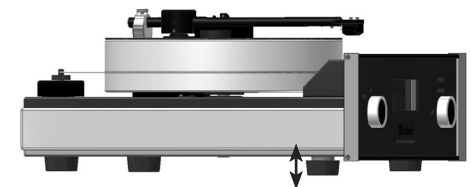

Figure 21

22. Proceed to "Rear Panel Connections and Adjustments" on page 13.

## Installing a non-supplied Cartridge

**CAUTION:** To prevent possible damage to the turntable platter bearing, do not move the MT10 Precision Turntable with the platter installed.

In the event a non-supplied Phono Cartridge is to be installed into the McIntosh MT10 Turntable please follow the steps below:

*Note: It is recommended that the Professionals at your McIntosh Dealer, who are skilled in all aspects of installation and adjustment of the McIntosh MT10 Precision Turntable perform the assembly, installation and adjustments.*

1. When a Phono Cartridge is already installed into the MT10 Turntable Tone Arm Headshell, un-install it by removing the mounting screws. Refer to figure 22. Then carefully disconnect the four push-on wire clips from the rear of the phono cartridge. Place the removed cartridge and screws in a safe place for possible future use.



Figure 22

2. Locate the Hardware Package supplied with the new cartridge.
3. Using an appropriate tool, attach the four color coded wire lead connections coming from the front underside of the Tone Arm onto the rear of the new Phono Cartridge, following the instructions supplied with the Cartridge. Below is the Tone Arm Headshell wire color lead identification:

### Wire Color

- Red - Right Channel Positive (+) Signal Connection
- Green - Right Channel Negative (-) Ground Connection
- White - Left Channel Positive (+) Signal Connection
- Blue - Left Channel Negative (-) Ground Connection

4. Position the Cartridge Spacer (supplied with the

MT10 Turntable) to the underside of the Tone Arm Headshell with the top rear edge of the Spacer parallel to and touching the machined ridge of the Headshell. Refer to figure 7 on page 8 and figure 23.

5. Position the Cartridge to the underside of the Cartridge Spacer with the sides of the Cartridge parallel to the sides of the Headshell.

Secure the Phono Cartridge Body and Cartridge Spacer to the Headshell with the mounting hardware supplied with the new Phono Cartridge using the appropriate tools. Refer to figure 24.

6. Proceed to “Tone Arm Adjustments”.

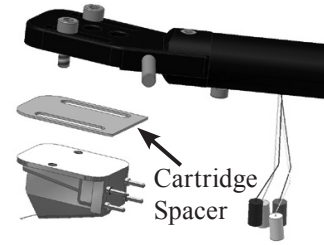

Figure 23

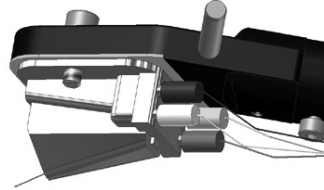

Figure 24

## Tone Arm Adjustments

### Initial setting of the Tracking Force Pressure

Using an accurate Tracking Force Gauge, adjust the position of the MT10 Tone Arm Counter Weight to establish a tracking force pressure to approximately the middle of the recommend range from the Phono Cartridge manufacturer. Refer to figure 13 on page 9.

### Phono Cartridge/Headshell Alignment

The MT10 Turntable Tone Arm, like all pivoting Tone Arms, follows a slight arc as it transverses across the surface of a phonograph record. The Tone Arm

Headshell of the MT10 Turntable allows for making adjustments (sometimes referred to as the overhang adjustment) via positioning of the Phono Cartridge relative to the Headshell. Follow the steps below using the supplied McIntosh Tone Arm/Cartridge Alignment Gauge:

1. Place the Gauge over the center spindle post on the Turntable Platter and position the Gauge so the Arrow Tip on the gauge is pointing to the center of the Tone Arm Horizontal Pivot point. Refer to figures 25 and 26.

*Note: The Top of the Tone Arm has a small circle to aid in determining the center of the Tone Arm and is located between the letters “N” and “T” of the name McIntosh.*



Figure 25

2. Carefully place the Tone Arm onto the Alignment Gauge with the diamond tip of the stylus on the small circle located between the parallel lines. Refer to figures 27 and 28.

*Note: It may be necessary to slide the Phono Cartridge forwards or backward in the headshell to position the stylus in the center of the circle.*

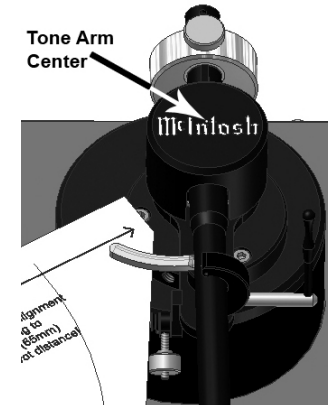

Figure 26

3. It is important the Front and Sides of the Phono Cartridge Body line up with these parallel lines when looking down over the top of the Tone Arm. Refer to figures 28 and 29. If it is not parallel, loosen the mounting hardware securing the Phono Cartridge to the Tone Arm. Reposition the Phono Cartridge so the diamond tip of the stylus is in the center of the small circle and the Front and Sides of the Phono Cartridge are parallel to the lines on the Alignment Gauge. Tighten up the mounting hardware and verify the correct alignment.



Figure 27

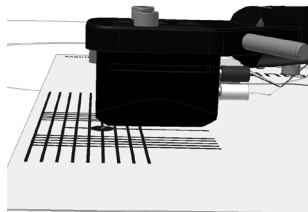

Figure 28

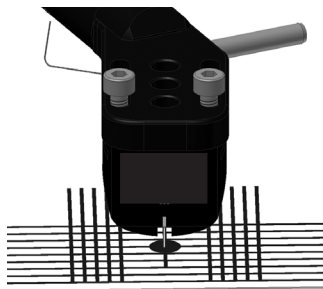

Figure 29

4. Set the desired tracking force pressure by using the accurate Tracking Force Gauge and adjust the position of the MT10 Tone Arm Counter Weight.

*Note: Adjusting the tracking force pressure closer to the maximum setting recommend by the Phono Cartridge Manufacturer will produce better sound and less record and stylus wear than setting the tracking force pressure to the minimum setting.*

## Tone Arm Height

To assure the best sound reproduction, it is very important the MT10 Tone Arm is parallel to the record surface during playback. The height of the Tone Arm is adjustable to accommodate the different Phono Cartridge physical heights. To adjust for the proper Tone Arm Height, perform the following the steps:

1. Release the Tone Arm from the Tone Arm Rest, place it on a record and check to see if the Tone Arm is parallel to the surface of the record. With the Tone Arm parallel, no adjustment is needed and proceed to "Trackability Adjustments". If the Tone Arm is not parallel, note whether the rear of the Tone Arm needs to go up or down.
2. With the Tone Arm secured in the Tone Arm Rest, carefully loosen the two set screws while supporting the rear of the Tone Arm. Reposition the Tone Arm based on findings in the previous step. Temporarily tighten one of the set screws. Refer to figure 30.
3. Release the Tone Arm from the rest and place it on a record and check to see if the Tone Arm is now

parallel. Also check to make sure the Tone Arm is parallel to the record platter and the right side of the turntable base. Refer to figure 29.

4. With the Tone Arm parallel to the record surface, record platter and turntable base tighten both set screws, which were loosened in step 2. If not, repeat steps 1, 2 and 3 until the Tone Arm is parallel.

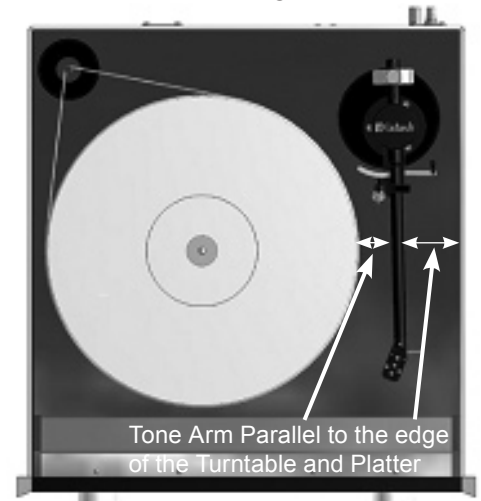

Figure 31

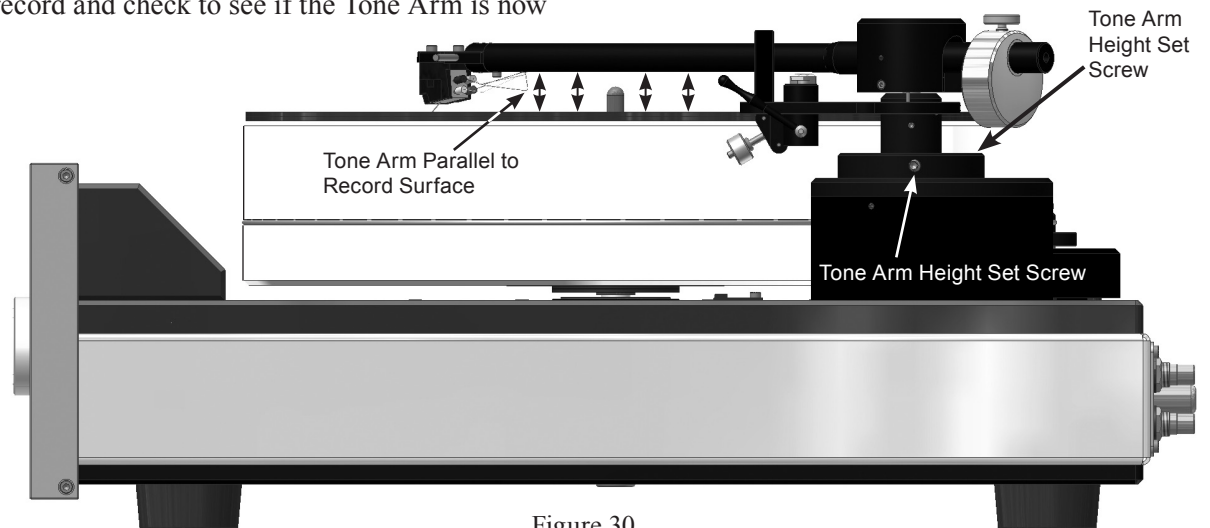

Figure 30

### Tone Arm Lift Height

The MT10 Tone Arm Lift is pre-adjusted to accommodate the combined thickness of the supplied Turntable Record Mat and Phonograph Records. If a different Record Mat and/or thicker Phonograph Record are used, there may not be sufficient clearance between the Phono Cartridge Stylus and the Phonograph Record surface with the Tone Arm Lift in the cue up position. Perform the following steps to readjust the Tone Arm Lift:

1. Secure the Tone Arm in the Tone Arm Rest.

*Note: Before making any adjustments to the Tone Arm Lift check to see if the Tone Arm is parallel to the record surface when playing a record first. See "Tone Arm Height" section on page 11.*

2. Using the appropriate tool, carefully loosen the Set Screw while supporting the bottom the Tone Arm Lift. Refer to figure 32.

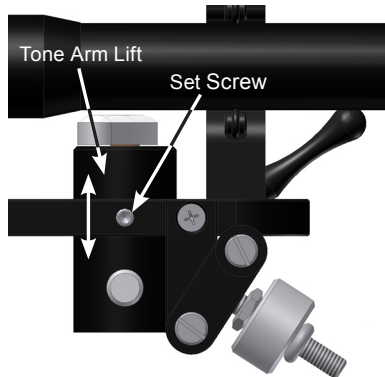

Figure 32

3. Re-position the Tone Arm Lift Mechanism upwards slightly and then tighten the Set Screw.

4. Check the clearance between the Phono Cartridge Stylus and the Phonograph Record surface with the Tone Arm Lift in the cue up position. If necessary, readjust the position of the Tone Arm Lift and re-check.

5. With the Turntable stopped and no Phonograph record on the record mat, make sure the Phono Car-

tridge Stylus comes in contact with the record mat with the Tone Arm Lift in the down position.

### Trackability Adjustments

During playback of Phonograph Recordings, the Diamond tip of the stylus assembly is subjected to all kinds of extreme operating conditions. One of those conditions is the forces constantly trying to push the stylus up and out of the grooved wall of the recording. The Tracking Force Pressure is applied in a downward direction to keep the stylus in contact with the groove wall. Another condition is the uneven side to side pressure applied to the stylus as it tries to stay in contact with both sides of the groove wall of the recording. Refer to figure 33.

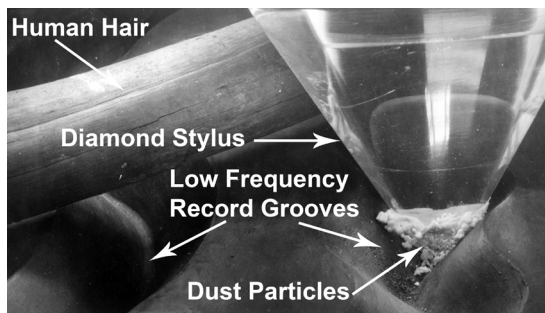

Figure 33

This is a function of all pivoting Tone Arms where the headshell is usually angled inwards to minimize the playback arc. The Anti-Skating Adjustment of the MT10 Tone Arm permits equalizing for even side to side pressure.

The correct amount of Tracking Force Pressure and Anti-Skate Pressure varies with the exact shape of the Diamond Stylus Tip, Tone Arm Characteristics and finally the audio signal (both frequency and amplitude)

contained in the groove wall of the record playing.

The way to achieve the best performance and the least amount of Diamond Stylus Tip/Record Groove wear is to use special test recordings, such as the Shure Trackability Test Record (TTR101). Both Tracking Force and Anti-Skate Adjustments are made as a result of listening to the specially recorded tracks and following the instructions to reduce different forms of audible distortions. Refer to figures 34 and 35.

While making these adjustments, do not exceed the manufacturers recommend Maximum Tracking Force Pressure Setting.

Your McIntosh Dealer, using Test Measurement Equipment and Professional Test Recordings, can achieve via adjustments, the best possible sound quality from your record collection and ensure the greatest longevity.

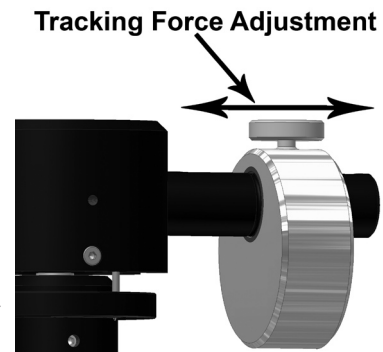

Figure 34

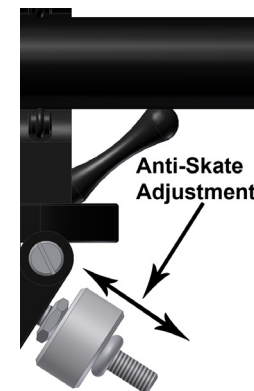

Figure 35

## Rear Panel Connections and Adjustments

AUDIO OUTPUTS connect to MC (Moving Coil) Inputs of the Preamplifier or A/V Control Center when the McIntosh MCC10 Cartridge is installed. Contact your McIntosh Dealer for additional assistance

GND (Ground) connects to GND (Ground) connection on the Preamplifier or A/V Control Center

Connect to the AC / DC Adapter supplied with the MT10 Turntable. Then connect the AC / DC Adapter to a live AC outlet. Refer to information on the Power Supply to determine the correct voltage

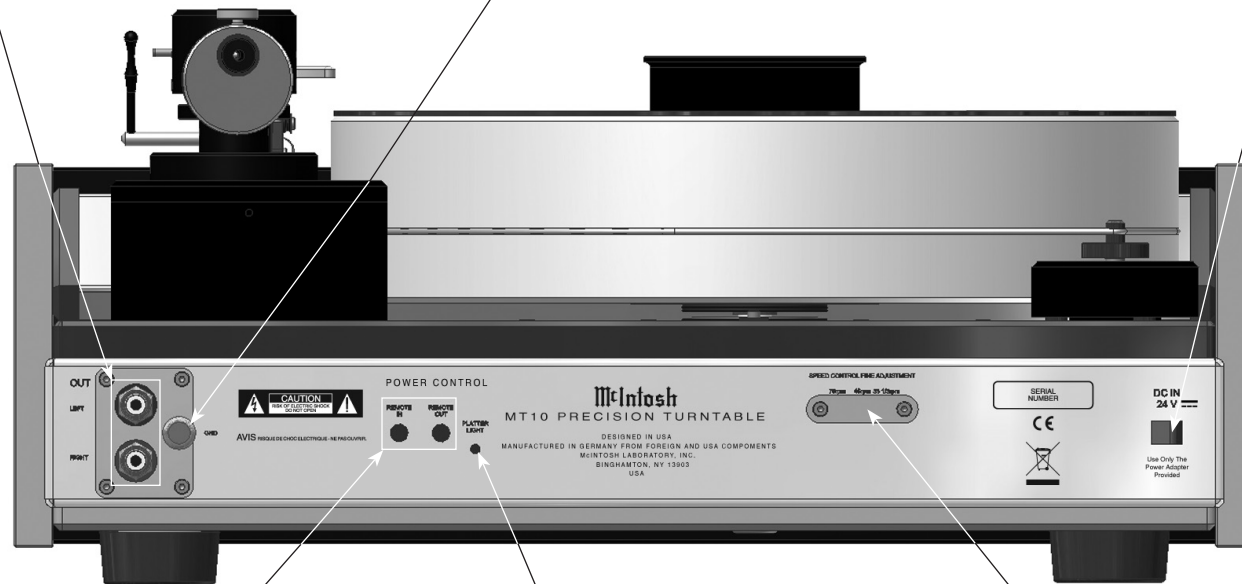

POWER CONTROL REMOTE IN receives turn-on signals from a McIntosh component and switches the Front Panel Illumination On/Off.  
POWER CONTROL REMOTE OUT sends turn-on signals on to another McIntosh Component

PLATTER LIGHT  
Fine adjustment of the Turntable Platter Illumination level

Fine speed adjustments for 33-1/3, 45 and 78 rpm. These Adjustments require special test records and precision measurement equipment to accurately set the speeds. Contact your McIntosh Dealer for assistance

## How to Connect the Turntable

1. Connect a Power Control Cable from the MT10 POWER CONTROL REMOTE IN to the POWER CONTROL ACC Output jack of a McIntosh Pre-amplifier or A/V Control Center.
2. Optionally, connect a Power Control Cable from the MT10 POWER CONTROL REMOTE OUT to the POWER CONTROL IN jack of a McIntosh source component.
3. Connect a wire from the MT10 GND (Ground) Post to the GND (Ground) post on the McIntosh Pre-amplifier or A/V Control Center.
4. Connect Audio Cables from the MT10 OUT L and R jacks to the MC (Moving Coil) Inputs on a McIntosh Pre-amplifier or A/V Control Center.

*Note: The MT10 Turntable with the MCC10 Moving Coil Cartridge should produce a satisfactory volume level when connected to a Pre-amplifier or A/V Control Center with a Moving Magnet Phono Input. If additional volume level is desired, an in-line Pre-Pre-amplifier or step up transformer may be added. Contact your McIntosh Dealer for additional information and assistance.*

5. Connect the supplied AC / DC Adapter to the MT10 DC IN 24V socket and the Power Supply to a live AC outlet.

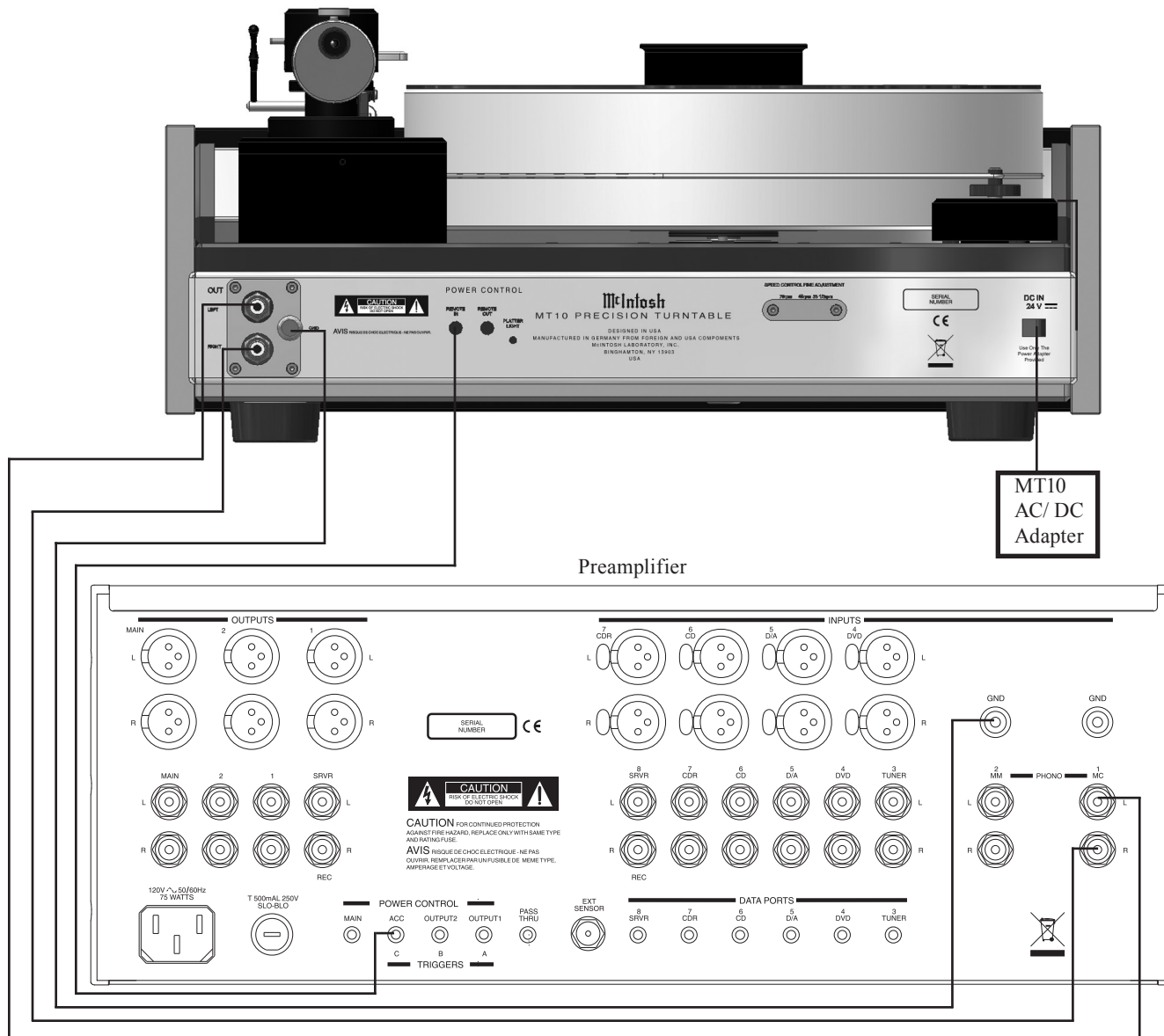



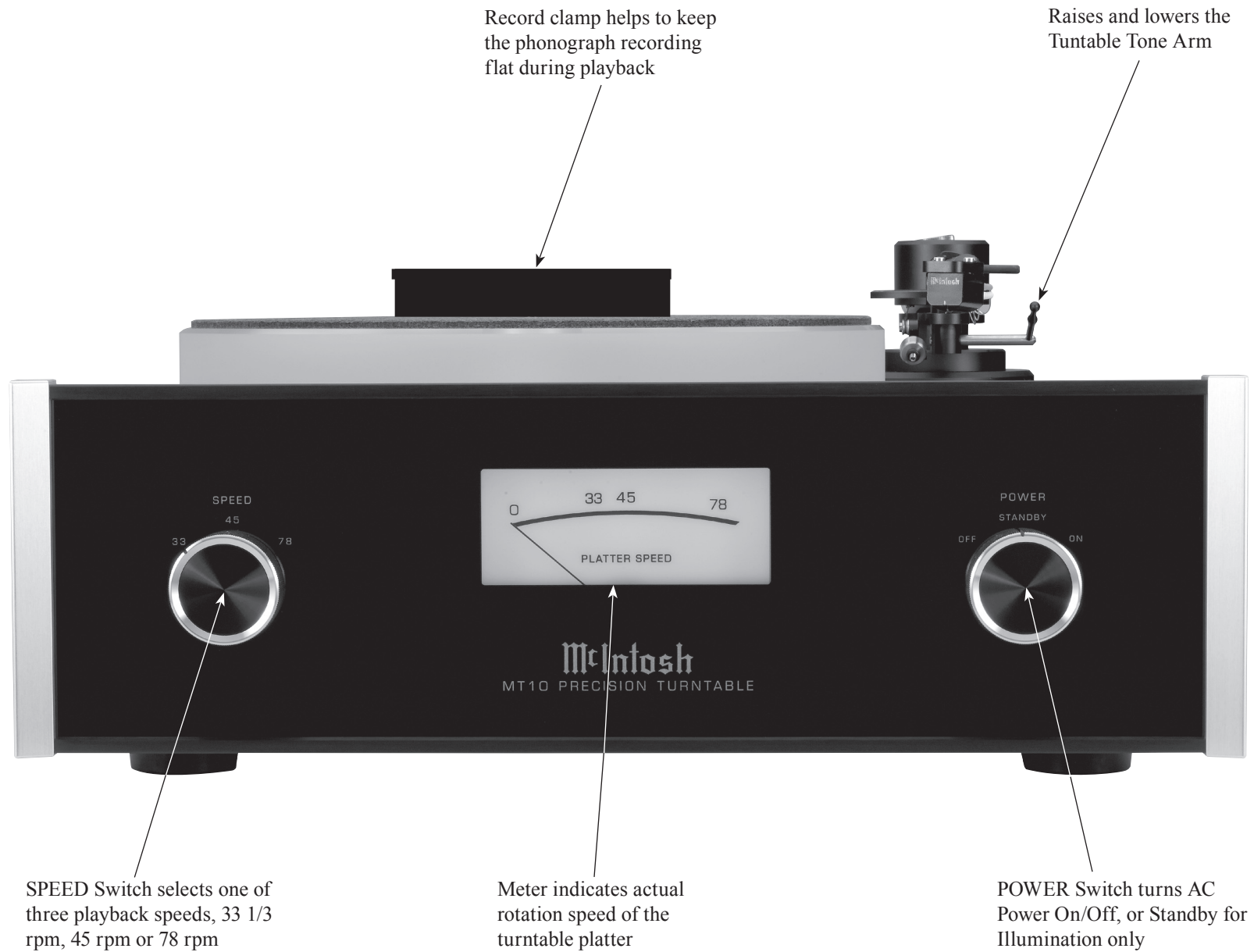



## How to Operate the Turntable

### Power Selection

Rotate the POWER Switch to select the Turntable operation mode desired. Refer to figure 50.

**Power Off** - The Front Panel and Turntable Platter lights are turned Off. There is no Turntable Platter rotation.

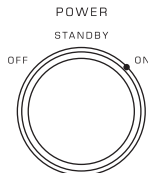

Figure 50

**Standby** - The Front Panel and Turntable Platter will illuminate when the McIntosh Preamplifier or A/V Control Center is turned On. There is no Turntable Platter rotation.

*Note: There must be a power control connection between the MT10 and the McIntosh Preamplifier or A/V Control Center, in order for the Standby Mode to function.*

**On** - The Front Panel and Turntable Platter lights are turned On. The Turntable Platter will rotate at the selected speed.

### Speed Selection

Rotate the SPEED Switch to select the playback speed (33-1/3 rpm, 45 rpm or 78 rpm) of the phonograph record to be played. Refer to figure 51.

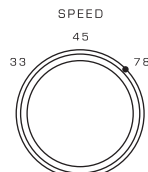

Figure 51

The Front Panel Platter Speed Meter indicates the actual speed of the Turntable Platter during playback of the recording. Refer to figure 52.

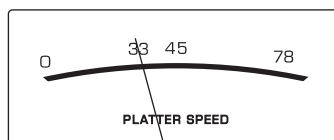

Figure 52

### Tone Arm Lift

The McIntosh MT10 Precision Turntable has a built-in manual Tone Arm Lift Mechanism for safe placement and removal of the cartridge stylus on the phonograph record. Perform the following steps:

1. Push on the top part of the Tone Arm Lift Lever towards the rear of the turntable. Refer to figure 53.

Tone Arm Lift Lever

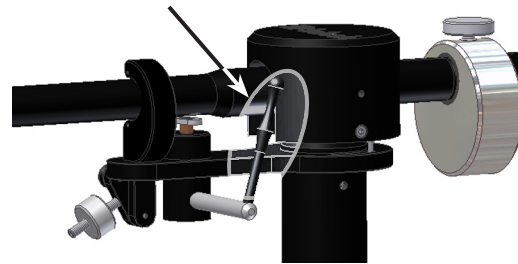

Figure 53

2. Release the Tone Arm from the Tone Arm Holder. Refer to figure 54.

Tone Arm Holder

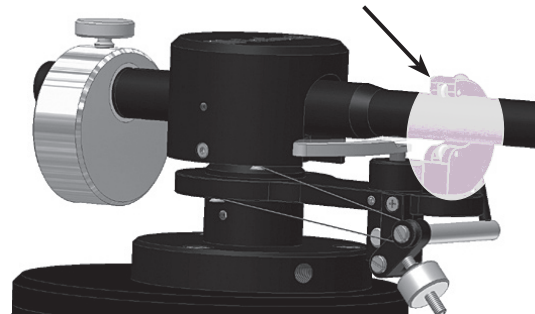

Figure 54

3. Position the Tone Arm over the desired spot of the Phonograph record.
4. Pull on the top part of the Tone Arm Lift Lever towards the front of the turntable to begin playback.



### MCC10 Cartridge Specifications

**Output Level**

0.5 mV at 5 cm/s

**Load Impedance**

400 ohms recommended

**Frequency Response**

20Hz to 50,000Hz

**Channel Separation**

Greater than 30dB at 1kHz

**Compliance**

6 x 10<sup>-6</sup> cm/dyne

**Recommended Tracking Force**

2.4 g

**Channel Difference**

Less than 0.3 dB

**Total Mass**

11 g

**Stylus**

Elliptical Diamond

**Cantilever Material**

Aluminum

**Coil Assembly**

Symmetric design

### MT10 Turntable Specifications

**Playback Speeds**

33 1/3 rpm, 45 rpm and 78 rpm

**Motor Type**

DC Brushless

### General Specifications

**Overall Dimensions**

Width is 17-1/2 inches (44.45cm)

Height is 8-13/16 inches (22.38cm)

Depth is 21 inches (53.34cm)

*Note: Tone Arm Height will vary depending on the type of Cartridge installed.*

**Weight**

42 pounds (19.0Kg) net, 63 pounds (28.6Kg) in shipping carton

**Shipping Carton Dimensions**

Width is 24 inches (61cm)

Depth is 27 inches (68.6cm)

Height is 25 inches (63.5cm)

**Packing Instructions**

In the event it is necessary to repack the equipment for shipment, the equipment must be packed exactly as shown below. It is very important the four feet are still attached to the bottom of the equipment. This will ensure the proper equipment location on the bottom pad. Failure to do this will result in shipping damage.

Use the original shipping carton and interior parts only if they are all in good serviceable condition. If a shipping carton or any of the interior part(s) are needed, please call or write Customer Service Department of McIntosh Laboratory. Refer to page 3. Please refer to the Part List below for the correct part numbers.

Quantity	Part Number	Description
1	034420	Outer shipping carton only
1	034424	Turntable Platter/Accessories Inner carton only
2	034425	Top and bottom foam pad
1	034426	Center foam pad
1	034427	Accessory box
1	034421	Turntable Inner carton only
1	034422	Turntable Top foam pad
1	034419	Bottom locating pad
2	034423	End caps

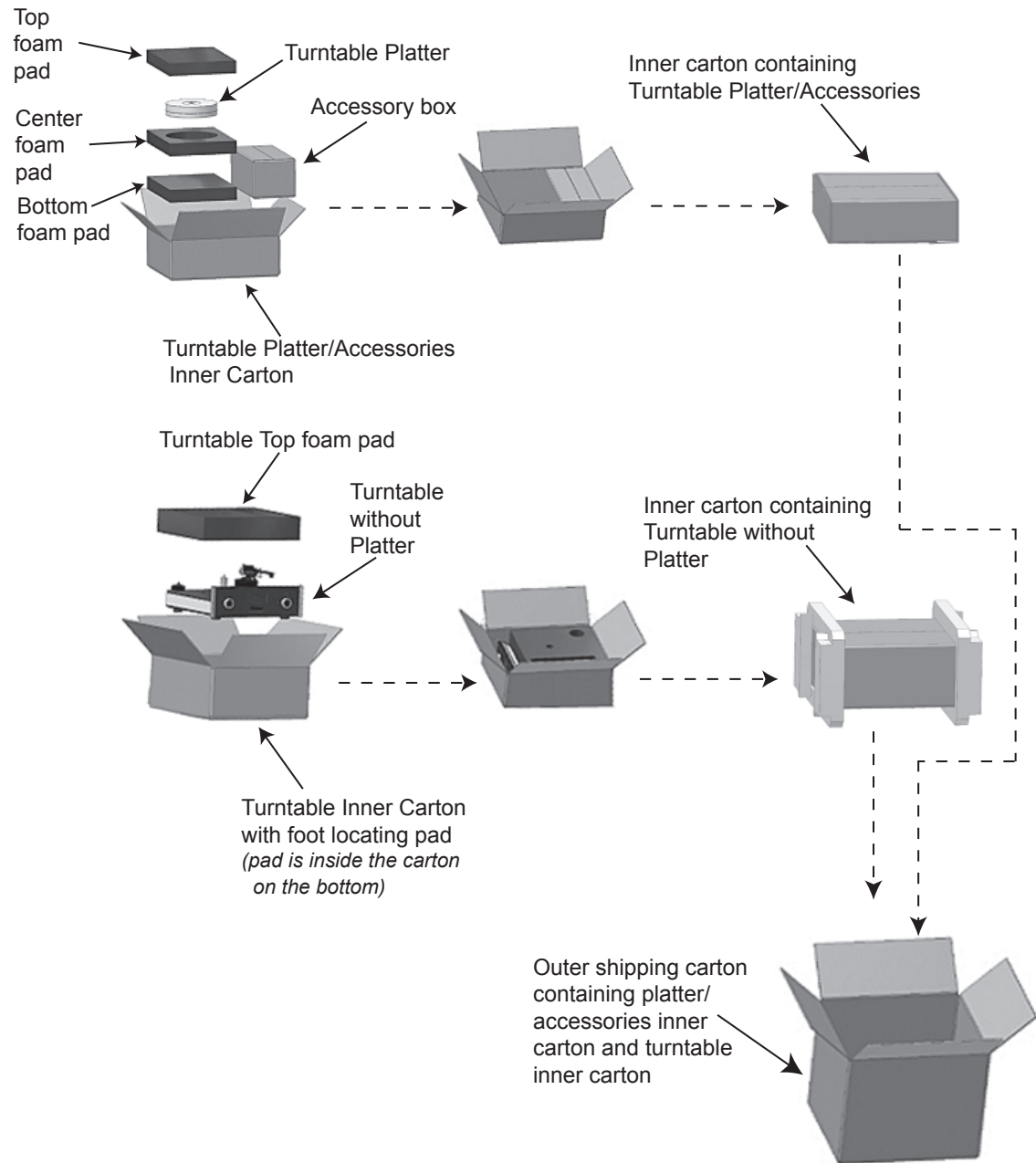



McIntosh Laboratory, Inc.  
2 Chambers Street  
Binghamton, NY 13903  
[www.mcintoshlabs.com](http://www.mcintoshlabs.com)

The continuous improvement of its products is the policy of McIntosh Laboratory Incorporated who reserve the right to improve design without notice.  
Printed in the U.S.A.