

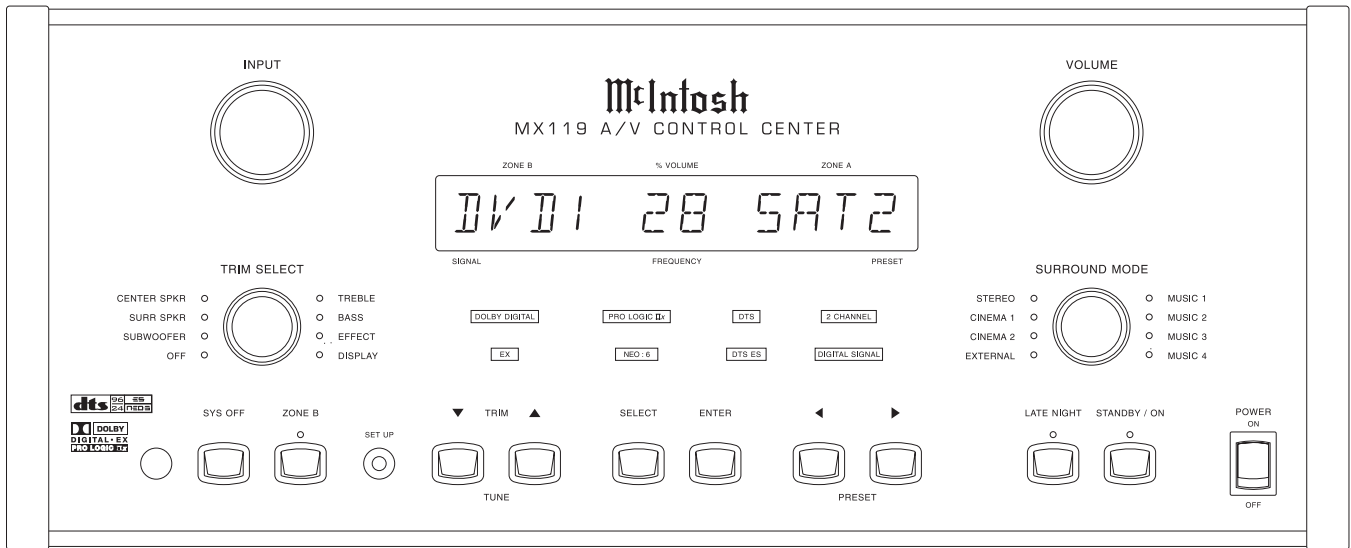

MX119

A/V CONTROL CENTER

SERIAL NO. VS1001 And Above



CONTENTS

Performance Specifications	2 - 3	Video Schematic and PCB	41 - 44
Notes	3	Input Schematic and PCB	45 - 50
Rear Panel	3	Component Video Schematic and PCB	51 - 54
Section Location	4	Tuner Schematic and PCB	55 - 56
Block Diagram	5 - 8	Tuner AM/FM Alignment Procedure	57 - 58
Interconnection Diagram	9 - 10	RAA1 Schematic and PCB	59 - 60
Display Schematic and PCB	11 - 18	Parts List	61 - 76
Surround Schematic and PCB	19 - 32	Exploded Views and Parts Lists	77 - 80
Data Schematic and PCB	33 - 36	Repacking Instruction	81
S-Video Schematic and PCB	37 - 40		

SERVICE MANUAL

Serial Number VS1001 And Above

PERFORMANCE SPECIFICATIONS

FM Tuner

Useable Sensitivity

14dBf which is 1.4uV across 75 ohms

50dB Quieting Sensitivity

Mono: 19dBf which is 2.4uV across 75 ohms

Stereo: 35dBf which is 15uV across 75 ohms

Signal To Noise Ratio

Mono: 75dB

Stereo: 70dB

Frequency Response

Mono: +0, -1dB from 20 to 15,000Hz

Stereo: +0, -1dB from 20 to 15,000Hz

Harmonic Distortion

Mono: 0.3% at 100Hz, 0.3% at 1,000Hz, 0.3% at 10,000Hz

Stereo: 0.45% at 100Hz, 0.45% at 1,000Hz, 0.65% at 10,000Hz

Intermodulation Distortion

Mono: 0.25%

Stereo: 0.45%

Capture Ratio

1.2dB

Alternate Channel Selectivity

75dB

Spurious Response

100dB

Image Response

75dB

RF Intermodulation

65dB

Stereo Separation

45dB at 100Hz, 45dB at 1,000Hz, 35dB at 10,000Hz

SCA Rejection

65dB

AM Tuner

Sensitivity

20uV external antenna input

Signal To Noise Ratio

48dB at 30% modulation

58dB at 100% modulation

Harmonic Distortion

0.5% maximum at 50% modulation

Frequency Response

50Hz to 6kHz NRSC

Adjacent Channel Selectivity

45dB minimum IHF

Image Rejection

65dB minimum from 540 to 1600kHz

IF Rejection

80dB minimum

Audio

Frequency Response

Stereo:

Left and Right Small speakers: 80Hz-20,000Hz

Subwoofer: 20Hz-80Hz

Left and Right Large speakers: 20Hz-20,000Hz

Subwoofer: OFF

Pro-Logic II: (*Movie Processing Mode*)

Left, Center, Right, Small speakers: 80Hz-20,000Hz

Surround Small speakers: 80Hz-7kHz

Subwoofer: 20Hz-80Hz

(*Music Processing Mode*)

Left, Center, Right, Large speakers: 20Hz-20,000Hz

Surround Large speakers: 20Hz-20,000Hz

Subwoofer: OFF

Dolby Digital and DTS:

Left, Center, Right, Small speakers: 80Hz-20,000Hz

Surround Small speakers: 80Hz-20,000Hz

Subwoofer: 20Hz-80Hz

Left, Center, Right Large speakers: 20Hz-20,000Hz

Surround Large speakers: 20Hz-20,000Hz

Subwoofer: 20Hz-80Hz

External Input

Left, Center, Right, Left Surround, Right Surround:
20Hz-20,000Hz

Subwoofer: 20Hz-20kHz (no LP filtering)

Rated Output

All Modes: 2.0Vrms for full bit digital input

Input Impedance

High Level: 22k ohms

Phono: 47k ohms, 65pf

PERFORMANCE SPECIFICATIONS *con't*

Output Impedance

100 ohms unbalanced
200 ohms balanced

Maximum Output Voltage

9.5 Vrms

Total Harmonic Distortion

0.005% at all outputs

Sensitivity

Analog Input: 400mV for 2.0V output

Signal To Noise Ratio – All Outputs

0.005% maximum from 20Hz to 20,000 Hz at rated output.

Maximum Input Signal

Analog Input: 6Vrms

Voltage Gain

Analog Input to Output: 14db

Frequency Response

+0, -0.5dB from 20Hz to 20,000Hz

Tone Controls

+12dB, -12dB from flat setting

General Specifications

Power Requirements

100 Volts, 50/60Hz at 65 watts
110 Volts, 50/60Hz at 65 watts
120 Volts, 50/60Hz at 65 watts
220 Volts, 50/60Hz at 65 watts
230 Volts, 50/60Hz at 65 watts
240 Volts, 50/60Hz at 65 watts

NOTE: Refer to the rear panel of the MX119 for the correct voltage.

Overall Dimensions

Width is 17-1/2 inches (44.45cm)
Height is 7-5/8 inches (19.37cm) including feet
Depth is 18-3/4 inches (47.63cm) including the Front Panel and Knobs

Weight

27 pounds (12.25kg) net, 46 pounds (20.87kg) shipping weight

NOTES

1. The heavy lines on the schematic denote the primary signal path.
2. Unless otherwise noted, all voltages indicated on the schematics are measured under the following conditions:
 - a. AC input at 120 volts, 50/60Hz.
 - b. All voltages are +/-10% with respect to ground. A high impedance (10 megaohm) voltmeter must be used.
4. On PC board drawings, Square pad indicates:
 - a. Polarized Capacitors - Positive
 - b. Diodes - Cathode
 - c. Others - Pin 1
5. **WARNING**
Parts marked with the symbol  have critical characteristics. Use only replacement parts recommended by the manufacturer.

REAR PANEL

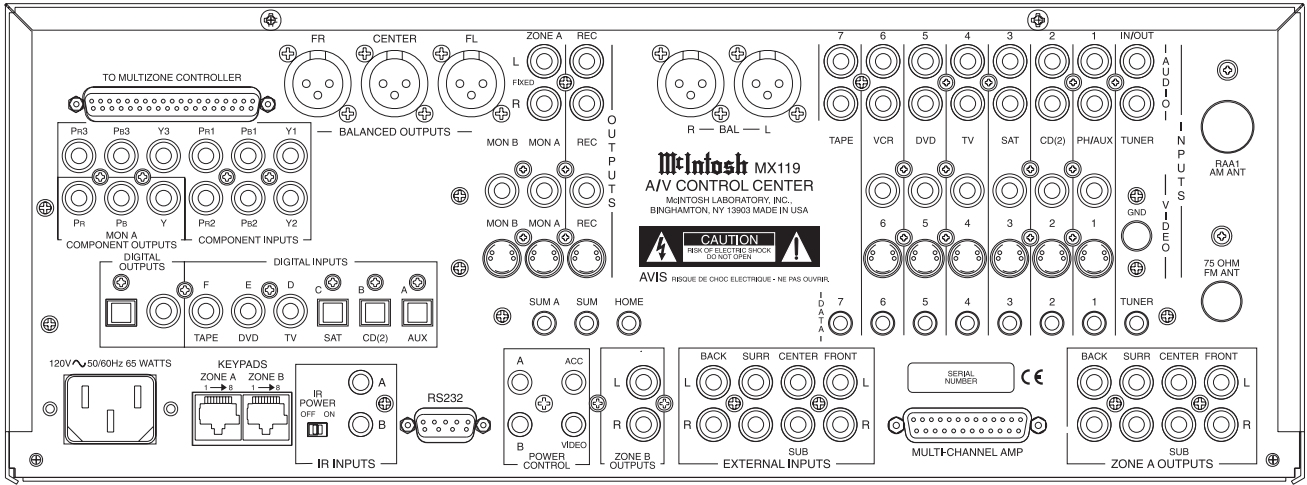

SECTION LOCATION

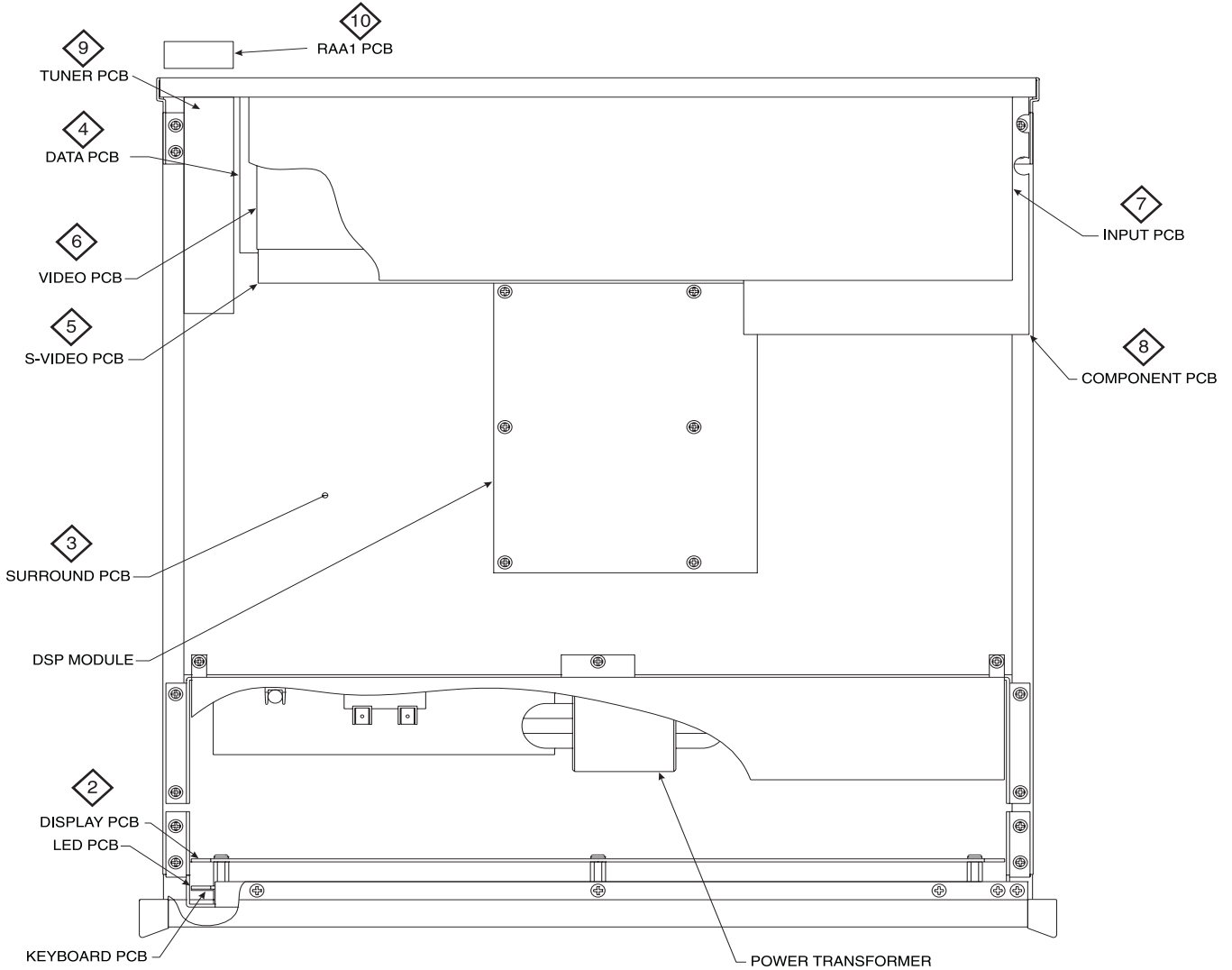

BLOCK DIAGRAM

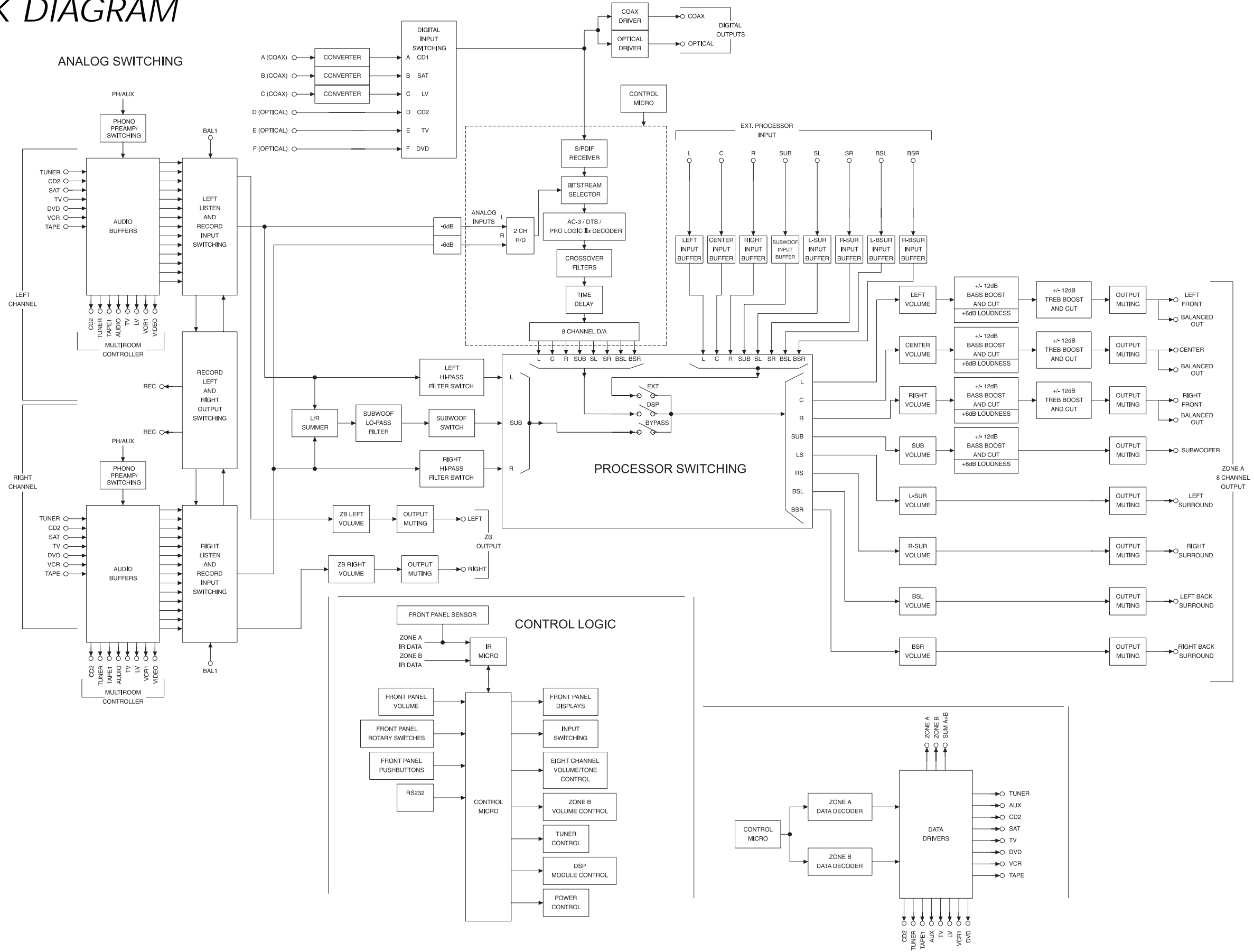

BLOCK DIAGRAM con't

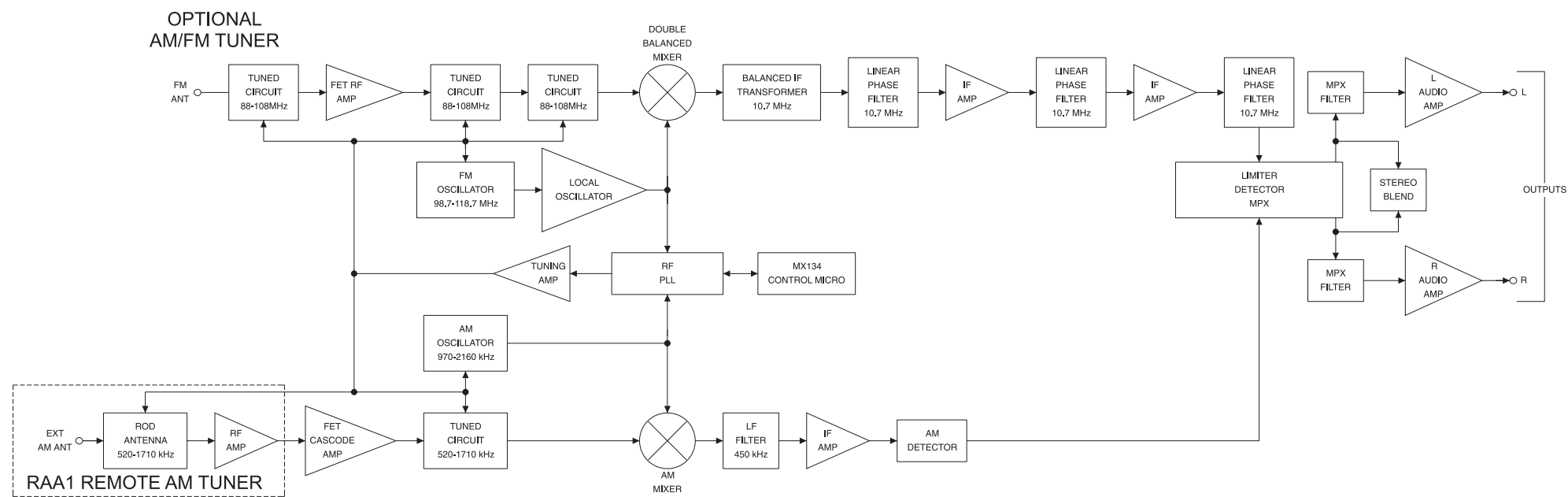
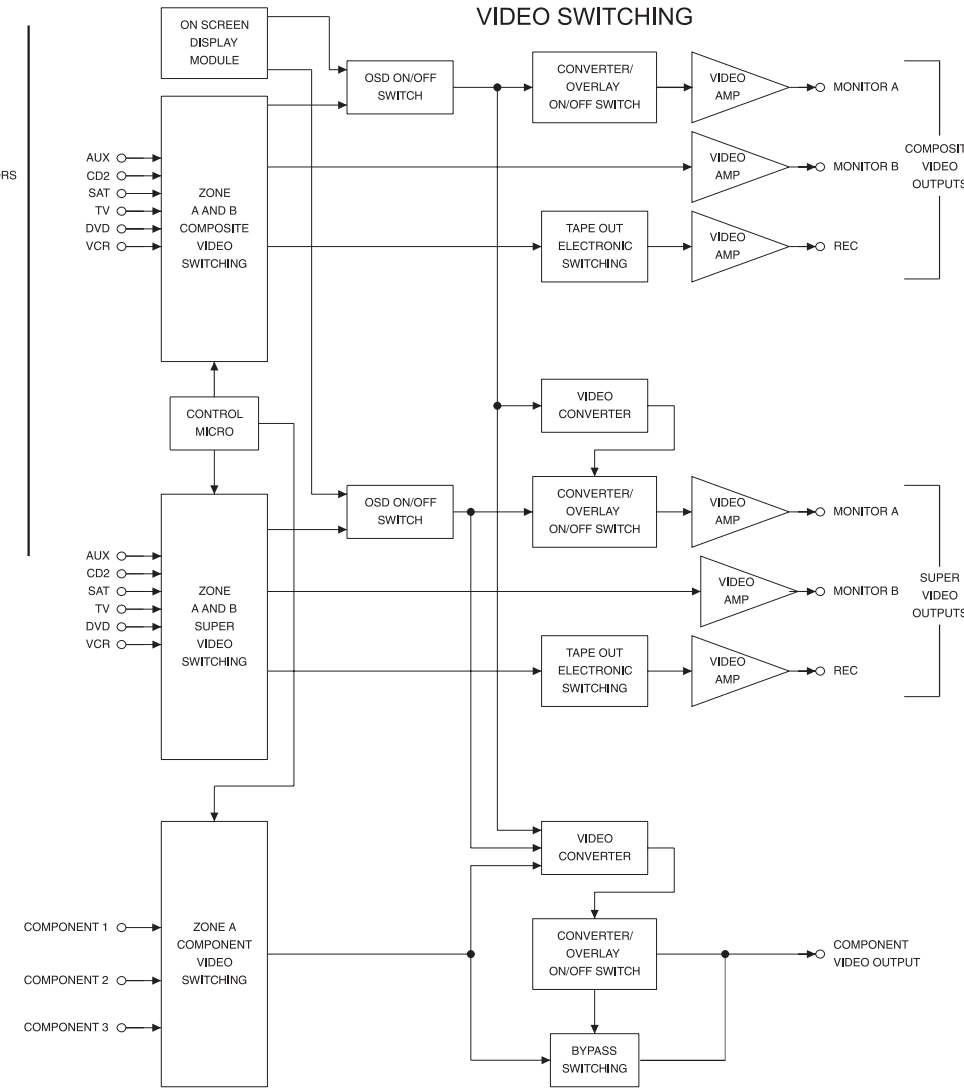
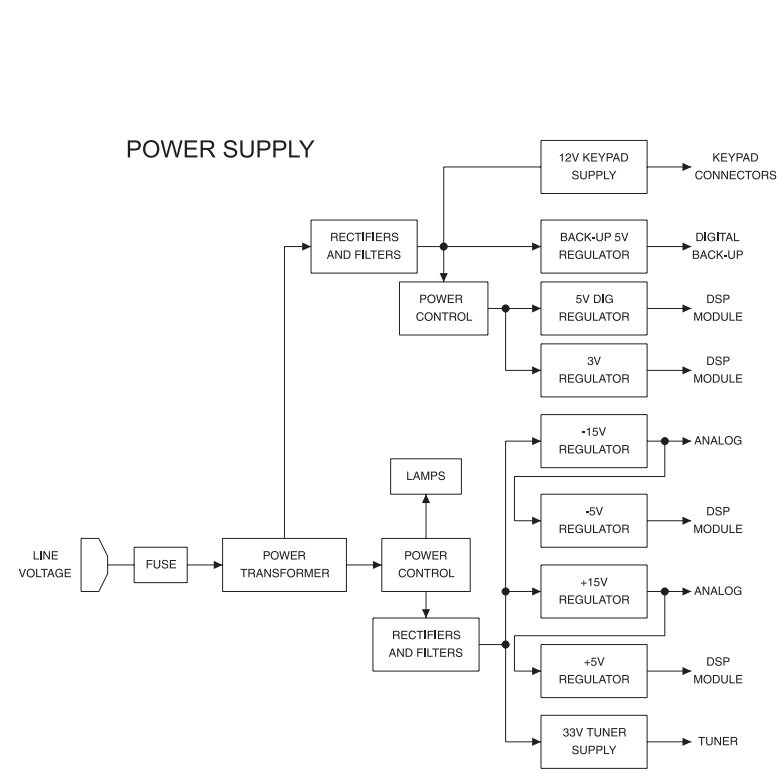

1 INTERCONNECT

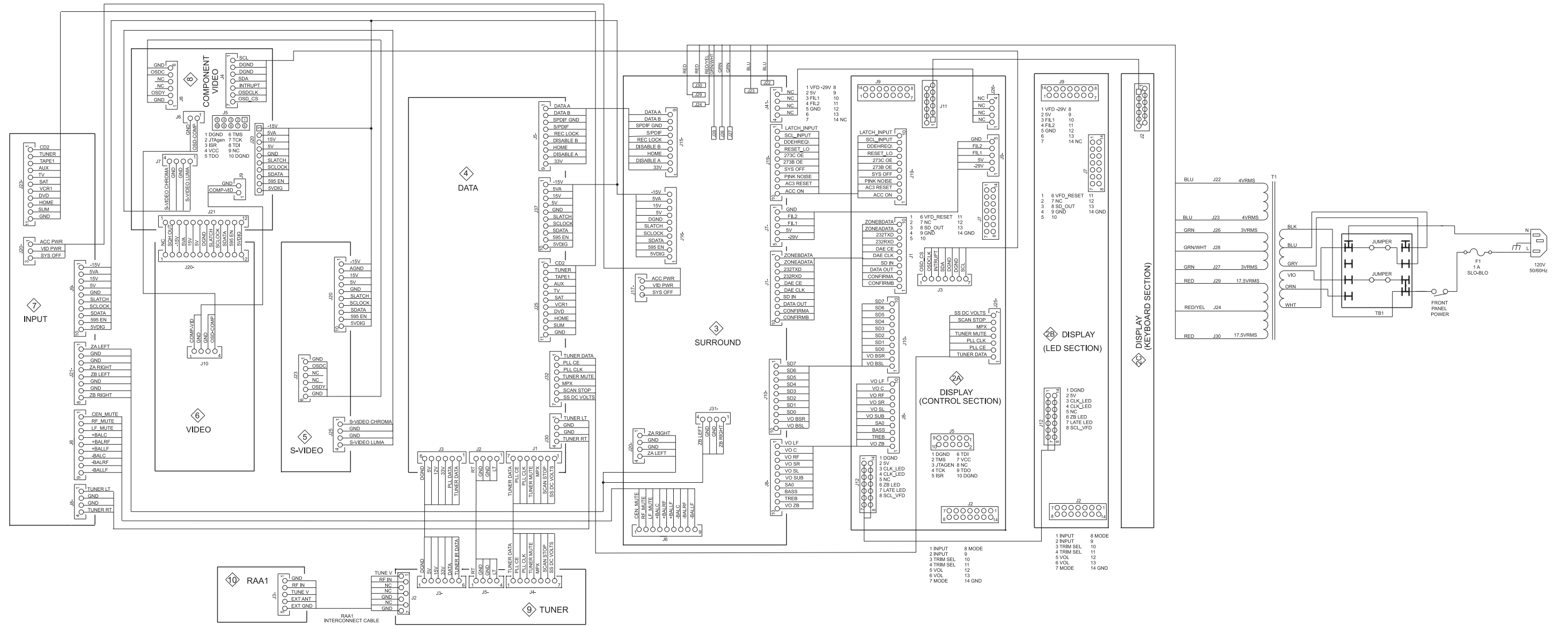

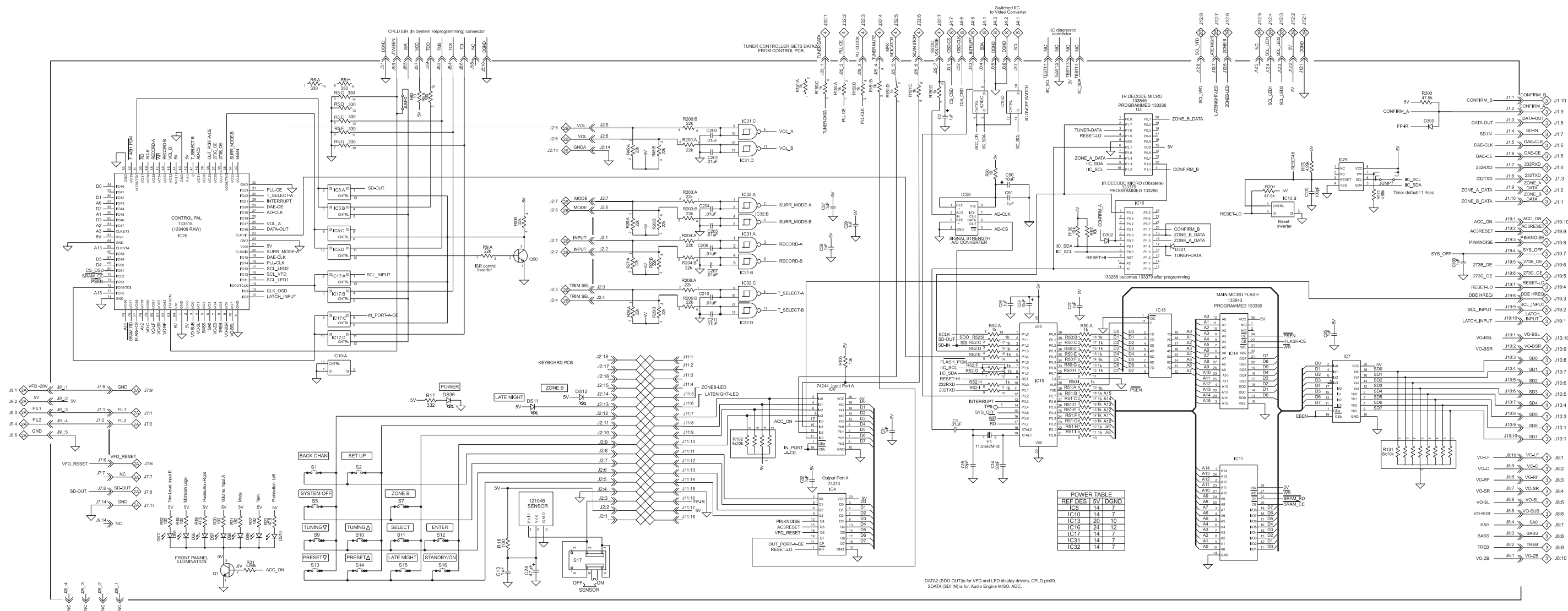

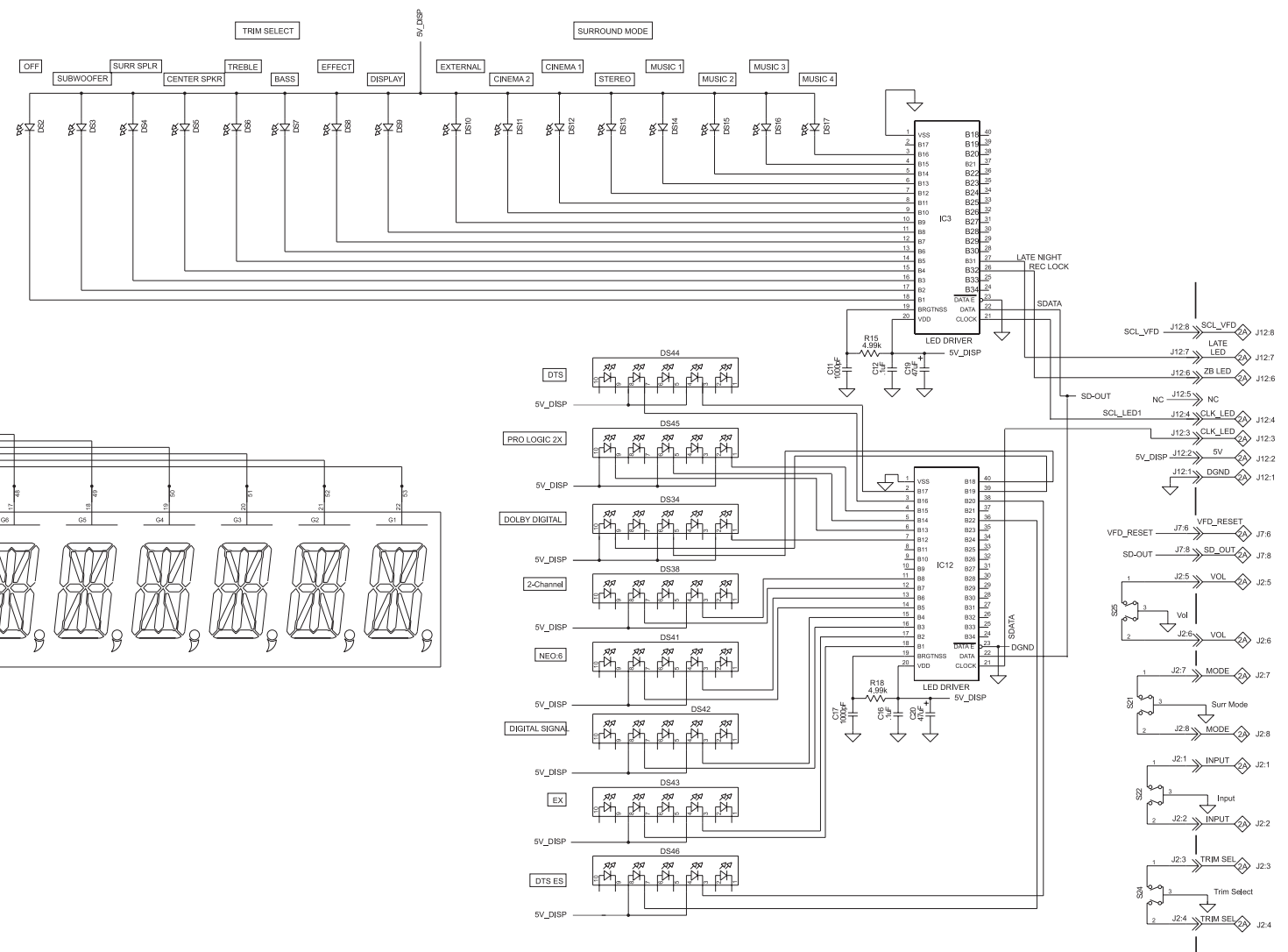
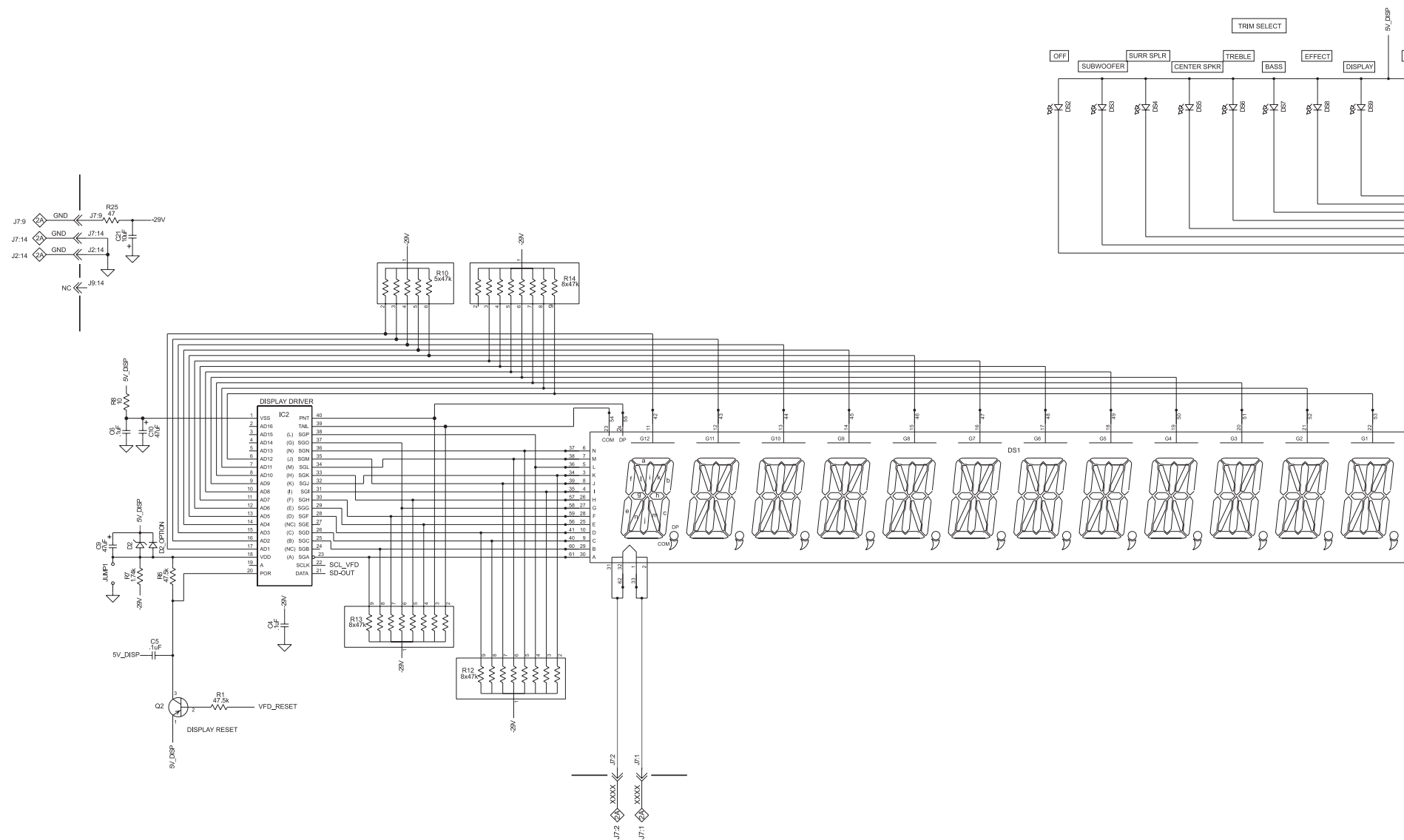

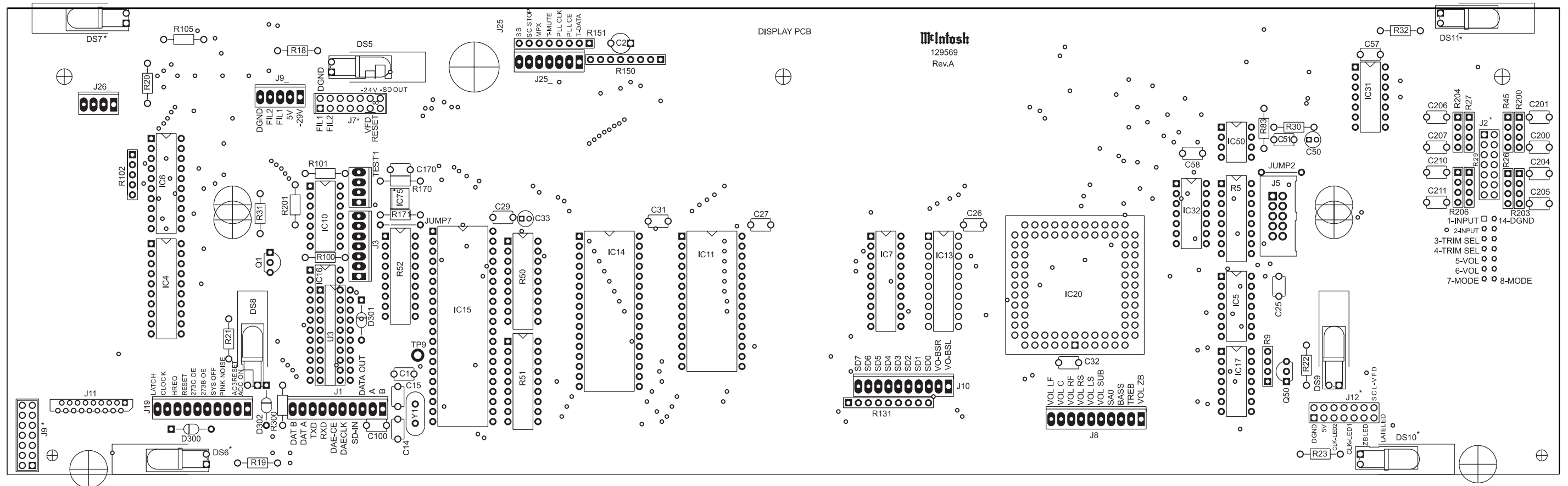

2B DISPLAY LED SECTION 050169

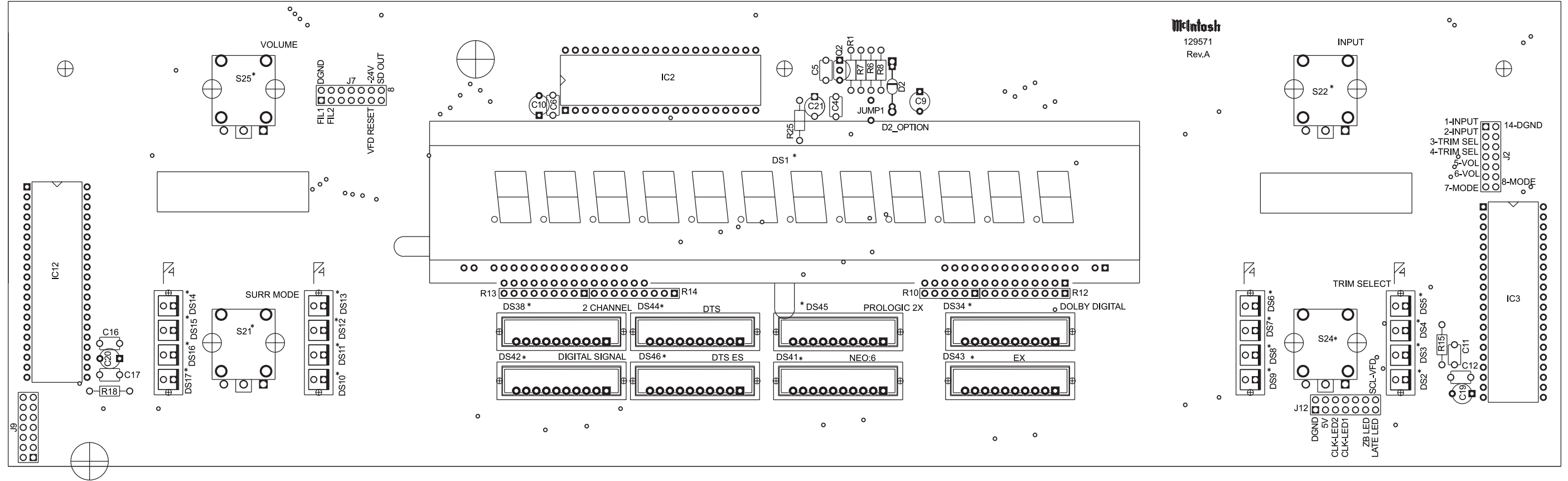

2C DISPLAY KEYBOARD SECTION 050053

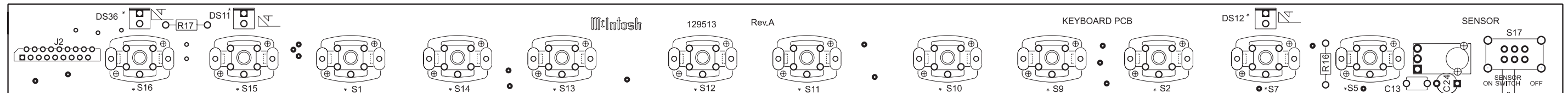

3 SURROUND 050168 SH 1 OF 6

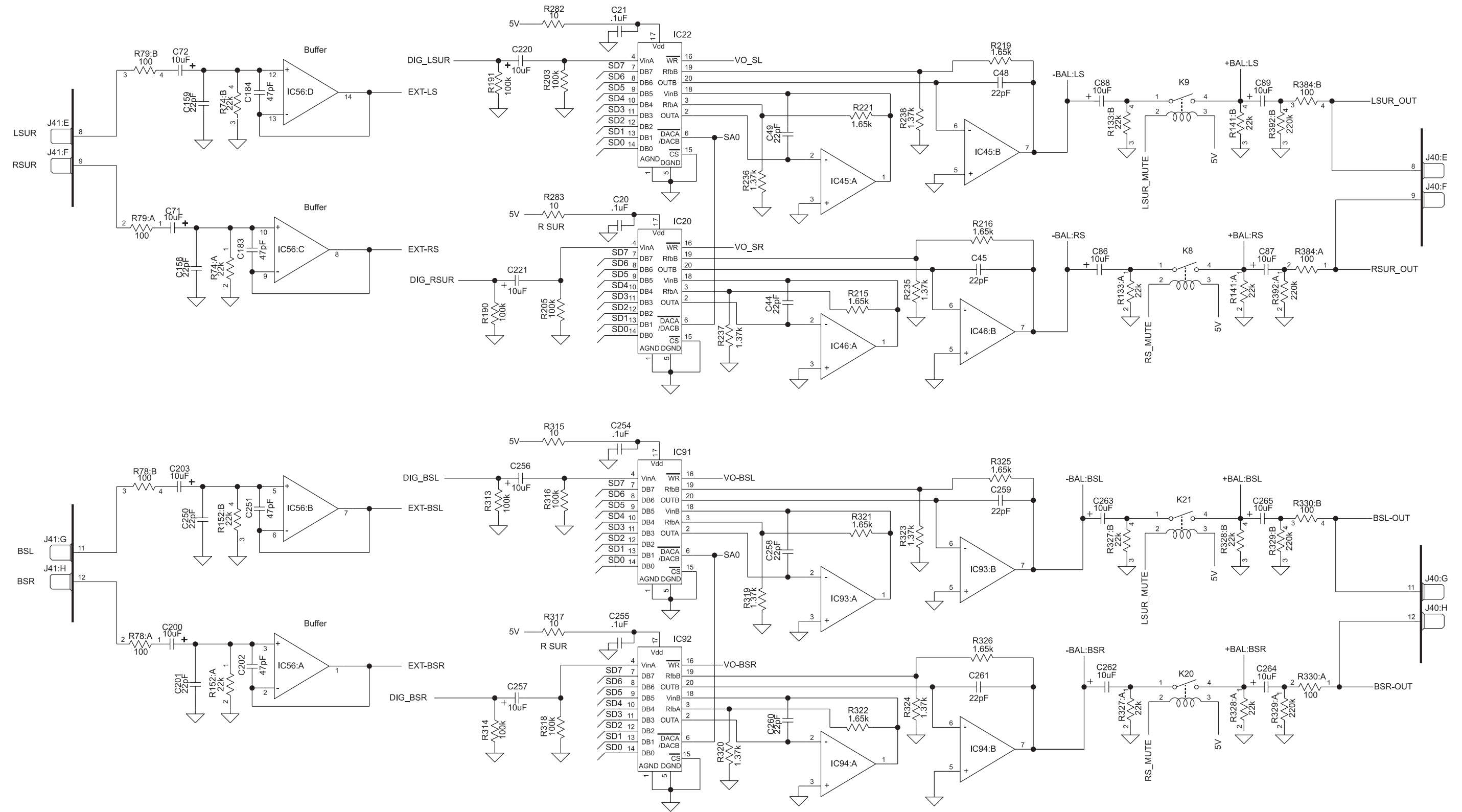

3 SURROUND 050168 SH 2 OF 6

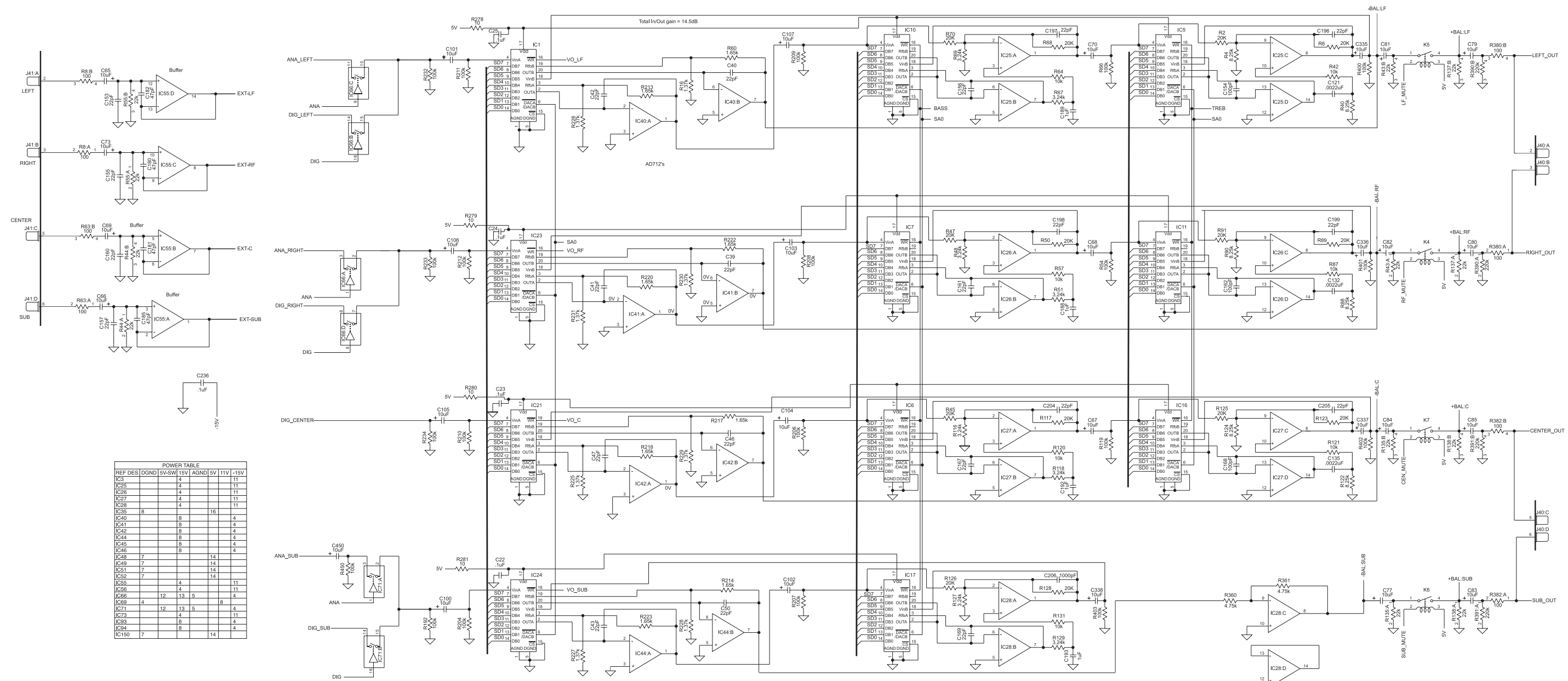

3 SURROUND 050168 SH 3 OF 6

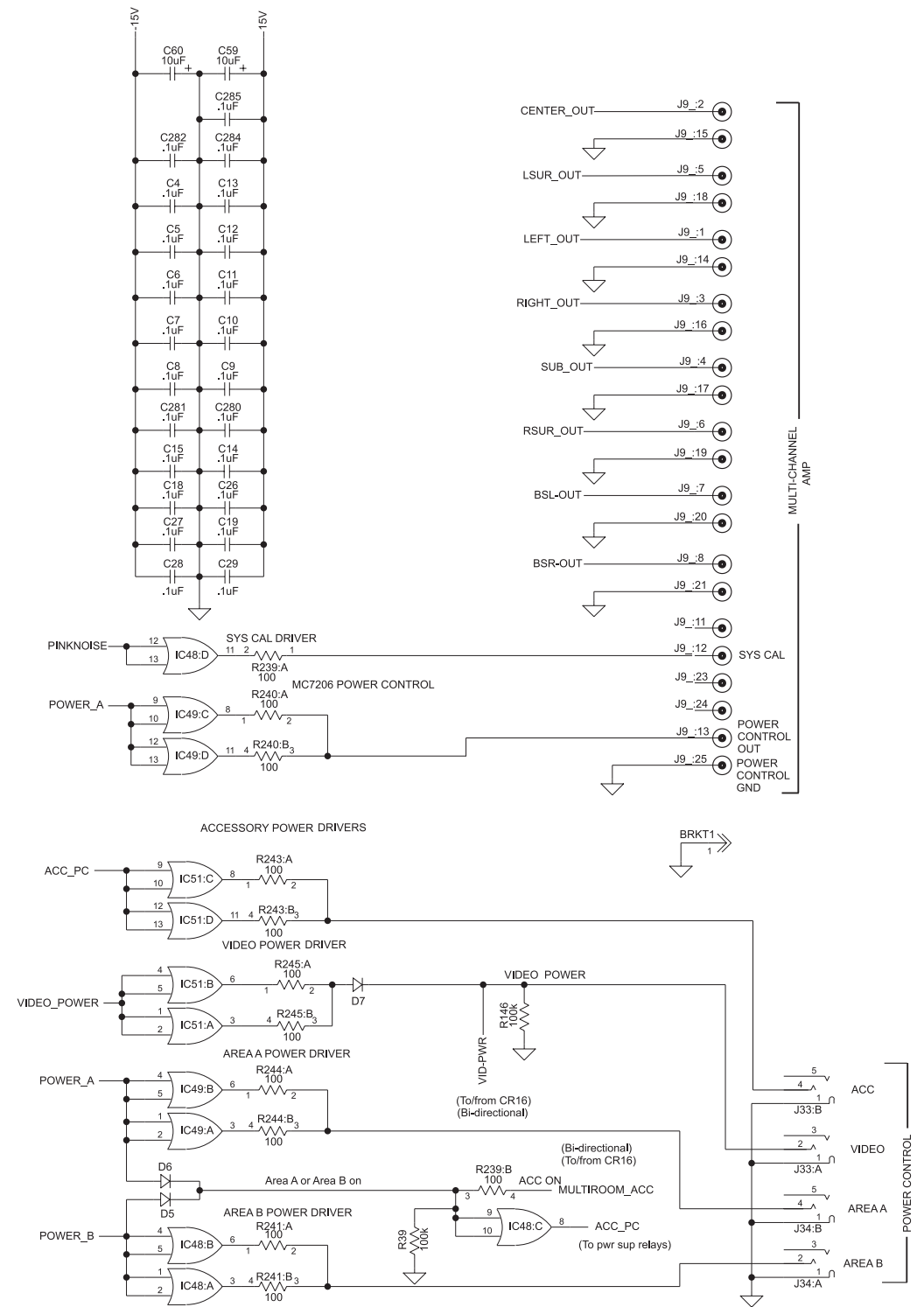
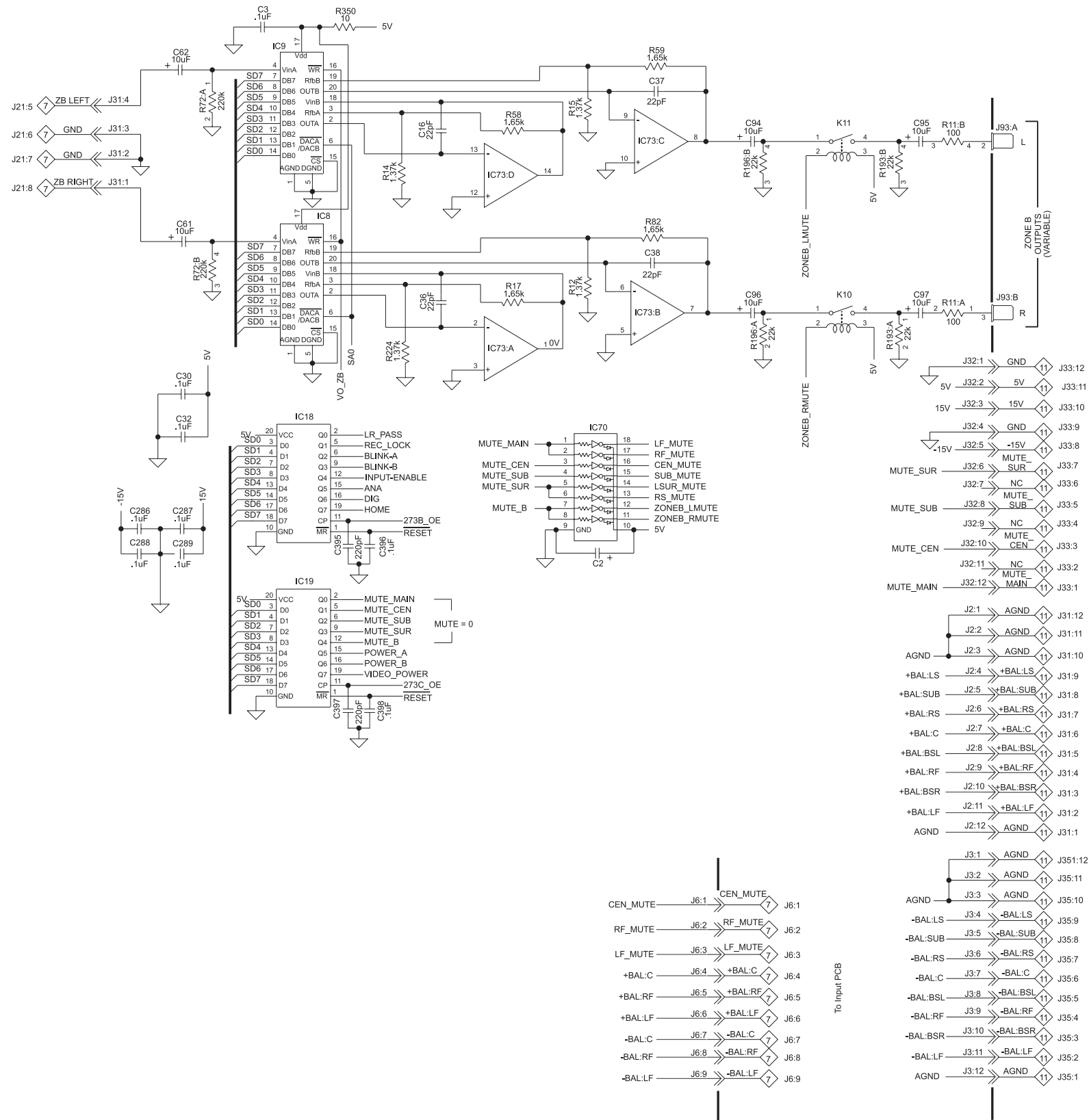

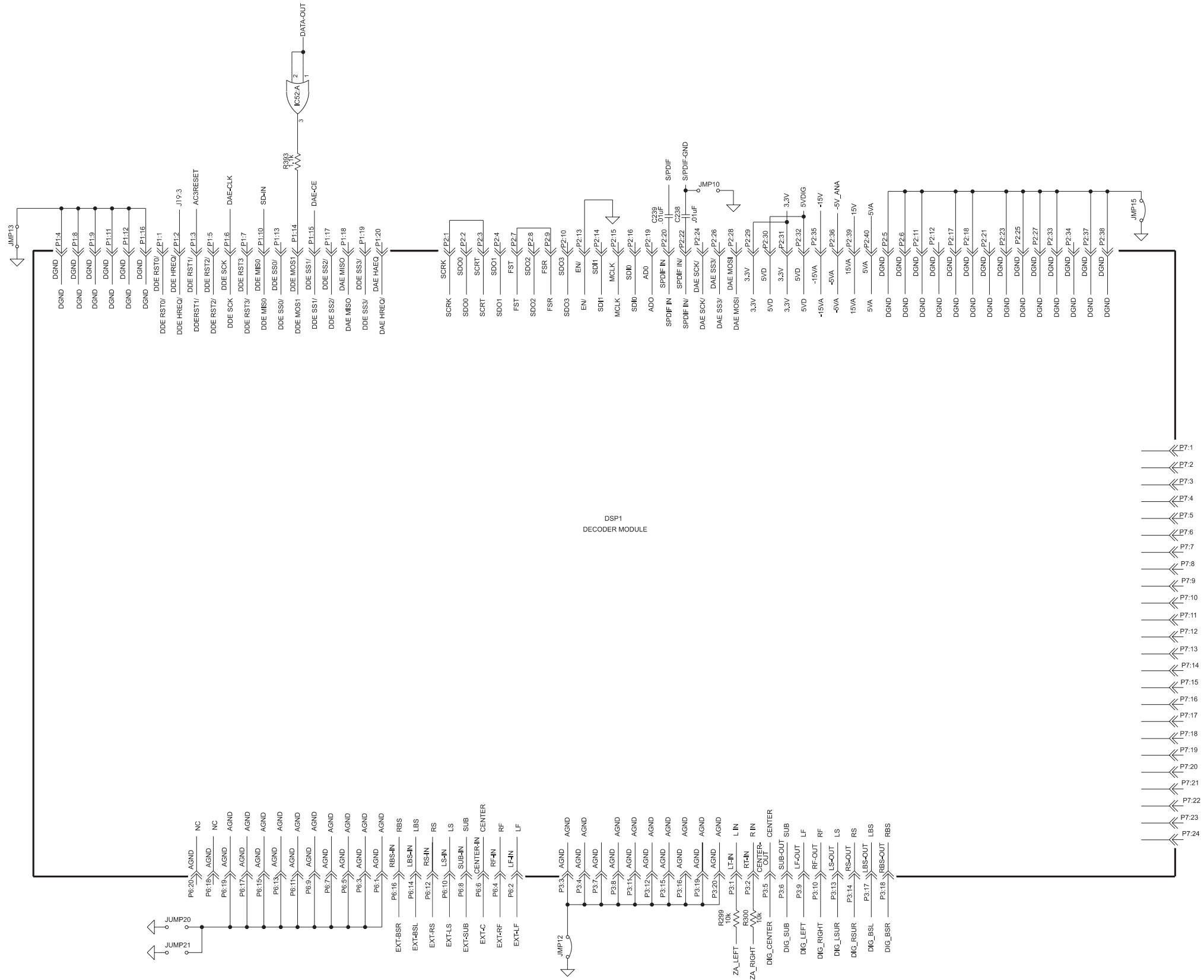

3 SURROUND 050168 SH 5 OF 6

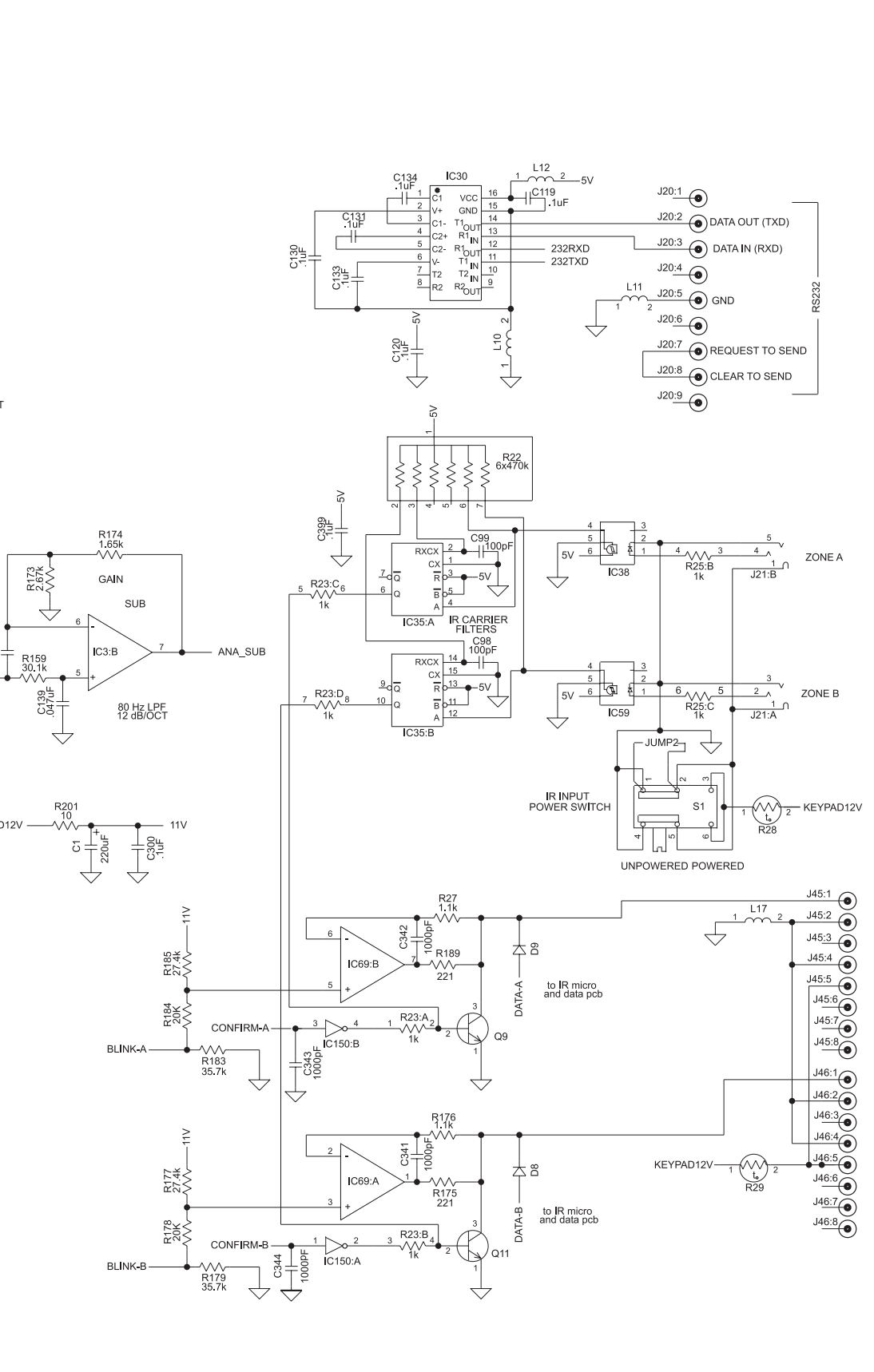
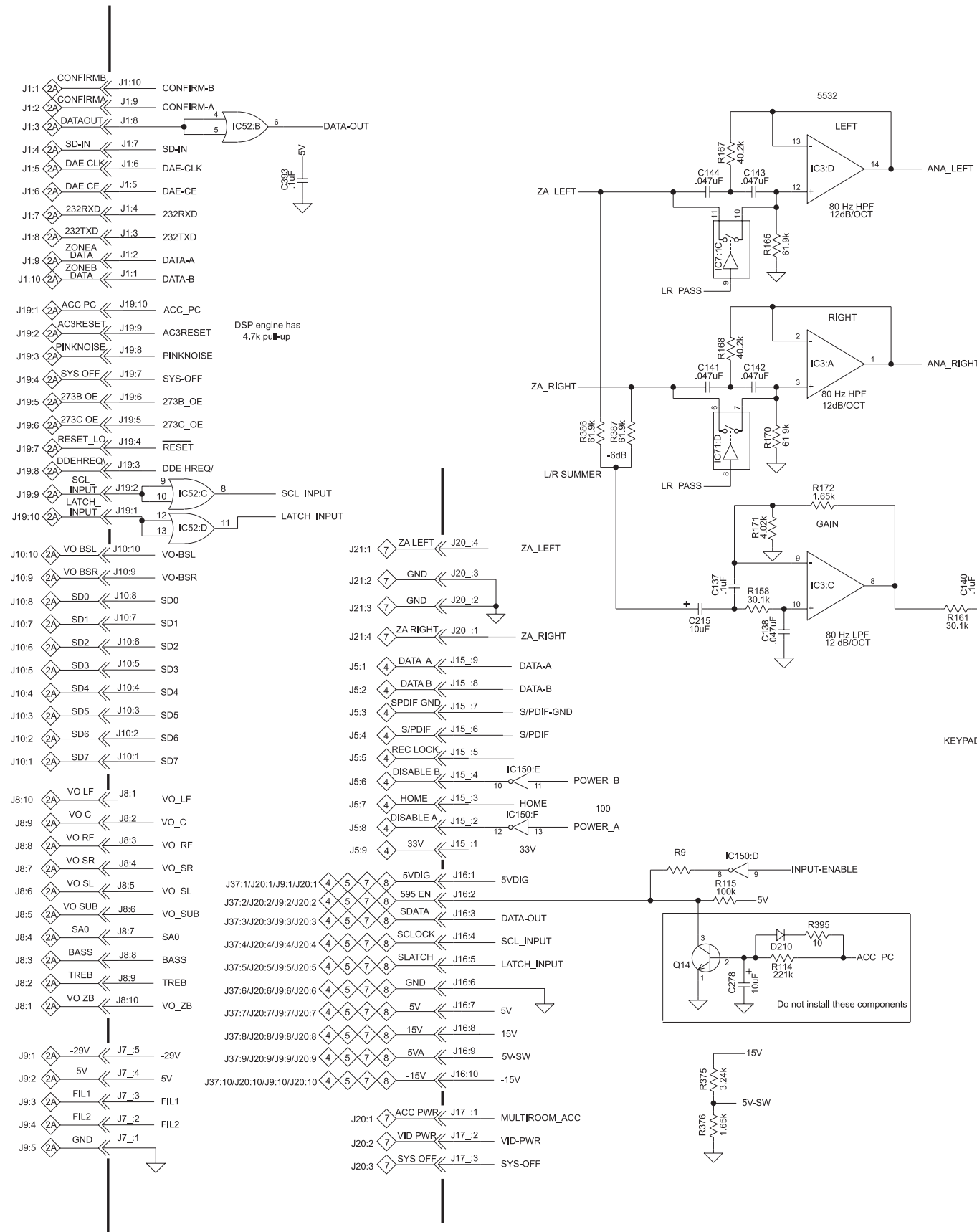

3 SURROUND 050168 SH 6 OF 6

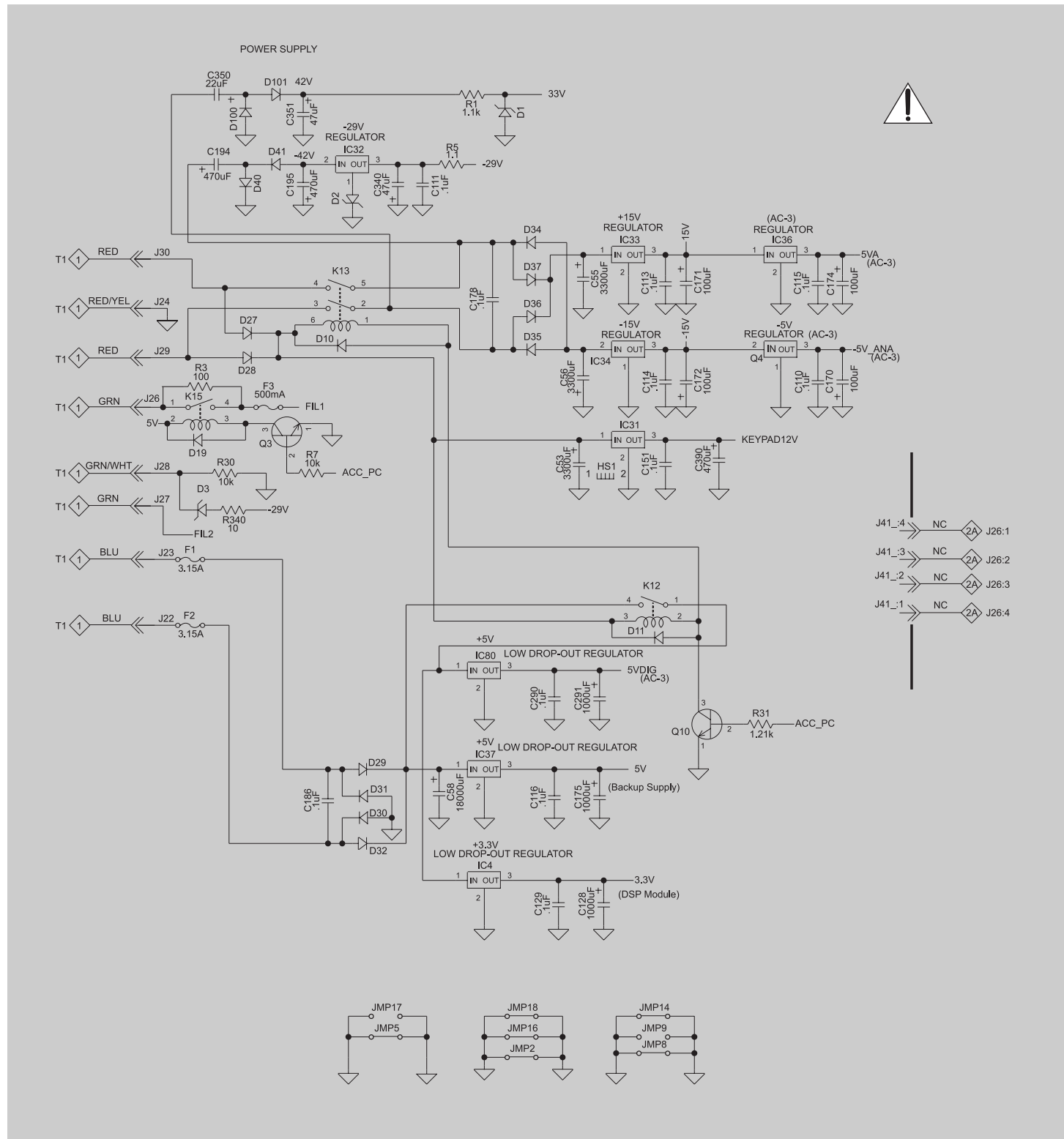

! WARNING Parts located in the shaded area have critical characteristics. Use only replacement parts recommended by the manufacturer.

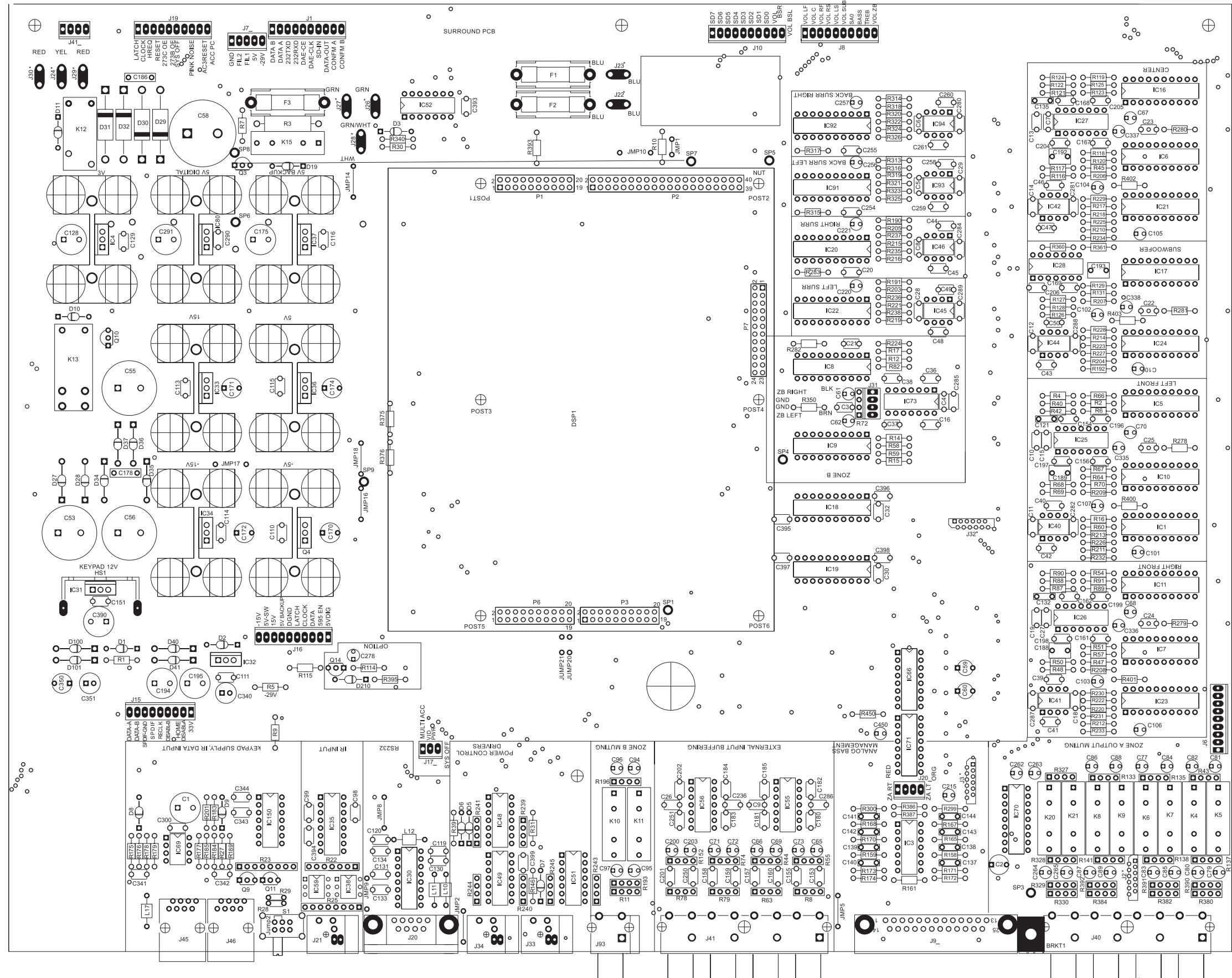

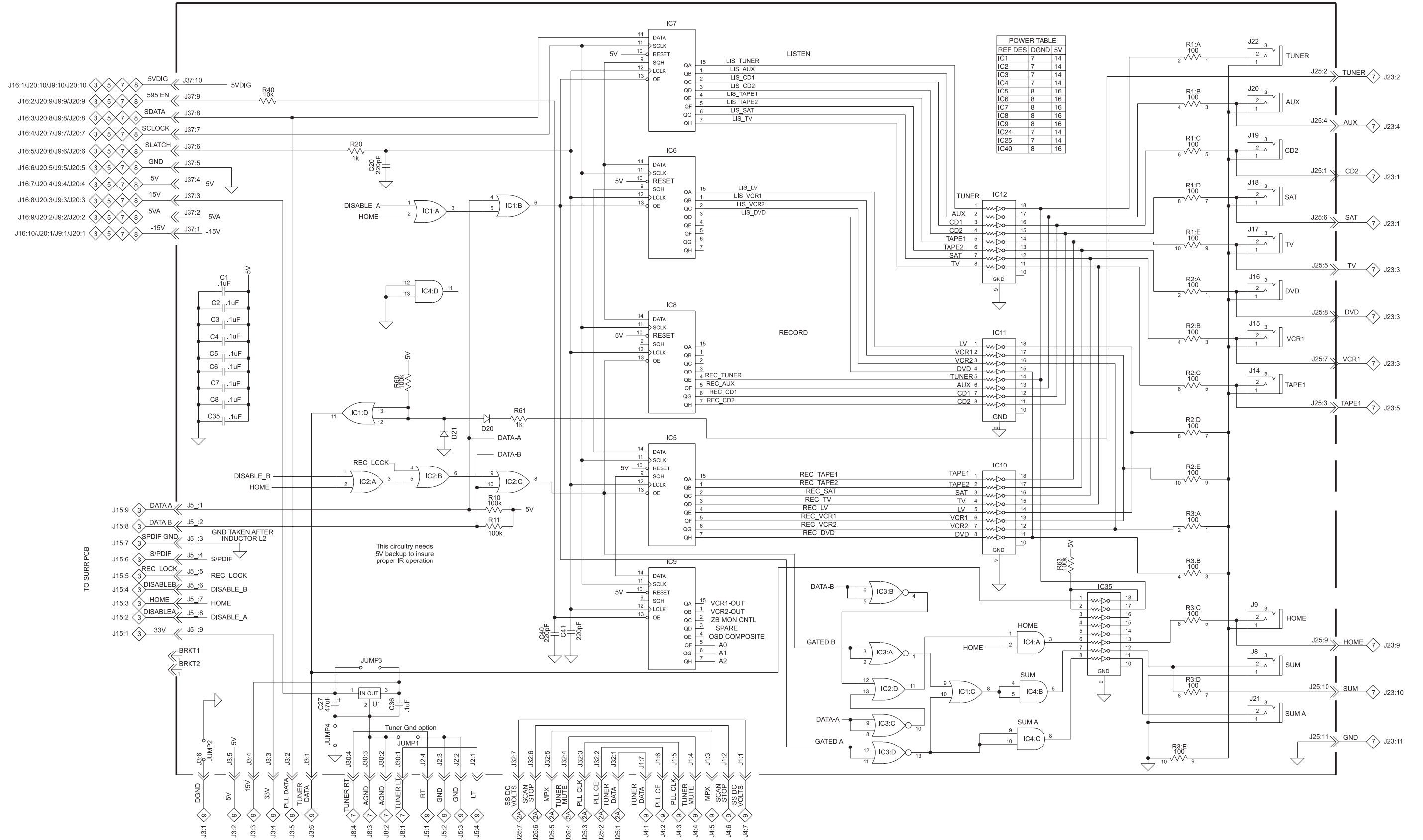

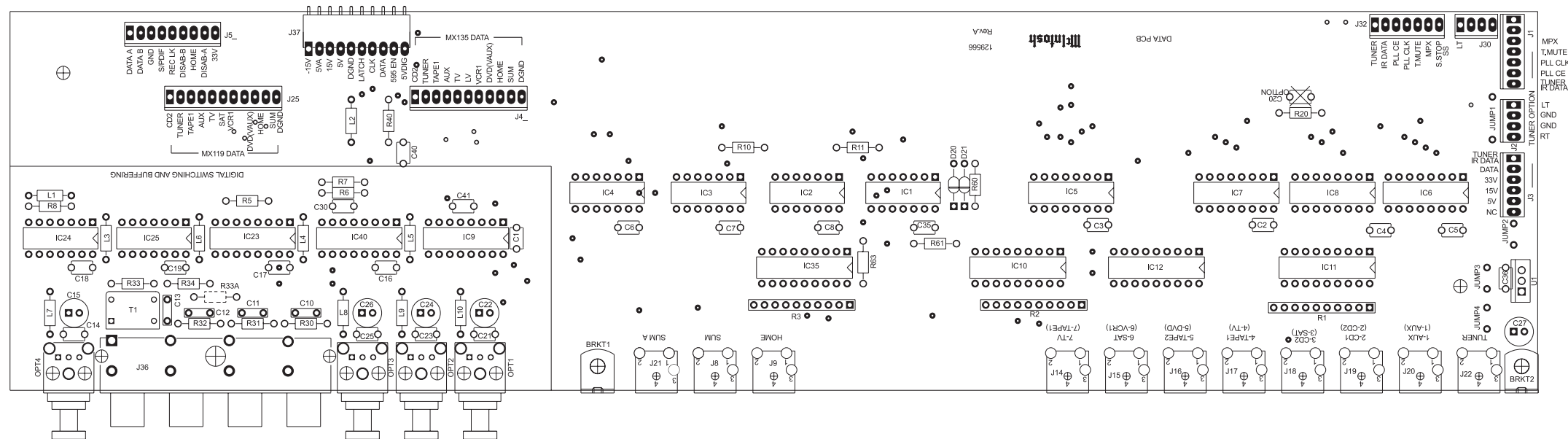
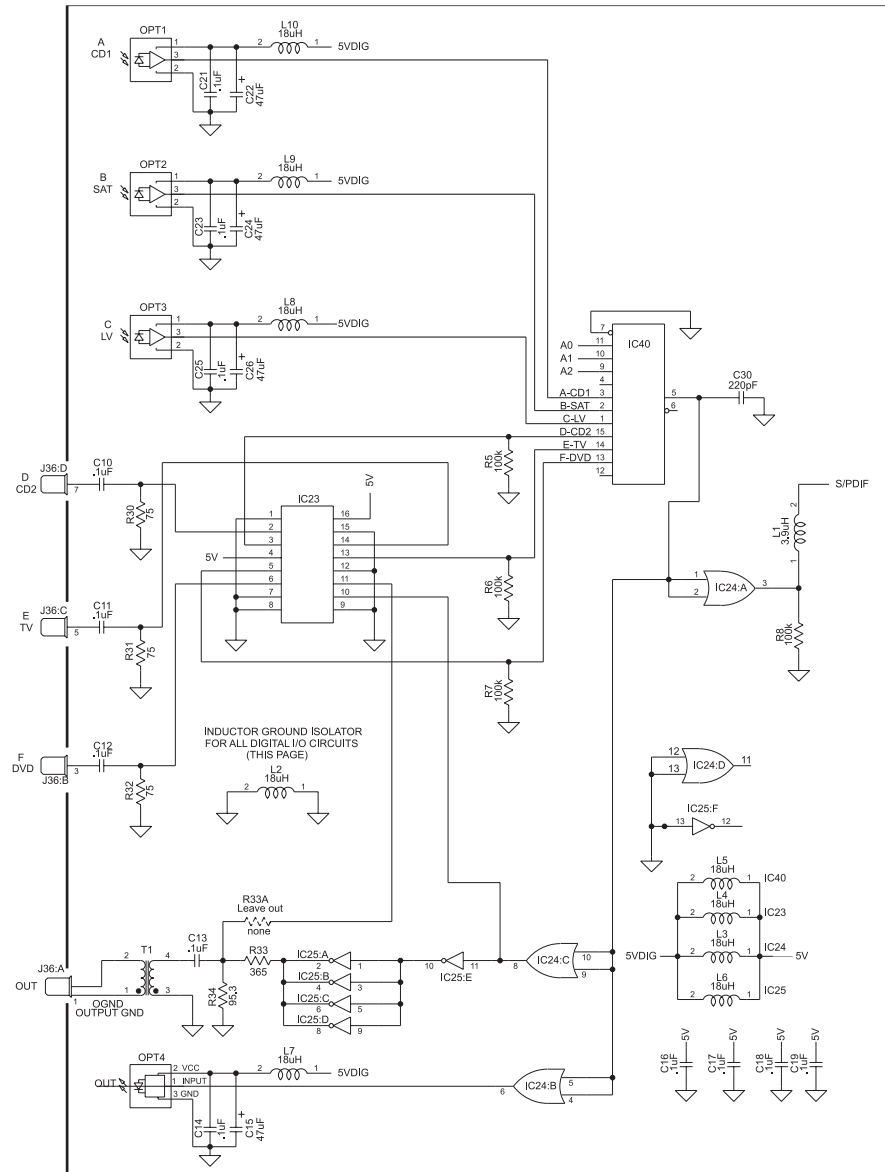

5 S-VIDEO 050166 SH 1 OF 2

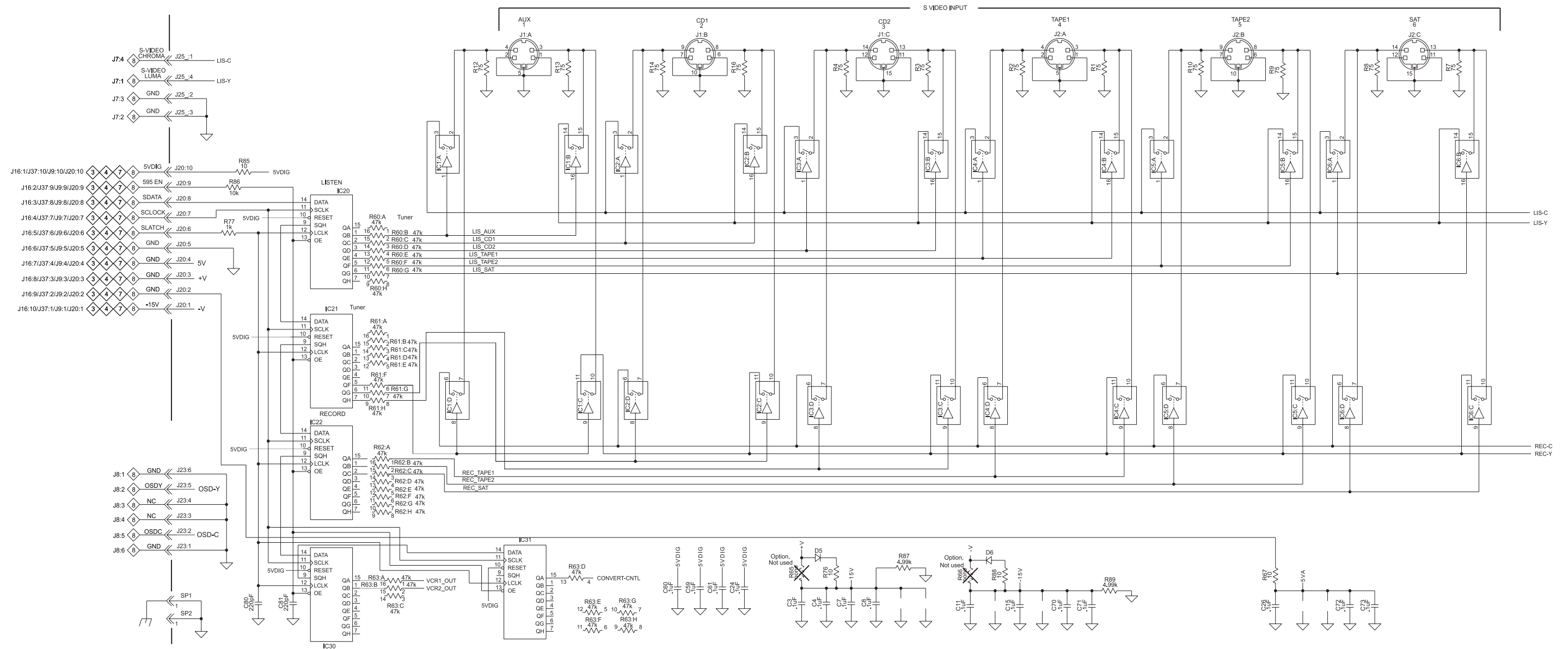

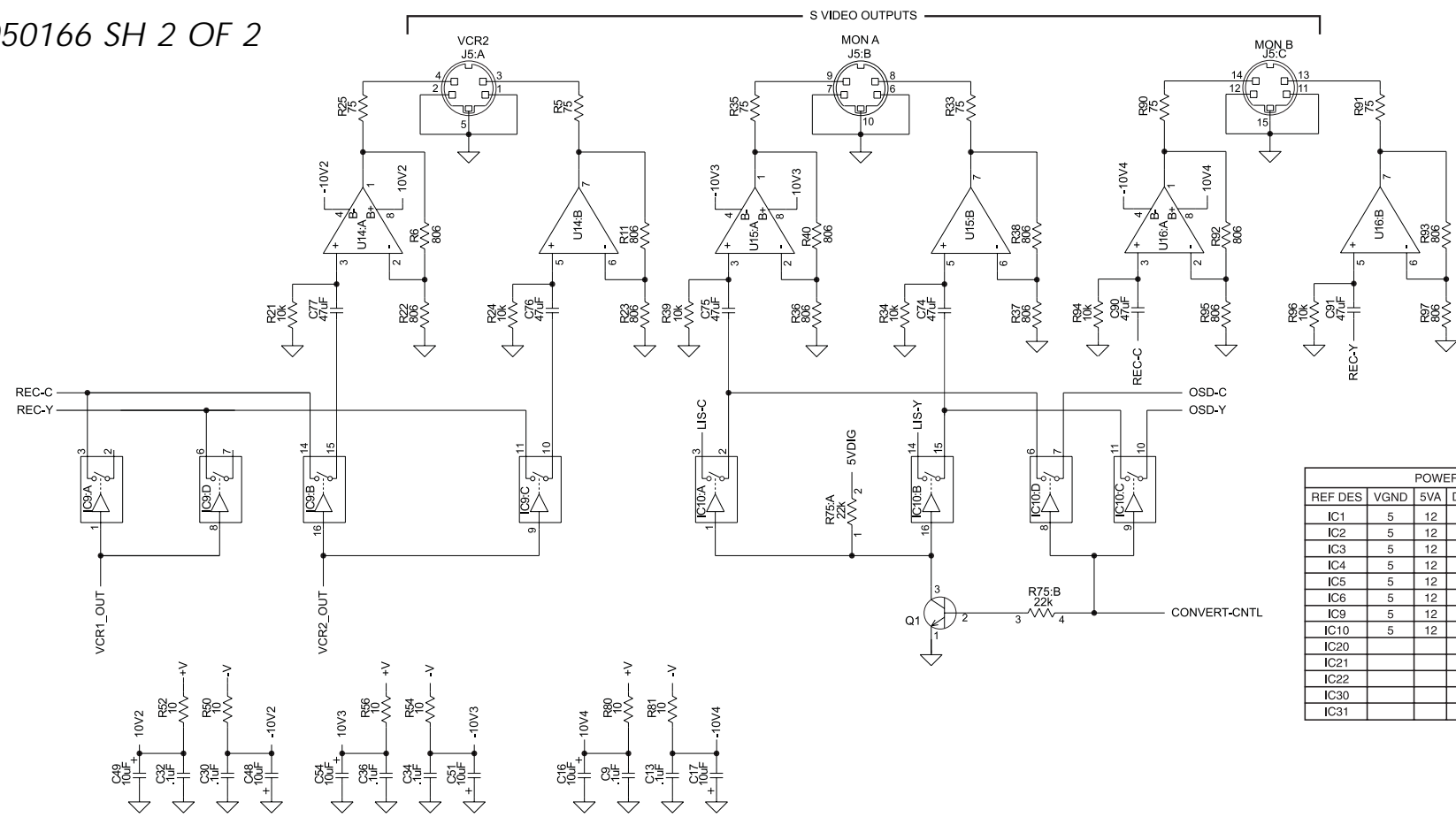

POWER TABLE					
REF DES	VGND	5VA	DGND	-15V	5VDIG
IC1	5	12		4	13
IC2	5	12		4	13
IC3	5	12		4	13
IC4	5	12		4	13
IC5	5	12		4	13
IC6	5	12		4	13
IC9	5	12		4	13
IC10	5	12		4	13
IC20			8		16
IC21			8		16
IC22			8		16
IC30			8		16
IC31			8		16

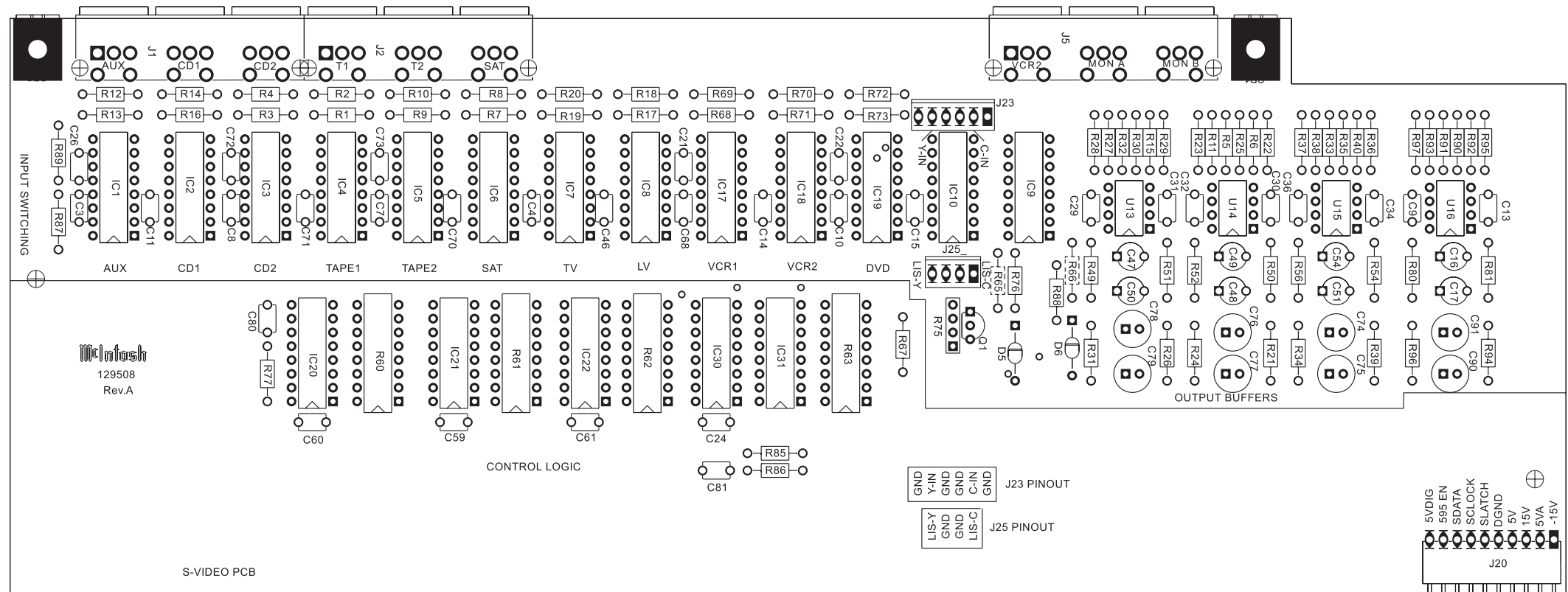

6 VIDEO 050165

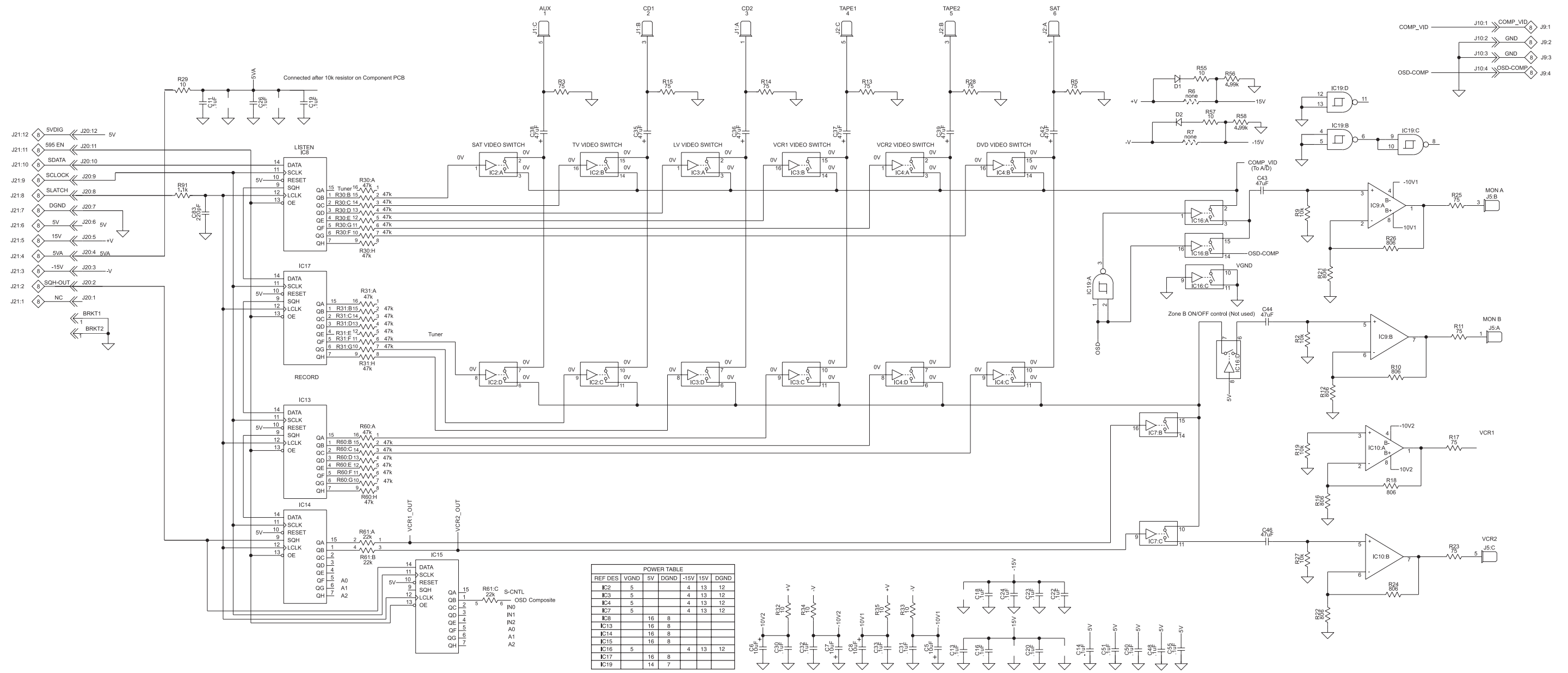

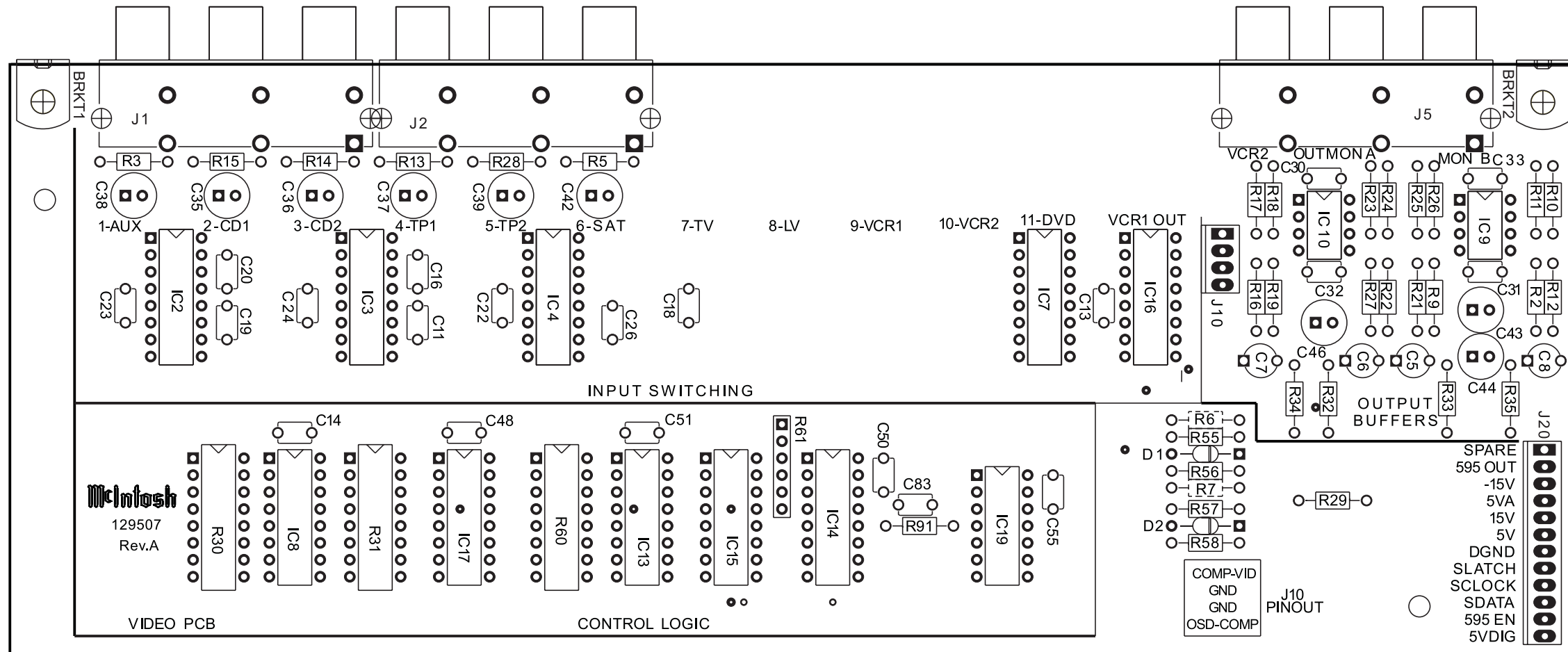

7 INPUT 050163 SH 1 OF 2

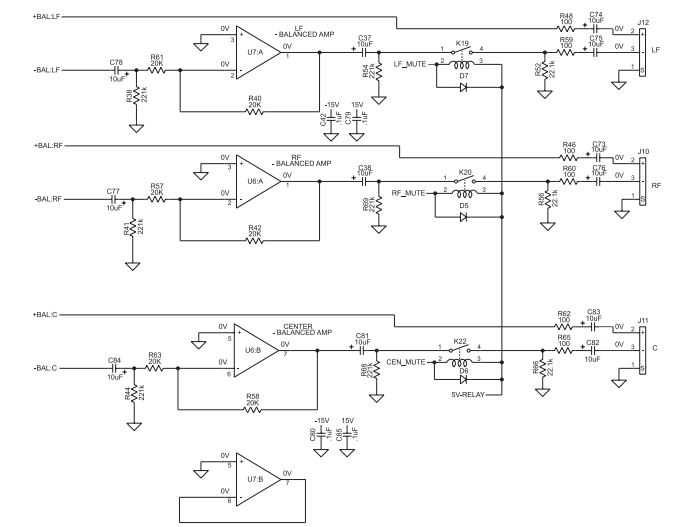
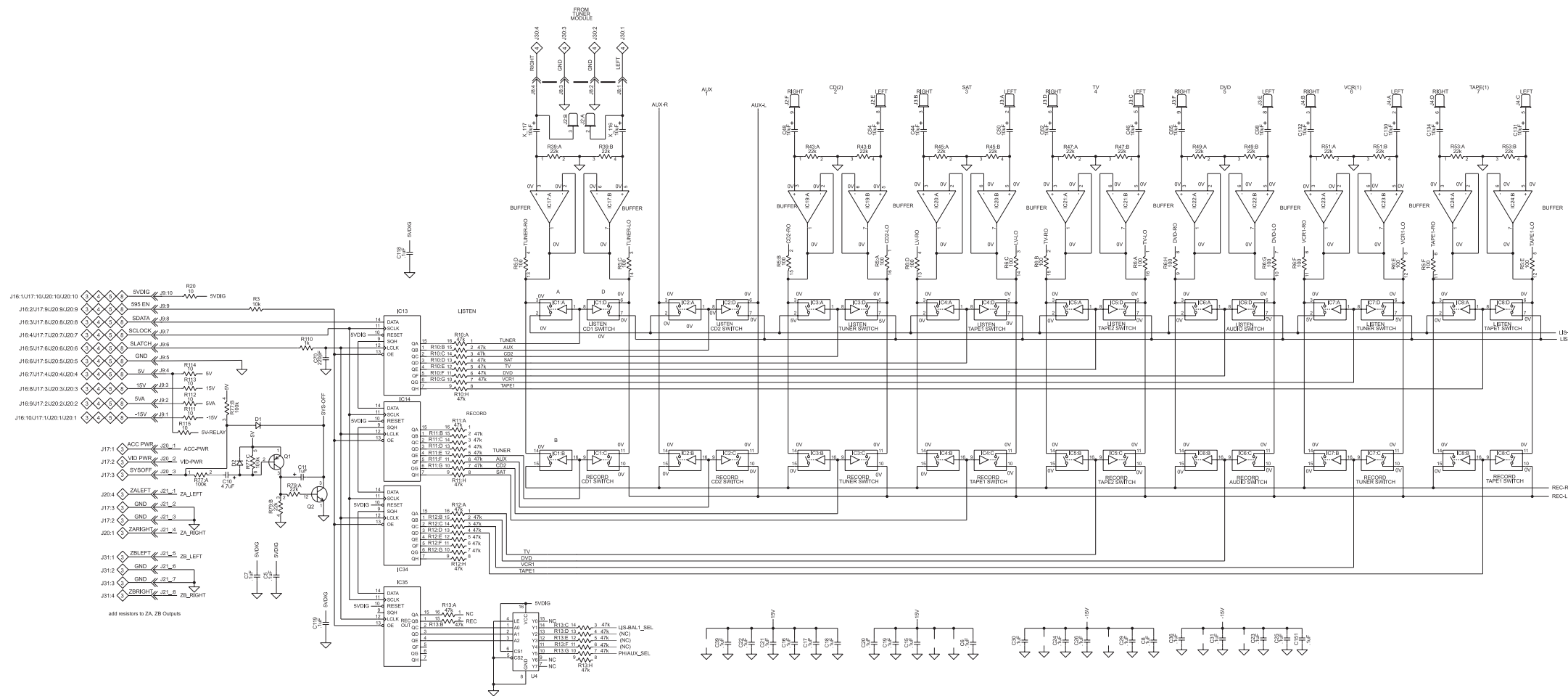

- CEN_MUTE → J6.1
- RF_MUTE → J6.2
- LF_MUTE → J6.3
- +BAL-C → J6.4
- +BAL-RF → J6.5
- +BAL-L → J6.6
- BAL-C → J6.7
- BAL-RF → J6.8
- BAL-L → J6.9

7 INPUT 050163 SH 2 OF 2

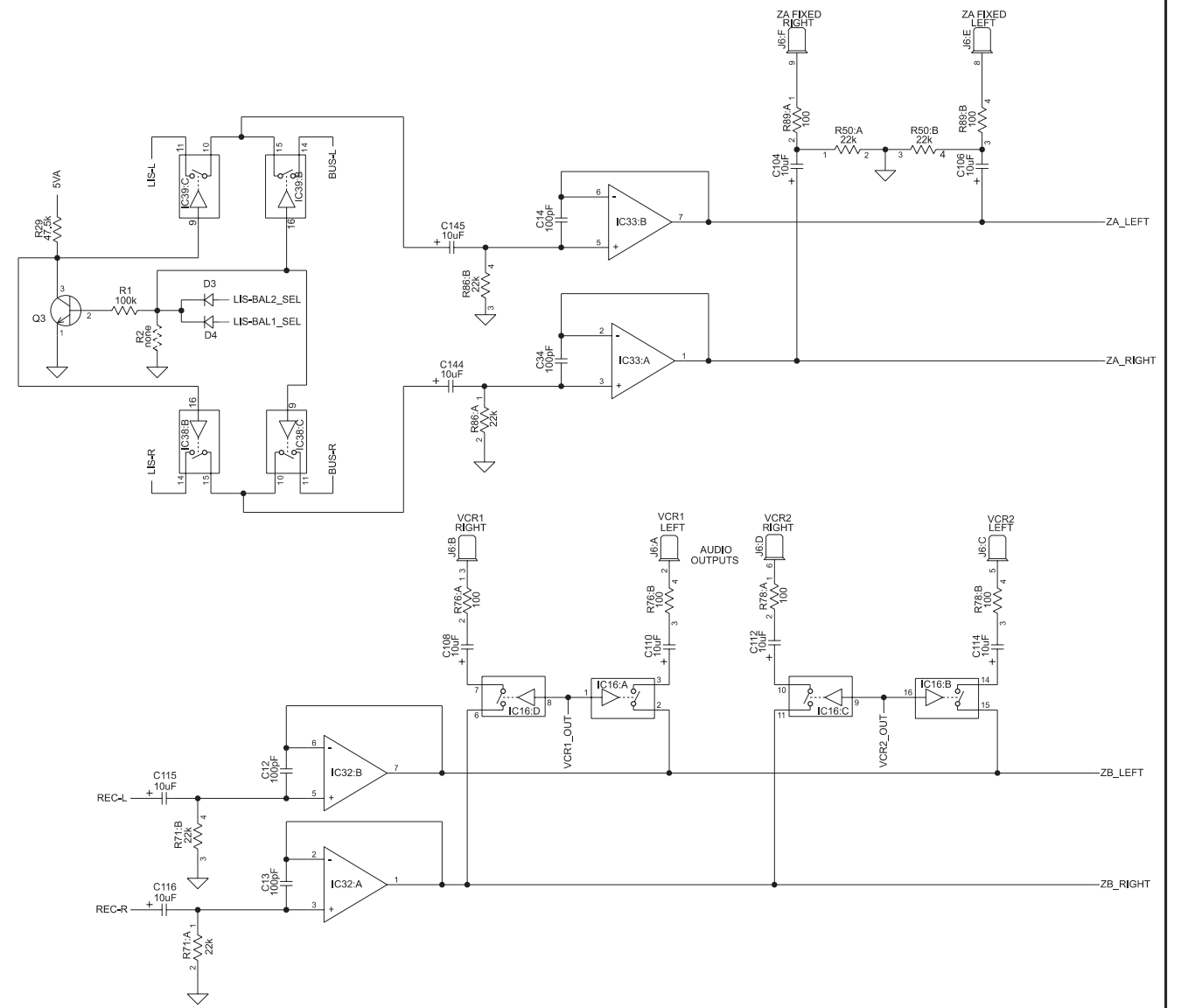
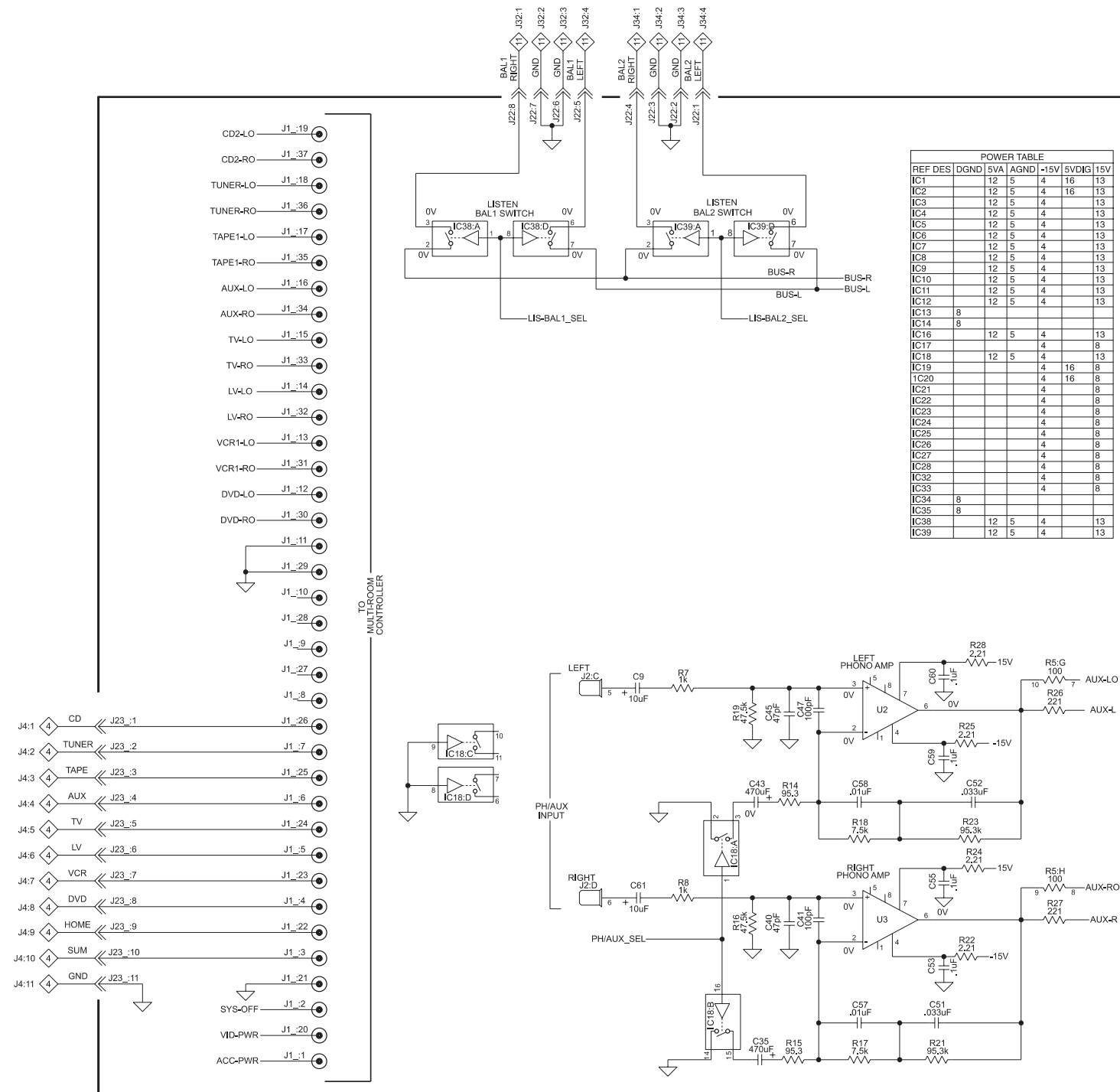

7 INPUT 050163

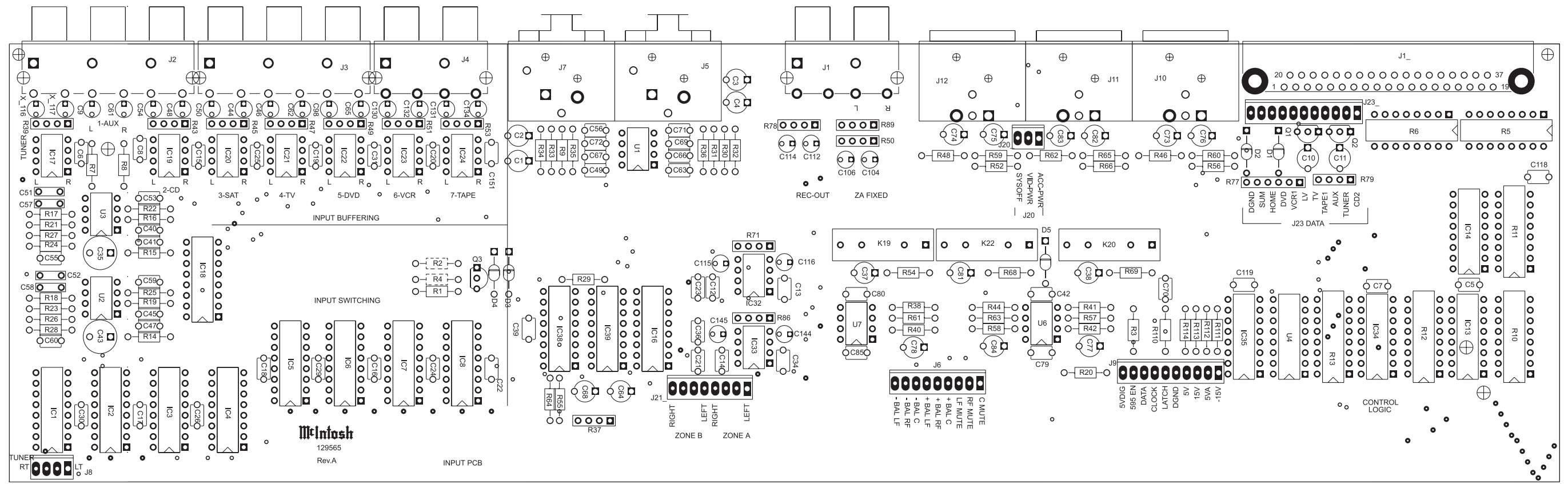

8 COMPONENT VIDEO 050180

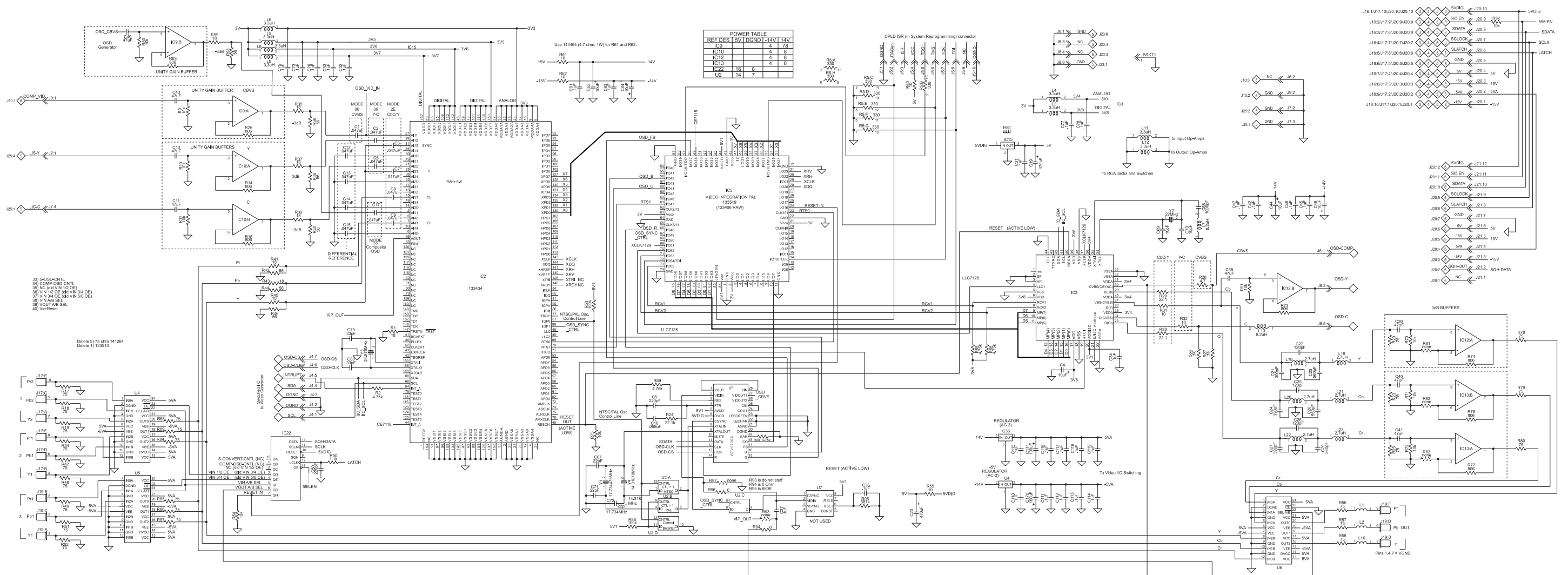

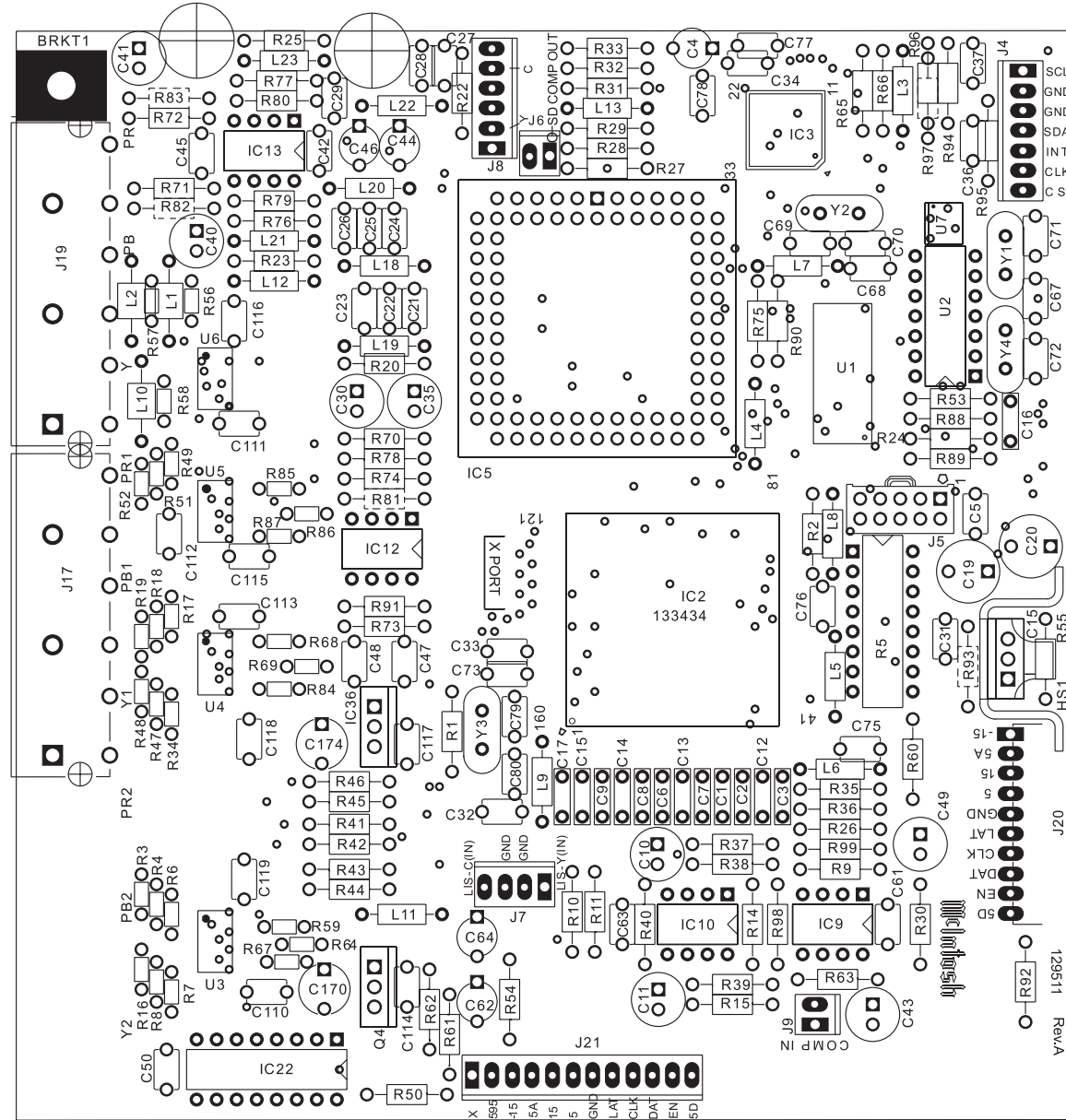

9 TUNER 049084

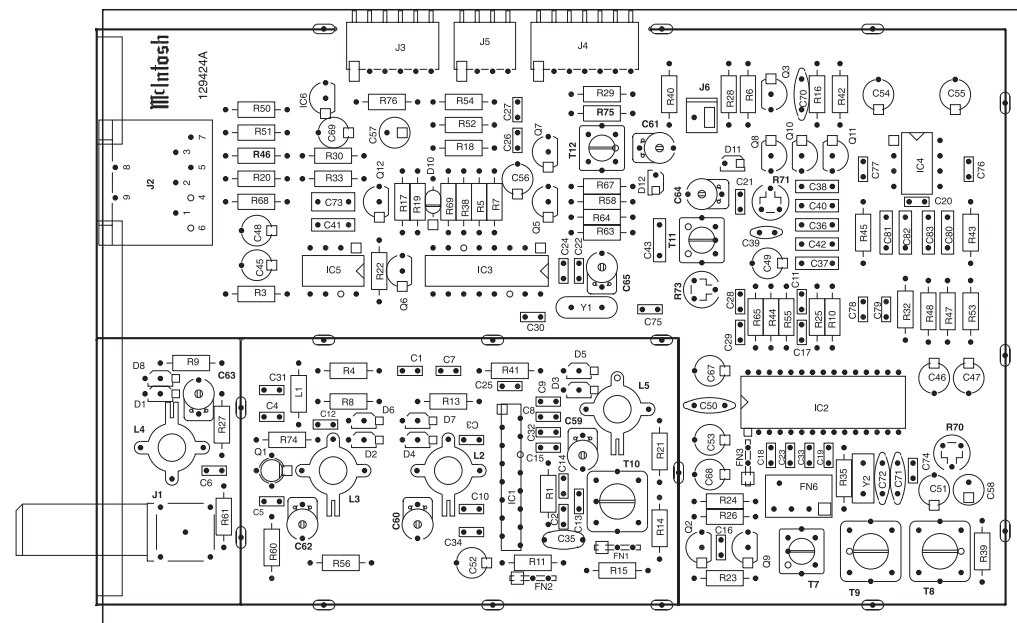
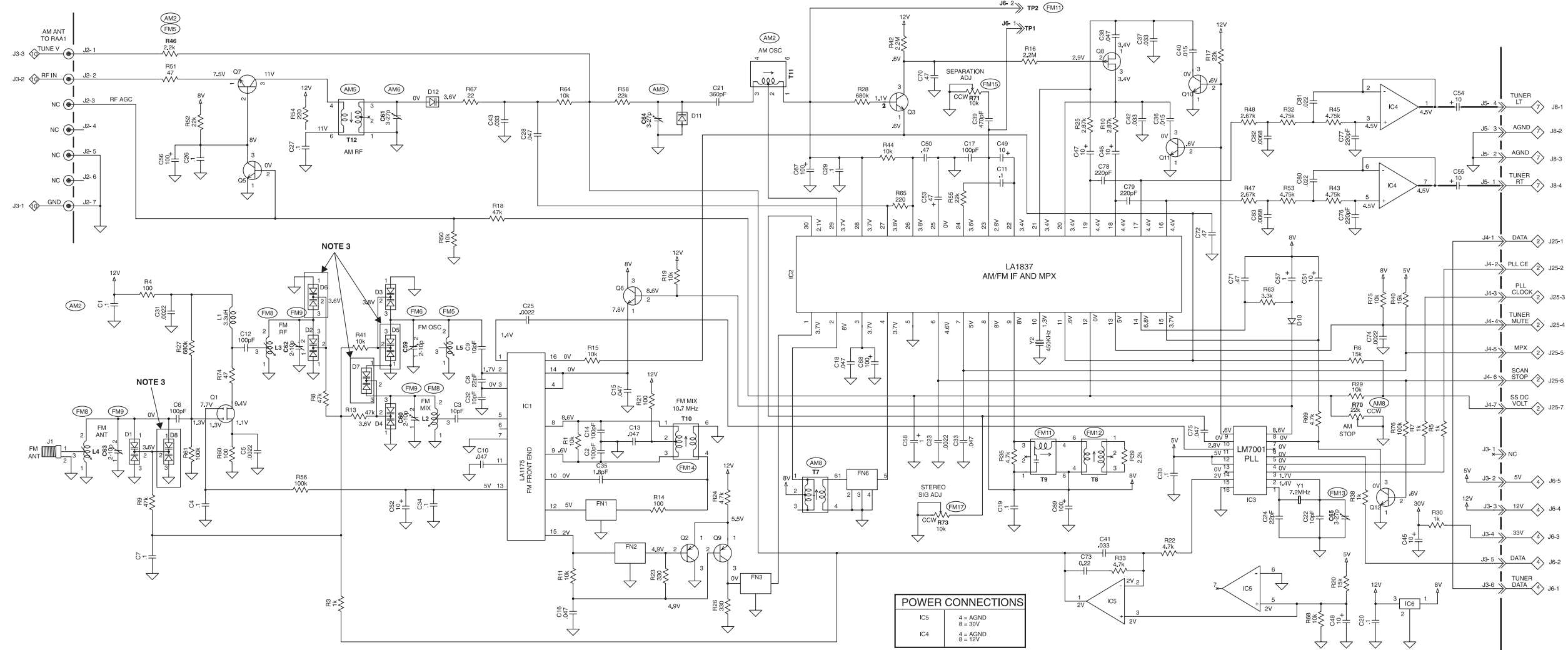

NOTE: SEE PAGE 57-58 FOR TUNER ALIGNMENT PROCEDURE.

Note: Refer to Figure 1 while reading the below procedure.

FM ALIGNMENT PROCEDURE

1. Connect an FM Signal Generator to Antenna Input.
2. Connect Distortion Analyzer to the TUNER IN/OUT RCA jacks.
3. Remove Top Cover and AM/FM TUNER Cover. Turn On the AC rocker switch. Press the red Standby button to turn the unit On.
4. Select Tuner with the Zone A selector knob. Put Tuner into FM mode and tune to 87.5MHz.
5. Adjust L5 (FM OSC Coil) for 3.5VDC at R46.
6. Tune to 108.5MHz and adjust C59 (FM OSC Trimmer Capacitor) for 24.5VDC at R46.
7. Repeat steps 4, 5 and 6 as necessary for a tuning range of 3.5VDC to 24.5VDC at R46.
8. Tune the Generator and Tuner to 90MHz and adjust Coils: L2 (FM MIX), L3 (FM RF) and L4 (FM ANT) for best sensitivity.
9. Tune the Generator and Tuner to 104MHz and adjust Trimmer Capacitors: C60 (FM MIX), C62 (FM RF) and C63 (FM ANT) for best sensitivity.
10. Repeat 8 and 9 until no improvement in sensitivity is noted.
11. Tune Tuner to 90MHz with no RF Input and adjust T9 (FM DETector Primary) for zero volts between TP1 and TP2 relative (connector J6).
12. Tune the Generator to 90MHz and adjust the RF Output to 1000uV and 100% MONO modulation at 1000Hz. Then adjust T8 (FM DETector SECondary) for lowest distortion.
13. Reduce the Generator Output to minimum and detune the Generator so the Receiver picks up only noise, then recheck the voltage between TP1 and TP2 (connector J6). Adjust T8 and C65 if needed. If it is not 0+/- 0.2VDC, repeat steps 11 and 12. If there is interference from a station on this frequency, tune the Tuner to a nearby frequency free from interference for this measurement.
14. Tune the Generator to 90MHz with a 1000uV output. Then switch the Generator to stereo (left only) and adjust T10 (FM IF Transformer) for the lowest distortion at the TUNER IN/OUT RCA jacks.
15. Switch the Analyzer to the right channel TUNER IN/OUT jack and adjust R71 (MPX SEParation Pot) for best separation (minimum output).
16. Switch the Generator to the Right Channel and the Analyzer to the Left Channel. Adjust R71 (MPX SEParation Pot) and check for best separation (minimum output).
17. Disconnect voltmeter from TP1 and TP2 (J6). Reduce the generator output to 5uV and adjust R73 (STEREO SWITCH Pot) so the MPX light (Dot next to Signal Strength number) just comes on.

AM ALIGNMENT PROCEDURE

1. Connect an AM Signal Generator to the RAA1 "EXT ANT" pin of the 5 pin connector. (Refer to Page 66.) Connect a Distortion Analyzer to the MX119 rear panel TUNER IN/OUT RCA jacks.
2. Tune to bottom of band, and adjust T11 (AM OSC Coil) for 3.0VDC at R46.
3. Tune to top of band and adjust C64 (AM OSC Trimmer Capacitor) for 26.0VDC at Connector R46.
4. Repeat steps 2 and 3 as necessary for a Tuning Voltage Range of 3.0 to 26.0VDC.
5. Tune the Generator and Tuner to 600kHz, then adjust Coils: T101 (AM ANT) and T12 (AM RF) for best sensitivity. Note: Coil T101 (AM ANT) is located on the RAA1. It is labeled "L1".
6. Tune the Generator and Tuner to 1400kHz, then adjust Trimmer Capacitors: C106 (AM ANT) and C61 (AM RF) for best sensitivity. Note: Trimmer Capacitor C106 (AM ANT) is located on the RAA1. It is labeled "C1".
7. Repeat 5 and 6 until no improvement in sensitivity is noted.

8. Note the initial position of R70, and then adjust R70 fully counter clockwise. Tune the Generator and Tuner to 1400kHz (20uV, 30% modulation), then Adjust T7 (AM IF) for maximum signal.
9. Tune the Generator and Tuner to 1400kHz (100mV, 30% modulation). Slowly adjust R70 clockwise until the MX119 front panel signal strength display reads "9".
10. Check both channels for signal to noise performance, and re-adjust R70 and as needed.

Figure 1

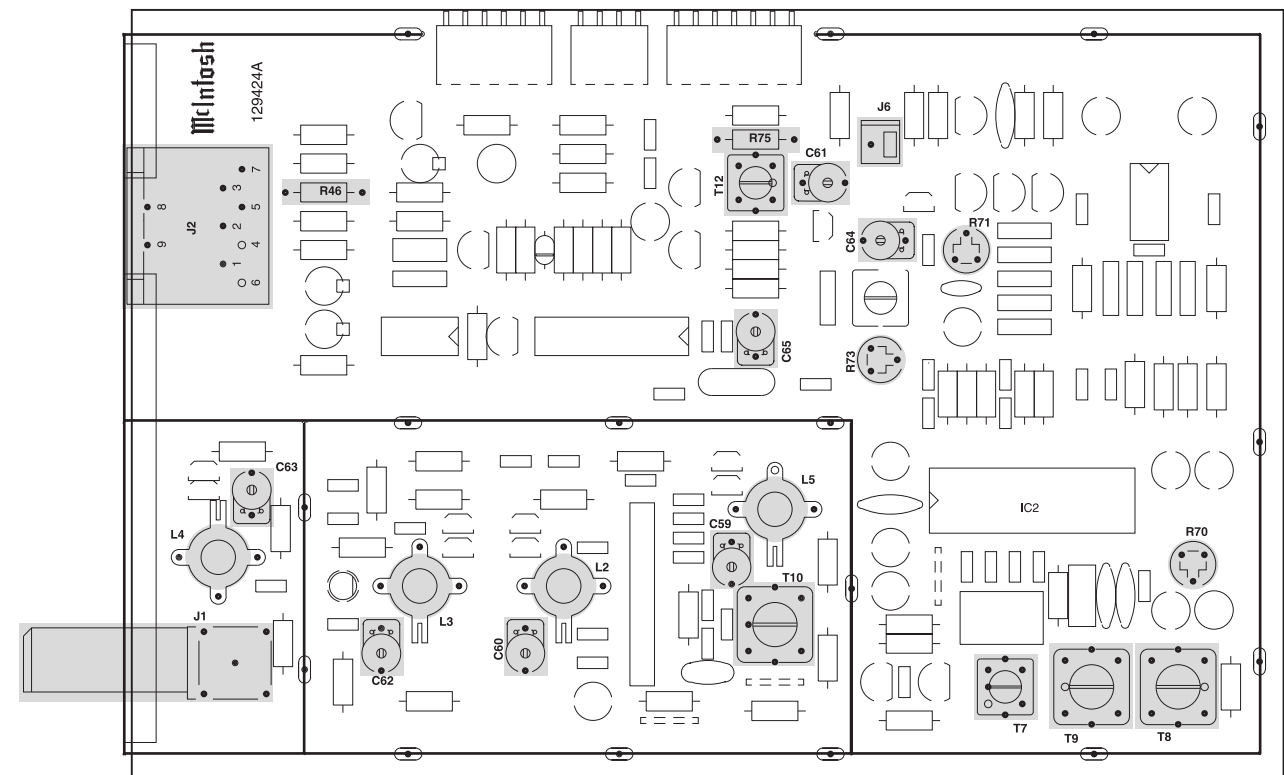

10 RAA1 SECTION

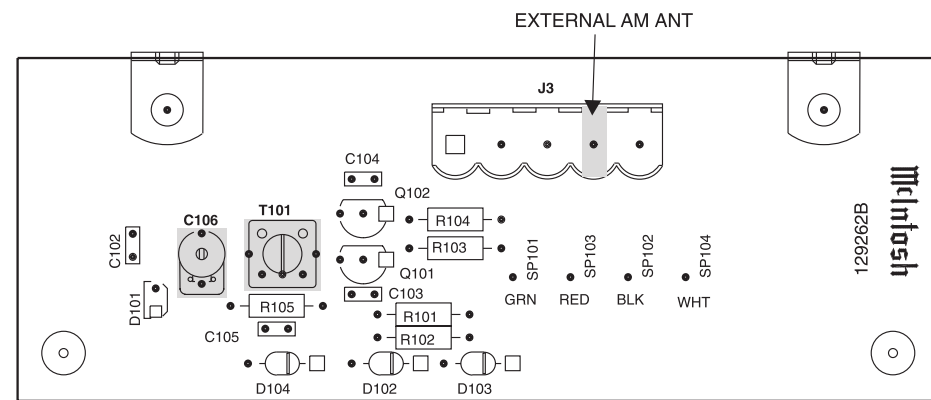
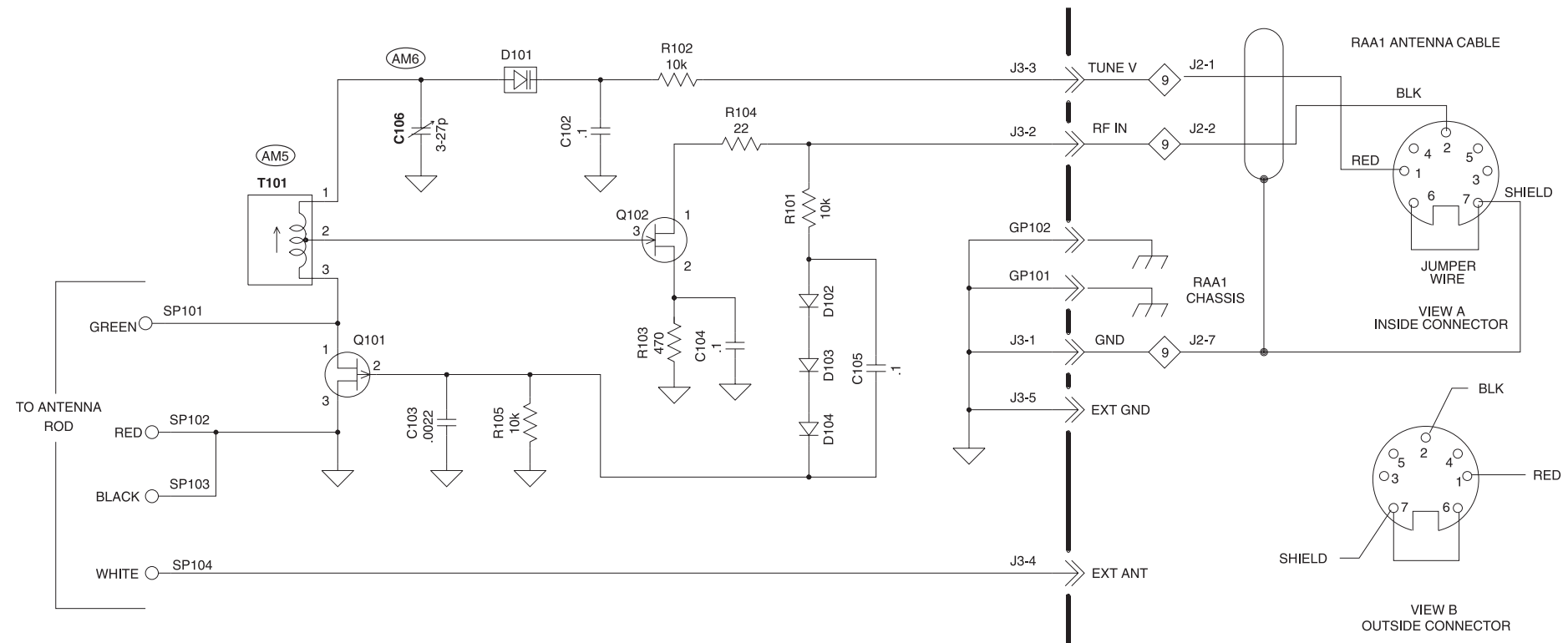

PARTS LIST

1 INTERCONNECT

Ref. No.	Description	Part No.
F1	FUSE, 800MA SLO-BLO 5 X 20	089117
TB1	AC TERMINAL BLOCK	074091
T1	POWER TRANSFORMER	159302

2A DISPLAY PCB 050167

C1	CAP MONO .01UF 50V 20% X7R	061304
C2	CAP ELECT 1UF 50V	066510
C14	CAP MONO 33PF 200V 5%	061307
C15	CAP MONO 33PF 200V 5%	061307
C25	CAP MONO .1UF 50V 20% Z5U	061305
C26	CAP MONO .1UF 50V 20% Z5U	061305
C27	CAP MONO .1UF 50V 20% Z5U	061305
C29	CAP MONO .1UF 50V 20% Z5U	061305
C31	CAP MONO .1UF 50V 20% Z5U	061305
C32	CAP MONO .1UF 50V 20% Z5U	061305
C33	CAP ELECT 10UF 16V	066382
C50	CAP ELECT 10UF 16V	066382
C51	CAP MONO .1UF 50V 20% Z5U	061305
C57	CAP MONO .1UF 50V 20% Z5U	061305
C58	CAP MONO .1UF 50V 20% Z5U	061305
C100	CAP MONO .1UF 50V 20% Z5U	061305
C170	CAP MONO 100PF 100V 10% NPO	061300
C200	CAP MONO .01UF 50V 20% X7R	061304
C201	CAP MONO .01UF 50V 20% X7R	061304
C204	CAP MONO .01UF 50V 20% X7R	061304
C205	CAP MONO .01UF 50V 20% X7R	061304
C206	CAP MONO .01UF 50V 20% X7R	061304
C207	CAP MONO .01UF 50V 20% X7R	061304
C210	CAP MONO .01UF 50V 20% X7R	061304
C211	CAP MONO .01UF 50V 20% X7R	061304
DS5	LED GRN 5MM HI-INTENSITY	058165
(DS5)	SPACER LED	112108
DS6	LED GRN 5MM HI-INTENSITY	058165
(DS6)	SPACER LED	112108
DS7	LED GRN 5MM HI-INTENSITY	058165
(DS7)	SPACER LED	112108
DS8	LED GRN 5MM HI-INTENSITY	058165
(DS8)	SPACER LED	112108
DS9	LED GRN 5MM HI-INTENSITY	058165
(DS9)	SPACER LED	112108
DS10	LED GRN 5MM HI-INTENSITY	058165
(DS10)	SPACER LED	112108
DS11	LED GRN 5MM HI-INTENSITY	058165
(DS11)	SPACER LED	112108
D300	DIODE SILICON	070047
D301	DIODE SILICON	070047
D302	DIODE SILICON	070047
IC4	IC OCTAL D-TYPE FLIP-FLOP	133348
(IC4)	SOCKET 20-PIN IC	178124
IC5	IC QUAD ANALOG SWITCH HI SPEED	133342
IC6	IC OCTAL BUFFER 3-STATE	133349
(IC6)	SOCKET 20-PIN IC	178124
IC7	IC OCTAL BUFFER 3-STATE	133349
(IC7)	SOCKET 20-PIN IC	178124
IC10	IC QUAD ANALOG SWITCH HI SPEED	133342
IC11	IC SRAM	133227
(IC11)	SOCKET IC 28 PIN	178126
IC13	IC OCT 3-STT NONINVERTING	133222
(IC13)	SOCKET 20-PIN IC	178124
IC14	IC PROG 133350 MX119	133543

Ref. No.	Description	Part No.
(IC14)	SOCKET IC 32 PIN	178165
IC15	IC MICRO ROMLESS	133386
(IC15)	SOCKET IC 40-PIN	178133
IC17	IC QUAD ANALOG SWITCH HI SPEED	133342
IC20	IC: PROG CONTROL CPLD 133406	133548
(IC20)	SOCKET IC PLCC 84 PIN	178174
IC31	IC NAND SCHMIT 2-IN X 4	133192
IC32	IC NAND SCHMIT 2-IN X 4	133192
IC50	IC 8 BIT A/D SERIAL OUTPUT	133366
IC75	IC CPU SUPERVISOR	133424
J1	CONN MALE 10 POS	117219
J2	SOCKET STRIP 14 PIN .025 SQ	117644
J3	CONN MALE 7 PIN	117217
J5	CONN 10 PIN BOXED HEADER	117795
J7	SOCKET STRIP 14 PIN .025 SQ	117644
J8	CONN MALE 10 POS	117219
J9	SOCKET STRIP 14 PIN .025 SQ	117644
(J9)	CONN MALE 5 PIN 0.1 POST ASSY	117216
J10	CONN MALE 10 POS	117219
J11	CONN FFC 18PIN	117765
J12	SOCKET STRIP 14 PIN .025 SQ	117644
J19	CONN MALE 10 POS	117219
J25	CONN MALE 7 PIN	117217
J26	CONN 4 PIN	117215
PCB1	PC BD DISPLAY	129569
Q1	TRANSISTOR NPN SILICON	132171
Q50	TRANSISTOR NPN 2K/REEL	132223
R5	RES NETWORK 8X330 ISO	144263
R9	RES NET 2 X 22K ISOLATED	144366
R18	RES MF 100 OHM 1% 1/4W	144196
R19	RES MF 47.5 OHM 1% 1/4W	144442
R20	RES MF 100 OHM 1% 1/4W	144196
R21	RES MF 182 OHM 1/4W 1%	144273
R22	RES MF 182 OHM 1/4W 1%	144273
R23	RES MF 47.5 OHM 1% 1/4W	144442
R26	RES NET 2 X 22K ISOLATED	144366
R27	RES NET 2 X 22K ISOLATED	144366
R29	RES NET 2 X 22K ISOLATED	144366
R30	RES MF 10 OHM 1% 1/4W	144157
R31	RES MF 4.99K 1% 1/4W	144098
R32	RES MF 100 OHM 1% 1/4W	144196
R45	RES NET 2 X 22K ISOLATED	144366
R50	RES NETWORK 9X1K ISO	144280
R51	RES NETWORK 9X1K ISO	144280
R52	RES NETWORK 9X1K ISO	144280
R83	RES FP 10 OHM 5% 1/4W	137025
R100	RES MF 10K 1% 1/4W	144053
R101	RES MF 10K 1% 1/4W	144053
R102	RES NETWORK 4 X 22K BUS	144234
R105	RES MF 10K 1% 1/4W	144053
R131	RES NET 10K X8 RES BUSSED	144253
R150	RES NETWORK 4X1K ISO	144276
R151	RES NETWORK 4X1K ISO	144276
R170	RES MF 4.99K 1% 1/4W	144098
R171	RES MF 4.99K 1% 1/4W	144098
R200	RES NET 2 X 22K ISOLATED	144366
R201	RES MF 47.5K 1% 1/4W	144108
R203	RES NET 2 X 22K ISOLATED	144366
R204	RES NET 2 X 22K ISOLATED	144366
R206	RES NET 2 X 22K ISOLATED	144366

PARTS LIST Con't

DISPLAY PCB 050167 (Cont'd.)

Ref. No.	Description	Part No.
R300	RES MF 47.5K 1% 1/4W	144108
U3	IC:PROGRAMMED133336, IR MICRO	133545
(U3)	SOCKET 20-PIN IC	178124
Y1	CRYSTAL 11.0592MHZ	180051

2B LED PCB 050169

C4	CAP MONO .1UF 50V 20% Z5U	061305
C5	CAP MONO .1UF 50V 20% Z5U	061305
C6	CAP MONO .1UF 50V 20% Z5U	061305
C10	CAP ELECT 47UF 35V	066446
C11	CAP MONO 1000PF 50V 10% NPO	061303
C12	CAP MONO .1UF 50V 20% Z5U	061305
C16	CAP MONO .1UF 50V 20% Z5U	061305
C17	CAP MONO 1000PF 50V 10% NPO	061303
C19	CAP ELECT 47UF 35V	066446
C20	CAP ELECT 47UF 35V	066446
C21	CAP ELECT 10UF 50V	066445
DS1	DISPLAY VFD 12 CHARACTER	058182
DS2	LED SQUARE RED	058109
DS3	LED SQUARE RED	058109
DS4	LED SQUARE RED	058109
DS5	LED SQUARE RED	058109
DS6	LED SQUARE RED	058109
DS7	LED SQUARE RED	058109
DS8	LED SQUARE RED	058109
DS9	LED SQUARE RED	058109
DS10	LED SQUARE RED	058109
DS11	LED SQUARE RED	058109
DS12	LED SQUARE RED	058109
DS13	LED SQUARE RED	058109
DS14	LED SQUARE RED	058109
DS15	LED SQUARE RED	058109
DS16	LED SQUARE RED	058109
DS17	LED SQUARE RED	058109
DS34	LED ARRAY(5) YELLOW RECTANGLE	058127
(DS34)	CONN 10 PIN	117876
DS38	LED ARRAY(5) YELLOW RECTANGLE	058127
(DS38)	CONN 10 PIN	117876
DS41	LED ARRAY(5) YELLOW RECTANGLE	058127
(DS41)	CONN 10 PIN	117876
DS42	LED ARRAY(5) YELLOW RECTANGLE	058127
(DS42)	CONN 10 PIN	117876
DS43	LED ARRAY(5) YELLOW RECTANGLE	058127
(DS43)	CONN 10 PIN	117876
DS44	LED ARRAY(5) YELLOW RECTANGLE	058127
(DS44)	CONN 10 PIN	117876
DS45	LED ARRAY(5) YELLOW RECTANGLE	058127
(DS45)	CONN 10 PIN	117876
DS46	LED ARRAY(5) YELLOW RECTANGLE	058127
(DS46)	CONN 10 PIN	117876
IC2	IC VFD DRIVER	133549
(IC2)	SOCKET IC 40-PIN	178133
IC3	IC DISPLAY DRIVER 4 DIGIT LED	133268
(IC3)	SOCKET IC 40-PIN	178133
IC12	IC DISPLAY DRIVER 4 DIGIT LED	133268
(IC12)	SOCKET IC 40-PIN	178133
J2	TERMINAL STRIP 14 PIN .025 SQ	117647
J7	TERMINAL STRIP 14 PIN .025 SQ	117647

Ref. No.	Description	Part No.
J9	TERMINAL STRIP 14 PIN .025 SQ	117647
J12	TERMINAL STRIP 14 PIN .025 SQ	117647
MOLD1	MOLD FUNCTION LED	017865
MOLD3	MOLD LED INDICATOR	017866
MOLD4	MOLD FUNCTION LED	017865
MOLD5	MOLD FUNCTION LED	017865
MOLD6	MOLD FUNCTION LED	017865
MOLD7	MOLD FUNCTION LED	017865
MOLD8	MOLD FUNCTION LED	017865
MOLD9	MOLD FUNCTION LED	017865
MOLD10	MOLD FUNCTION LED	017865
MOLD11	MOLD LED INDICATOR	017866
MOLD12	MOLD LED INDICATOR	017866
MOLD13	MOLD LED INDICATOR	017866
Q2	TRANSISTOR PNP	132224
R1	RES MF 47.5K 1% 1/4W	144108
R6	RES MF 3.3K 1% 1/4W	144095
R8	RES MF 10 OHM 1% 1/4W	144157
R10	RES NETWORK 5X47K BUSSED	144254
R12	RES NETWORK 9 X 47K BUS	144250
R13	RES NETWORK 9 X 47K BUS	144250
R14	RES NETWORK 9 X 47K BUS	144250
R15	RES MF 4.99K 1% 1/4W	144098
R18	RES MF 4.99K 1% 1/4W	144098
R25	RES FP 47 OHM 5% 1/4W	137042
S21	SWITCH ROT ENCODER 24 DETENT	146255
S22	SWITCH ROT ENCODER 24 DETENT	146255
S24	SWITCH ROT ENCODER 24 DETENT	146255
S25	SWITCH ROT ENCODER NO DETENT	146256

2C KEYBOARD PCB 050053

C13	CAP MONO .1UF 50V 20% Z5U	061305
C24	CAP ELECT 47UF 35V	066446
DS11	LED SQUARE RED	058109
(DS11)	SHRINK TUBING 3/8 LONG (077041)	077054
(DS11)	SPACER LED .220 LENGTH	163001
DS12	LED SQUARE RED	058109
(DS12)	SHRINK TUBING 3/8 LONG (077041)	077054
(DS12)	SPACER LED .220 LENGTH	163001
DS36	LED SQUARE RED	058109
(DS36)	SHRINK TUBING 3/8 LONG (077041)	077054
(DS36)	SPACER LED .220 LENGTH	163001
J2	CONN FFC 18PIN	117765
R16	RES MF 100 OHM 1% 1/4W	144196
R17	RES MF 332 OHM 1% 1/4W	144446
S17	SWITCH SLIDE	148059
S1	SWITCH TACT	150059
S2	SWITCH TACT	150059
S5	SWITCH TACT	150058
S7	SWITCH TACT	150058
S9	SWITCH TACT	150058
S10	SWITCH TACT	150058
S11	SWITCH TACT	150058
S12	SWITCH TACT	150058
S13	SWITCH TACT	150058
S14	SWITCH TACT	150058
S15	SWITCH TACT	150058
S16	SWITCH TACT	150058
SENSOR	SENSOR IR 38KHZ	121046

PARTS LIST Con't

3 SURROUND PCB 050168

Ref. No.	Description	Part No.	Ref. No.	Description	Part No.
BRKT1	BRACKET PCB CARD MOUNTING	003611	C68	CAP ELECT 10UF 16V	066580
(BRKT1)	SCREW MACH 6-32X1/4 PHL PN	100186	C69	CAP ELECT 10UF 16V	066580
(BRKT1)	NUT KEP 6-32 SPECIAL	102045	C70	CAP ELECT 10UF 16V	066580
C1	CAP ELECT 220UF 50V 20%	066254	C71	CAP ELECT 10UF 16V	066580
C2	CAP ELECT 100UF 25V	066573	C72	CAP ELECT 10UF 16V	066580
C3	CAP MONO .1UF 50V 20% Z5U	061346	C73	CAP ELECT 10UF 16V	066580
C4	CAP MONO .1UF 50V 20% Z5U	061346	C77	CAP ELECT 10UF 16V	066580
C5	CAP MONO .1UF 50V 20% Z5U	061346	C79	CAP ELECT 10UF 16V	066580
C6	CAP MONO .1UF 50V 20% Z5U	061346	C80	CAP ELECT 10UF 16V	066580
C7	CAP MONO .1UF 50V 20% Z5U	061346	C81	CAP ELECT 10UF 16V	066580
C8	CAP MONO .1UF 50V 20% Z5U	061346	C82	CAP ELECT 10UF 16V	066580
C9	CAP MONO .1UF 50V 20% Z5U	061346	C83	CAP ELECT 10UF 16V	066580
C10	CAP MONO .1UF 50V 20% Z5U	061346	C84	CAP ELECT 10UF 16V	066580
C11	CAP MONO .1UF 50V 20% Z5U	061346	C85	CAP ELECT 10UF 16V	066580
C12	CAP MONO .1UF 50V 20% Z5U	061346	C86	CAP ELECT 10UF 16V	066580
C13	CAP MONO .1UF 50V 20% Z5U	061346	C87	CAP ELECT 10UF 16V	066580
C14	CAP MONO .1UF 50V 20% Z5U	061346	C88	CAP ELECT 10UF 16V	066580
C15	CAP MONO .1UF 50V 20% Z5U	061346	C89	CAP ELECT 10UF 16V	066580
C16	CAP MONO 22PF 200V 10% NPO	061339	C94	CAP ELECT 10UF 16V	066580
C18	CAP MONO .1UF 50V 20% Z5U	061346	C95	CAP ELECT 10UF 16V	066580
C19	CAP MONO .1UF 50V 20% Z5U	061346	C96	CAP ELECT 10UF 16V	066580
C20	CAP MONO .1UF 50V 20% Z5U	061346	C97	CAP ELECT 10UF 16V	066580
C21	CAP MONO .1UF 50V 20% Z5U	061346	C98	CAP MONO 100PF 100V 10% NPO	061341
C22	CAP MONO .1UF 50V 20% Z5U	061346	C99	CAP MONO 100PF 100V 10% NPO	061341
C23	CAP MONO .1UF 50V 20% Z5U	061346	C100	CAP ELECT 10UF 16V	066580
C24	CAP MONO .1UF 50V 20% Z5U	061346	C101	CAP ELECT 10UF 16V	066580
C25	CAP MONO .1UF 50V 20% Z5U	061346	C102	CAP ELECT 10UF 16V	066580
C26	CAP MONO .1UF 50V 20% Z5U	061346	C103	CAP ELECT 10UF 16V	066580
C27	CAP MONO .1UF 50V 20% Z5U	061346	C104	CAP ELECT 10UF 16V	066580
C28	CAP MONO .1UF 50V 20% Z5U	061346	C105	CAP ELECT 10UF 16V	066580
C29	CAP MONO .1UF 50V 20% Z5U	061346	C106	CAP ELECT 10UF 16V	066580
C30	CAP MONO .1UF 50V 20% Z5U	061346	C107	CAP ELECT 10UF 16V	066580
C32	CAP MONO .1UF 50V 20% Z5U	061346	C110	CAP MONO .1UF 50V 20% Z5U	061346
C36	CAP MONO 22PF 200V 10% NPO	061339	C111	CAP MONO .1UF 50V 20% Z5U	061346
C37	CAP MONO 22PF 200V 10% NPO	061339	C113	CAP MONO .1UF 50V 20% Z5U	061346
C38	CAP MONO 22PF 200V 10% NPO	061339	C114	CAP MONO .1UF 50V 20% Z5U	061346
C39	CAP MONO 22PF 200V 10% NPO	061339	C115	CAP MONO .1UF 50V 20% Z5U	061346
C40	CAP MONO 22PF 200V 10% NPO	061339	C116	CAP MONO .1UF 50V 20% Z5U	061346
C41	CAP MONO 22PF 200V 10% NPO	061339	C119	CAP MONO .1UF 50V 20% Z5U	061346
C42	CAP MONO 22PF 200V 10% NPO	061339	C120	CAP MONO .1UF 50V 20% Z5U	061346
C43	CAP MONO 22PF 200V 10% NPO	061339	C121	CAP MPF 0.0022UF 5% 63VDC	064454
C44	CAP MONO 22PF 200V 10% NPO	061339	C128	CAP ELECT 1000UF 16V	066404
C45	CAP MONO 22PF 200V 10% NPO	061339	C129	CAP MONO .1UF 50V 20% Z5U	061346
C46	CAP MONO 22PF 200V 10% NPO	061339	C130	CAP MONO .1UF 50V 20% Z5U	061346
C47	CAP MONO 22PF 200V 10% NPO	061339	C131	CAP MONO .1UF 50V 20% Z5U	061346
C48	CAP MONO 22PF 200V 10% NPO	061339	C132	CAP MPF 0.0022UF 5% 63VDC	064454
C49	CAP MONO 22PF 200V 10% NPO	061339	C133	CAP MONO .1UF 50V 20% Z5U	061346
C50	CAP MONO 22PF 200V 10% NPO	061339	C134	CAP MONO .1UF 50V 20% Z5U	061346
C53	CAP ELECT 3300UF 35V	066509	C135	CAP MPF 0.0022UF 5% 63VDC	064454
C55	CAP ELECT 3300UF 35V	066509	C137	CAP MPF 0.1UF 5% 63VDC	064325
C56	CAP ELECT 3300UF 35V	066509	C138	CAP MPF 0.047UF 5% 63VDC	064320
C58	CAP ELECT 18000UF 16V	066460	C139	CAP MPF 0.047UF 5% 63VDC	064320
C59	CAP ELECT 10UF 50V	066445	C140	CAP MPF 0.1UF 5% 63VDC	064325
C60	CAP ELECT 10UF 50V	066445	C141	CAP MPF 0.047UF 5% 63VDC	064320
C61	CAP ELECT 10UF 16V	066580	C142	CAP MPF 0.047UF 5% 63VDC	064320
C62	CAP ELECT 10UF 16V	066580	C143	CAP MPF 0.047UF 5% 63VDC	064320
C65	CAP ELECT 10UF 16V	066580	C144	CAP MPF 0.047UF 5% 63VDC	064320
C66	CAP ELECT 10UF 16V	066580	C151	CAP MONO .1UF 50V 20% Z5U	061346
C67	CAP ELECT 10UF 16V	066580	C153	CAP MONO 22PF 200V 10% NPO	061339

PARTS LIST Con't

SURROUND PCB 050168 (Cont'd.)

Ref. No.	Description	Part No.	Ref. No.	Description	Part No.
C154	CAP MONO 100PF 100V 10% NPO	061341	C280	CAP MONO .1UF 50V 20% Z5U	061346
C155	CAP MONO 22PF 200V 10% NPO	061339	C281	CAP MONO .1UF 50V 20% Z5U	061346
C156	CAP MONO 22PF 200V 10% NPO	061339	C282	CAP MONO .1UF 50V 20% Z5U	061346
C157	CAP MONO 22PF 200V 10% NPO	061339	C284	CAP MONO .1UF 50V 20% Z5U	061346
C158	CAP MONO 22PF 200V 10% NPO	061339	C285	CAP MONO .1UF 50V 20% Z5U	061346
C159	CAP MONO 22PF 200V 10% NPO	061339	C286	CAP MONO .1UF 50V 20% Z5U	061346
C160	CAP MONO 22PF 200V 10% NPO	061339	C287	CAP MONO .1UF 50V 20% Z5U	061346
C161	CAP MONO 22PF 200V 10% NPO	061339	C288	CAP MONO .1UF 50V 20% Z5U	061346
C162	CAP MONO 100PF 100V 10% NPO	061341	C289	CAP MONO .1UF 50V 20% Z5U	061346
C167	CAP MONO 22PF 200V 10% NPO	061339	C290	CAP MONO .1UF 50V 20% Z5U	061346
C168	CAP MONO 100PF 100V 10% NPO	061341	C291	CAP ELECT 1000UF 16V	066404
C169	CAP MONO 22PF 200V 10% NPO	061339	C300	CAP MONO .1UF 50V 20% Z5U	061346
C170	CAP ELECT 100UF 25V	066573	C335	CAP ELECT 10UF 16V	066580
C171	CAP ELECT 100UF 25V	066573	C336	CAP ELECT 10UF 16V	066580
C172	CAP ELECT 100UF 25V	066573	C337	CAP ELECT 10UF 16V	066580
C174	CAP ELECT 100UF 25V	066573	C338	CAP ELECT 10UF 16V	066580
C175	CAP ELECT 1000UF 16V	066404	C340	CAP ELECT 47UF 50V	066215
C178	CAP MPF 0.1UF 100V	064338	C341	CAP MONO 1000PF 50V 10% NPO	061344
C180	CAP MONO 47PF 200V 10% NPO	061340	C342	CAP MONO 1000PF 50V 10% NPO	061344
C181	CAP MONO 47PF 200V 10% NPO	061340	C343	CAP MONO 1000PF 50V 10% NPO	061344
C182	CAP MONO 47PF 200V 10% NPO	061340	C344	CAP MONO 1000PF 50V 10% NPO	061344
C183	CAP MONO 47PF 200V 10% NPO	061340	C350	CAP ELECT 22UF 100V	066574
C184	CAP MONO 47PF 200V 10% NPO	061340	C351	CAP ELECT 47UF 50V	066215
C185	CAP MONO 47PF 200V 10% NPO	061340	C393	CAP MONO .1UF 50V 20% Z5U	061346
C186	CAP MPF 0.1UF 100V	064338	C394	CAP MONO .1UF 50V 20% Z5U	061346
C188	CAP MPF 1UF 5% 63VDC	064337	C395	CAP MONO 220PF 200V 10% NPO	061342
C189	CAP MPF 1UF 5% 63VDC	064337	C396	CAP MONO .1UF 50V 20% Z5U	061346
C192	CAP MPF 1UF 5% 63VDC	064337	C397	CAP MONO 220PF 200V 10% NPO	061342
C193	CAP MPF 1UF 5% 63VDC	064337	C398	CAP MONO .1UF 50V 20% Z5U	061346
C194	CAP ELECT 470UF 50V	066469	C399	CAP MONO .1UF 50V 20% Z5U	061346
C195	CAP ELECT 470UF 50V	066469	C390	CAP ELECT 470UF 50V	066469
C196	CAP MONO 22PF 200V 10% NPO	061339	C450	CAP ELECT 10UF 16V	066580
C197	CAP MONO 22PF 200V 10% NPO	061339	D1	DIODE ZENER 33V 5% 1/2W	070182
C198	CAP MONO 22PF 200V 10% NPO	061339	D2	DIODE ZENER 5.1V	070186
C199	CAP MONO 22PF 200V 10% NPO	061339	D3	DIODE ZENER 6.2V 5% 500MW	070184
C200	CAP ELECT 10UF 16V	066580	D5	DIODE SILICON	070174
C201	CAP MONO 22PF 200V 10% NPO	061339	D6	DIODE SILICON	070174
C202	CAP MONO 47PF 200V 10% NPO	061340	D7	DIODE SILICON	070174
C203	CAP ELECT 10UF 16V	066580	D8	DIODE SILICON	070174
C204	CAP MONO 22PF 200V 10% NPO	061339	D9	DIODE SILICON	070174
C205	CAP MONO 22PF 200V 10% NPO	061339	D10	DIODE SILICON	070174
C206	CAP MONO 1000PF 50V 10% NPO	061344	D11	DIODE SILICON	070174
C215	CAP ELECT 10UF 16V	066580	D19	DIODE SILICON	070174
C220	CAP ELECT 10UF 16V	066580	D27	DIODE RECTIFIER	070175
C221	CAP ELECT 10UF 16V	066580	D28	DIODE RECTIFIER	070175
C236	CAP MONO .1UF 50V 20% Z5U	061346	D29	DIODE RECT SI 3A 100V	070176
C256	CAP ELECT 10UF 16V	066580	D30	DIODE RECT SI 3A 100V	070176
C250	CAP MONO 22PF 200V 10% NPO	061339	D31	DIODE RECT SI 3A 100V	070176
C251	CAP MONO 47PF 200V 10% NPO	061340	D32	DIODE RECT SI 3A 100V	070176
C254	CAP MONO .1UF 50V 20% Z5U	061346	D34	DIODE RECTIFIER	070175
C255	CAP MONO .1UF 50V 20% Z5U	061346	D35	DIODE RECTIFIER	070175
C257	CAP ELECT 10UF 16V	066580	D36	DIODE RECTIFIER	070175
C258	CAP MONO 22PF 200V 10% NPO	061339	D37	DIODE RECTIFIER	070175
C259	CAP MONO 22PF 200V 10% NPO	061339	D40	DIODE RECTIFIER	070175
C260	CAP MONO 22PF 200V 10% NPO	061339	D41	DIODE RECTIFIER	070175
C261	CAP MONO 22PF 200V 10% NPO	061339	D100	DIODE RECTIFIER	070175
C262	CAP ELECT 10UF 16V	066580	D101	DIODE RECTIFIER	070175
C263	CAP ELECT 10UF 16V	066580	F1	FUSE 3.15A SLO-BLO 5X20 IEC	089098
C264	CAP ELECT 10UF 16V	066580	(F1)	HOLDER FUSE 5X20MM PCB MOUNT	178159
C265	CAP ELECT 10UF 16V	066580	F2	FUSE 3.15A SLO-BLO 5X20 IEC	089098

PARTS LIST Con't

SURROUND PCB 050168 (Cont'd.)

Ref. No.	Description	Part No.	Ref. No.	Description	Part No.
(F2)	HOLDER FUSE 5X20MM PCB MOUNT	178159	(IC33)	WASHER SHLDR #10 BLK NYLN INS	104101
F3	FUSE 0,5A SLO-BLO 5X20	089092	IC34	IC VOLTAGE REGULATOR -15V	133087
(F3)	HOLDER FUSE 5X20MM PCB MOUNT	178159	(IC34)	INSULATOR ISOSTRATE TO 220	084133
	SCREW MACH 4-40 X 3/8 PHIL PAN	100178	(IC34)	HEATSINK TO-220	080017
	NUT KEP 4-40 CADMIUM PLATE	102001	(IC34)	SCREW MACH 4-40 X 3/8 PHIL PAN	100178
	WASHER SHLDR #10 BLK NYLN INS	104101	(IC34)	NUT KEP 4-40 CADMIUM PLATE	102001
IC1	IC VOLUME CONTROL	133187	(IC34)	WASHER SHLDR #10 BLK NYLN INS	104101
(IC1)	SOCKET 20-PIN IC	178124	IC35	IC MONOSTB MULTIVIB X 2	133182
IC3	IC QUAD OPERATIONAL AMPLIFIER	133238	IC36	IC REGULATOR +5V	133108
IC4	IC REGULATOR 3.3V LOW DROPOUT	133393	(IC36)	INSULATOR ISOSTRATE TO 220	084133
(IC4)	INSULATOR ISOSTRATE TO 220	084133	(IC36)	HEATSINK TO-220	080017
(IC4)	HEATSINK TO-220	080017	(IC36)	SCREW MACH 4-40 X 3/8 PHIL PAN	100178
(IC4)	SCREW MACH 4-40 X 3/8 PHIL PAN	100178	(IC36)	NUT KEP 4-40 CADMIUM PLATE	102001
(IC4)	NUT KEP 4-40 CADMIUM PLATE	102001	(IC36)	WASHER SHLDR #10 BLK NYLN INS	104101
(IC4)	WASHER SHLDR #10 BLK NYLN INS	104101	IC37	IC REGULATOR 5V 1.5A LOW DROP	133365
IC5	IC VOLUME CONTROL	133187	(IC37)	INSULATOR ISOSTRATE TO 220	084133
(IC5)	SOCKET 20-PIN IC	178124	(IC37)	HEATSINK TO-220	080017
IC6	IC VOLUME CONTROL	133187	(IC37)	SCREW MACH 4-40 X 3/8 PHIL PAN	100178
(IC6)	SOCKET 20-PIN IC	178124	(IC37)	NUT KEP 4-40 CADMIUM PLATE	102001
IC7	IC VOLUME CONTROL	133187	(IC37)	WASHER SHLDR #10 BLK NYLN INS	104101
(IC7)	SOCKET 20-PIN IC	178124	IC38	COUPLER OPTICAL SCHMITT OUTPUT	131023
IC8	IC VOLUME CONTROL	133187	IC40	IC BIFET OP AMP	133310
(IC8)	SOCKET 20-PIN IC	178124	IC41	IC BIFET OP AMP	133310
IC9	IC VOLUME CONTROL	133187	IC42	IC BIFET OP AMP	133310
(IC9)	SOCKET 20-PIN IC	178124	IC44	IC BIFET OP AMP	133310
IC10	IC VOLUME CONTROL	133187	IC45	IC BIFET OP AMP	133310
(IC10)	SOCKET 20-PIN IC	178124	IC46	IC BIFET OP AMP	133310
IC11	IC VOLUME CONTROL	133187	IC48	IC 2 INPUT X 4	133167
(IC11)	SOCKET 20-PIN IC	178124	IC49	IC 2 INPUT X 4	133167
IC16	IC VOLUME CONTROL	133187	IC51	IC 2 INPUT X 4	133167
(IC16)	SOCKET 20-PIN IC	178124	IC52	IC 2 INPUT X 4	133167
IC17	IC VOLUME CONTROL	133187	IC55	IC QUAD OPERATIONAL AMPLIFIER	133238
(IC17)	SOCKET 20-PIN IC	178124	C56	IC QUAD OPERATIONAL AMPLIFIER	133238
IC18	IC OCTAL D-TYPE FLIP-FLOP	133348	IC59	COUPLER OPTICAL SCHMITT OUTPUT	131023
IC19	IC OCTAL D-TYPE FLIP-FLOP	133348	IC66	IC SPST QUAD FET SWITCHES N O	133426
IC20	IC VOLUME CONTROL	133187	IC69	IC OPERATIONAL AMPLIFIER	133189
(IC20)	SOCKET 20-PIN IC	178124	IC70	IC OCTAL DAR TRNS ARRAY W/DIODE	133360
IC21	IC VOLUME CONTROL	133187	IC71	IC SPST QUAD FET SWITCHES N O	133426
(IC21)	SOCKET 20-PIN IC	178124	IC73	IC QUAD OPERATIONAL AMPLIFIER	133238
IC22	IC VOLUME CONTROL	133187	IC80	IC REGULATOR 5V 1.5A LOW DROP	133365
(IC22)	SOCKET 20-PIN IC	178124	(IC80)	INSULATOR ISOSTRATE TO 220	084133
IC23	IC VOLUME CONTROL	133187	(IC80)	HEATSINK TO-220	080017
(IC23)	SOCKET 20-PIN IC	178124	IC91	IC VOLUME CONTROL	133187
IC24	IC VOLUME CONTROL	133187	IC92	IC VOLUME CONTROL	133187
(IC24)	SOCKET 20-PIN IC	178124	(IC92)	SOCKET 20-PIN IC	178124
IC25	IC QUAD OPERATIONAL AMPLIFIER	133238	IC93	IC BIFET OP AMP	133310
IC26	IC QUAD OPERATIONAL AMPLIFIER	133238	IC94	IC BIFET OP AMP	133310
IC27	IC QUAD OPERATIONAL AMPLIFIER	133238	IC150	IC HEX INVERTER	133193
IC28	IC QUAD OPERATIONAL AMPLIFIER	133238	J1	CONN MALE 10 POS	117219
IC30	IC RS232 LINE DRIVER	133380	J2	CONN FFC 12 PIN	117720
(IC30)	SOCKET IC DIP-16 PIN DUAL	178091	J3	CONN FFC 12 PIN	117720
IC31	IC REGULATOR +12 VOLT	133119	J6	CONN MALE 9 POS FRICTION LOCK	117244
(IC31)	INSULATOR ISOSTRATE TO 220	084133	J7	CONN MALE 5 PIN 0.1 POST ASSY	117216
(IC31)	HEATSINK TO-220	080016	J8	CONN MALE 10 POS	117219
IC32	IC NEG 24V REGULATOR	133306	J9	CONN SUB D 25 PIN	117818
IC33	IC REGULATOR +15 VOLT	133086	J10	CONN MALE 10 POS	117219
(IC33)	INSULATOR ISOSTRATE TO 220	084133	J14	CONN 3 POS MALE MTS100 NORMAL	117214
(IC33)	HEATSINK TO-220	080017	J15	CONN MALE 9 POS FRICTION LOCK	117244
(IC33)	SCREW MACH 4-40 X 3/8 PHIL PAN	100178	J16	CONN MALE 10 POS	117219
(IC33)	NUT KEP 4-40 CADMIUM PLATE	102001	J19	CONN MALE 10 POS	117219

PARTS LIST Con't

SURROUND PCB 050168 (Cont'd.)

Ref. No.	Description	Part No.	Ref. No.	Description	Part No.
J20	CONN SUB-D 9-PIN	117507	R11	RES NETWORK 2X100 OHM ISOLATED	144680
J20	CONN 4 PIN	117215	R12	RES 1.37K 1% 1/4W	144515
J21	JACK HEADPHONE DUAL BLACK 1/8	117549	R14	RES 1.37K 1% 1/4W	144515
J22	BLADE FASTON W/FEET	117708	R15	RES 1.37K 1% 1/4W	144515
J23	BLADE FASTON W/FEET	117708	R16	RES 1.37K 1% 1/4W	144515
J24	BLADE FASTON W/FEET	117708	R17	RES MF 1.65K 1% 1/4W	144516
J26	BLADE FASTON W/FEET	117708	R22	RES NETWORK 470KX6	144690
J27	BLADE FASTON W/FEET	117708	R23	RES NETWORK 4X1K ISO	144500
J28	BLADE FASTON W/FEET	117708	R25	RES NETWORK 4X1K ISO	144500
J29	BLADE FASTON W/FEET	117708	R27	RES MF 1.1K 1% 1/4W	144514
J30	BLADE FASTON W/FEET	117708	R28	RES POLYSWITCH RXE030	144670
J31	CONN 4 PIN	117215	R29	RES POLYSWITCH RXE030	144670
J32	CONN FFC 12 PIN	117720	R30	RES MF 10K 1% 1/4W	144504
J33	JACK HEADPHONE DUAL BLACK 1/8	117549	R31	RES MF 1.21K 1% 1/4W	144566
J34	JACK HEADPHONE DUAL BLACK 1/8	117549	R39	RES MF 100K 1% 1/4W	144528
J41	CONN 4 PIN	117215	R40	RES MF 8.25K 1% 1/4W	144549
J40	JACK RCA 4X2 WHT/RED 14MM	117791	R42	RES MF 10K 1% 1/4W	144504
J41	JACK RCA 4X2 WHT/RED 14MM	117791	R43	RES NET 2 X 22K ISOLATED	144689
J93	JACK RCA 1X2 WHT/RED 14MM	117788	R44	RES NET 2 X 22K ISOLATED	144689
J45	JACK RJ45	117780	R45	RES MF 20K 1% 1/4W	144524
J46	JACK RJ45	117780	R47	RES MF 20K 1% 1/4W	144524
K4	RELAY REED FORM 1A 5V 500 OHMS	087050	R48	RES MF 3.24K 1% 1/4W	144540
K5	RELAY REED FORM 1A 5V 500 OHMS	087050	R50	RES MF 20K 1% 1/4W	144524
K6	RELAY REED FORM 1A 5V 500 OHMS	087050	R51	RES MF 3.24K 1% 1/4W	144540
K7	RELAY REED FORM 1A 5V 500 OHMS	087050	R54	RES MF 100K 1% 1/4W	144528
K8	RELAY REED FORM 1A 5V 500 OHMS	087050	R55	RES NET 2 X 22K ISOLATED	144689
K9	RELAY REED FORM 1A 5V 500 OHMS	087050	R57	RES MF 10K 1% 1/4W	144504
K10	RELAY REED FORM 1A 5V 500 OHMS	087050	R58	RES MF 1.65K 1% 1/4W	144516
K11	RELAY REED FORM 1A 5V 500 OHMS	087050	R59	RES MF 1.65K 1% 1/4W	144516
K12	RELAY POWER TV5 24V	087069	R60	RES MF 1.65K 1% 1/4W	144516
K13	RELAY 24VDC 5A 277VAC	087057	R63	RES NETWORK 2X100 OHM ISOLATED	144680
K15	RELAY REED FORM 1A 5V 500 OHMS	087050	R64	RES MF 10K 1% 1/4W	144504
K20	RELAY REED FORM 1A 5V 500 OHMS	087050	R66	RES MF 100K 1% 1/4W	144528
K21	RELAY REED FORM 1A 5V 500 OHMS	087050	R67	RES MF 3.24K 1% 1/4W	144540
L10	BEADS FERRITE LEADED	076023	R68	RES MF 20K 1% 1/4W	144524
L11	BEADS FERRITE LEADED	076023	R69	RES MF 3.24K 1% 1/4W	144540
L12	BEADS FERRITE LEADED	076023	R70	RES MF 20K 1% 1/4W	144524
L17	BEADS FERRITE LEADED	076023	R72	RES NETWORK 2X220K ISO	144678
PCB1	PC BD SURROUND	129635	R74	RES NET 2 X 22K ISOLATED	144689
P1	SOCKET STRIP .025 SQ 20 PIN	117642	R78	RES NETWORK 2X100 OHM ISOLATED	144680
P2	CONN HEADER SOCKET 2X20	117799	R79	RES NETWORK 2X100 OHM ISOLATED	144680
P3	SOCKET STRIP .025 SQ 20 PIN	117642	R82	RES MF 1.65K 1% 1/4W	144516
P6	SOCKET STRIP .025 SQ 20 PIN	117642	R87	RES MF 10K 1% 1/4W	144504
Q3	TRANSISTOR NPN 2K/REEL	132317	R88	RES MF 8.25K 1% 1/4W	144549
Q4	IC VOLTAGE REGULATOR -5.2V	133088	R89	RES MF 20K 1% 1/4W	144524
(Q4)	HEATSINK TO-220	080017	R90	RES MF 8.25K 1% 1/4W	144549
(Q4)	INSULATOR ISOSTRATE TO 220	084133	R91	RES MF 20K 1% 1/4W	144524
Q9	TRANSISTOR NPN 2K/REEL	132317	R115	RES MF 100K 1% 1/4W	144528
Q10	TRANSISTOR NPN DAR	132303	R116	RES MF 3.24K 1% 1/4W	144540
Q11	TRANSISTOR NPN 2K/REEL	132317	R117	RES MF 20K 1% 1/4W	144524
R1	RES MF 1.1K 1% 1/4W	144514	R118	RES MF 3.24K 1% 1/4W	144540
R2	RES MF 20K 1% 1/4W	144524	R119	RES MF 100K 1% 1/4W	144528
R6	RES MF 20K 1% 1/4W	144524	R120	RES MF 10K 1% 1/4W	144504
R3	RES WW 100 OHM 10% 2W BWH	139134	R121	RES MF 10K 1% 1/4W	144504
R4	RES MF 8.25K 1% 1/4W	144549	R122	RES MF 8.25K 1% 1/4W	144549
R5	RES FP 1.1 OHM 1/4W 5%	137002	R123	RES MF 20K 1% 1/4W	144524
R7	RES MF 10K 1% 1/4W	144504	R124	RES MF 8.25K 1% 1/4W	144549
R8	RES NETWORK 2X100 OHM ISOLATED	144680	R125	RES MF 20K 1% 1/4W	144524
R9	RES MF 100 OHM 1% 1/4W	144568	R126	RES MF 20K 1% 1/4W	144524
R10	RES MF 75 OHM 1% 1/4W	144644	R127	RES MF 3.24K 1% 1/4W	144540

PARTS LIST Con't

SURROUND PCB 050168 (Cont'd.)

Ref. No.	Description	Part No.	Ref. No.	Description	Part No.
R128	RES MF 20K 1% 1/4W	144524	R227	RES 1.37K 1% 1/4W	144515
R129	RES MF 3.24K 1% 1/4W	144540	R228	RES 1.37K 1% 1/4W	144515
R131	RES MF 10K 1% 1/4W	144504	R229	RES 1.37K 1% 1/4W	144515
R133	RES NET 2 X 22K ISOLATED	144689	R230	RES 1.37K 1% 1/4W	144515
R135	RES NET 2 X 22K ISOLATED	144689	R231	RES 1.37K 1% 1/4W	144515
R137	RES NET 2 X 22K ISOLATED	144689	R232	RES MF 100K 1% 1/4W	144528
R138	RES NET 2 X 22K ISOLATED	144689	R233	RES MF 100K 1% 1/4W	144528
R141	RES NET 2 X 22K ISOLATED	144689	R234	RES MF 100K 1% 1/4W	144528
R146	RES MF 100K 1% 1/4W	144528	R235	RES 1.37K 1% 1/4W	144515
R152	RES NET 2 X 22K ISOLATED	144689	R236	RES 1.37K 1% 1/4W	144515
R158	RES MF 30.1K 1% 1/4W	144573	R237	RES 1.37K 1% 1/4W	144515
R159	RES MF 30.1K 1% 1/4W	144573	R238	RES 1.37K 1% 1/4W	144515
R161	RES MF 30.1K 1% 1/4W	144573	R239	RES NETWORK 2X100 OHM ISOLATED	144680
R165	RES MF 61.9K OHM 1/4W	144596	R240	RES NETWORK 2X100 OHM ISOLATED	144680
R167	RES MF 40.2K 1% 1/4W	144525	R241	RES NETWORK 2X100 OHM ISOLATED	144680
R168	RES MF 40.2K 1% 1/4W	144525	R243	RES NETWORK 2X100 OHM ISOLATED	144680
R170	RES MF 61.9K OHM 1/4W	144596	R244	RES NETWORK 2X100 OHM ISOLATED	144680
R171	RES MF 4.02K 1% 1/4W	144519	R245	RES NETWORK 2X100 OHM ISOLATED	144680
R172	RES MF 1.65K 1% 1/4W	144516	R278	RES MF 10 OHM 1% 1/4W	144553
R173	RES MF 2.67K 1% 1/4W	144534	R279	RES MF 10 OHM 1% 1/4W	144553
R174	RES MF 1.65K 1% 1/4W	144516	R280	RES MF 10 OHM 1% 1/4W	144553
R175	RES MF 221 OHM 1% 1/4W	144559	R281	RES MF 10 OHM 1% 1/4W	144553
R176	RES MF 1.1K 1% 1/4W	144514	R282	RES MF 10 OHM 1% 1/4W	144553
R177	RES MF 27.4K 1% 1/4W	144545	R283	RES MF 10 OHM 1% 1/4W	144553
R178	RES MF 20K 1% 1/4W	144524	R299	RES MF 10K 1% 1/4W	144504
R179	RES MF 35.7K 1% 1/4W	144368	R300	RES MF 10K 1% 1/4W	144504
R183	RES MF 35.7K 1% 1/4W	144368	R313	RES MF 100K 1% 1/4W	144528
R184	RES MF 20K 1% 1/4W	144524	R314	RES MF 100K 1% 1/4W	144528
R185	RES MF 27.4K 1% 1/4W	144545	R315	RES MF 10 OHM 1% 1/4W	144553
R189	RES MF 221 OHM 1% 1/4W	144559	R316	RES MF 100K 1% 1/4W	144528
R190	RES MF 100K 1% 1/4W	144528	R317	RES MF 10 OHM 1% 1/4W	144553
R191	RES MF 100K 1% 1/4W	144528	R318	RES MF 100K 1% 1/4W	144528
R192	RES MF 100K 1% 1/4W	144528	R322	RES MF 1.65K 1% 1/4W	144516
R193	RES NET 2 X 22K ISOLATED	144689	R325	RES MF 1.65K 1% 1/4W	144516
R196	RES NET 2 X 22K ISOLATED	144689	R326	RES MF 1.65K 1% 1/4W	144516
R201	RES MF 10 OHM 1% 1/4W	144553	R340	RES FP 10 OHM 5% 1/4W	137105
R203	RES MF 100K 1% 1/4W	144528	R393	RES MF 1.1K 1% 1/4W	144514
R204	RES MF 100K 1% 1/4W	144528	R321	RES MF 1.65K 1% 1/4W	144516
R205	RES MF 100K 1% 1/4W	144528	R319	RES 1.37K 1% 1/4W	144515
R206	RES MF 100K 1% 1/4W	144528	R320	RES 1.37K 1% 1/4W	144515
R207	RES MF 100K 1% 1/4W	144528	R323	RES 1.37K 1% 1/4W	144515
R208	RES MF 100K 1% 1/4W	144528	R324	RES 1.37K 1% 1/4W	144515
R209	RES MF 100K 1% 1/4W	144528	R327	RES NET 2 X 22K ISOLATED	144689
R210	RES MF 100K 1% 1/4W	144528	R328	RES NET 2 X 22K ISOLATED	144689
R211	RES MF 100K 1% 1/4W	144528	R329	RES NETWORK 2X220K ISO	144678
R212	RES MF 100K 1% 1/4W	144528	R330	RES NETWORK 2X100 OHM ISOLATED	144680
R213	RES MF 1.65K 1% 1/4W	144516	R350	RES MF 10 OHM 1% 1/4W	144553
R214	RES MF 5.62K OHM 1% 1/4W	144647	R360	RES MF 4.75K 1% 1/4W	144520
R215	RES MF 1.65K 1% 1/4W	144516	R361	RES MF 4.75K 1% 1/4W	144520
R216	RES MF 1.65K 1% 1/4W	144516	R375	RES MF 3.24K 1% 1/4W	144540
R217	RES MF 1.65K 1% 1/4W	144516	R376	RES MF 1.65K 1% 1/4W	144516
R218	RES MF 1.65K 1% 1/4W	144516	R380	RES NETWORK 2X100 OHM ISOLATED	144680
R219	RES MF 1.65K 1% 1/4W	144516	R382	RES NETWORK 2X100 OHM ISOLATED	144680
R220	RES MF 1.65K 1% 1/4W	144516	R384	RES NETWORK 2X100 OHM ISOLATED	144680
R221	RES MF 1.65K 1% 1/4W	144516	R386	RES MF 61.9K OHM 1/4W	144596
R222	RES MF 1.65K 1% 1/4W	144516	R387	RES MF 61.9K OHM 1/4W	144596
R223	RES MF 5.62K OHM 1% 1/4W	144647	R390	RES NETWORK 2X220K ISO	144678
R224	RES 1.37K 1% 1/4W	144515	R391	RES NETWORK 2X220K ISO	144678
R225	RES 1.37K 1% 1/4W	144515	R392	RES NETWORK 2X220K ISO	144678
R226	RES 1.37K 1% 1/4W	144515	R400	RES MF 100K 1% 1/4W	144528

PARTS LIST Con't

SURROUND PCB 050168 (Cont'd.)

Ref. No.	Description	Part No.	Ref. No.	Description	Part No.
R401	RES MF 100K 1% 1/4W	144528	IC24	IC 2 INPUT X 4	133167
R402	RES MF 100K 1% 1/4W	144528	IC25	IC HEX UNBUF INVERTER	133173
R403	RES MF 100K 1% 1/4W	144528	IC35	IC 8 LN DRIVER ARRAY	133180
R450	RES MF 100K 1% 1/4W	144528	(IC35)	SOCKET IC 18-PIN DIP	178109
S1	SWITCH SLIDE	148059	IC40	IC 8-INPUT SEL/MULTI	133219
	STANDOFF 4-40 X 7/16 (M/F)	112084	J1	CONN MALE 7 PIN	117217
	DECAL FUSE 3.15A SLO-BLO	126976	J2	CONN 4 PIN	117215
			J3	CONN MALE 6 POS FRICTION LOCK	117218
			J5	CONN MALE 9 POS FRICTION LOCK	117244
			J8	JACK MINI	117494
			J9	JACK MINI	117494
			J14	JACK MINI	117494
			J15	JACK MINI	117494
			J16	JACK MINI	117494
			J17	JACK MINI	117494
			J18	JACK MINI	117494
			J19	JACK MINI	117494
			J20	JACK MINI	117494
			J21	JACK MINI	117494
			J22	JACK MINI	117494
			J25	CONN 11 POS MALE	117279
			J30	CONN 4 PIN	117215
			J32	CONN MALE 7 PIN	117217
			J37	CONN MALE 10 POS RIGHT ANGLE	117260
			J36	JACK RCA 4X1 ORANGE 14MM	117778
			L1	INDUCTOR 3.9UH 5%	122255
			L2	CHOKE 18UH 5%-10%	122224
			L3	CHOKE 18UH 5%-10%	122224
			L4	CHOKE 18UH 5%-10%	122224
			L5	CHOKE 18UH 5%-10%	122224
			L6	CHOKE 18UH 5%-10%	122224
			L7	CHOKE 18UH 5%-10%	122224
			L8	CHOKE 18UH 5%-10%	122224
			L9	CHOKE 18UH 5%-10%	122224
			L10	CHOKE 18UH 5%-10%	122224
			OPT1	FIBER OPTIC RECEIVER	058156
			OPT2	FIBER OPTIC RECEIVER	058156
			OPT3	FIBER OPTIC RECEIVER	058156
			OPT4	TRANSMITTER FIBER OPTIC	058157
			R1	RES NETWORK 5 X 100 ISO	144677
			R2	RES NETWORK 5 X 100 ISO	144677
			R3	RES NETWORK 5 X 100 ISO	144677
			R5	RES MF 100K 1% 1/4W	144528
			R6	RES MF 100K 1% 1/4W	144528
			R7	RES MF 100K 1% 1/4W	144528
			R8	RES MF 100K 1% 1/4W	144528
			R10	RES MF 100K 1% 1/4W	144528
			R11	RES MF 100K 1% 1/4W	144528
			R20	RES MF 1K 1% 1/4W	144513
			R30	RES MF 75 OHM 1% 1/4W	144644
			R31	RES MF 75 OHM 1% 1/4W	144644
			R32	RES MF 75 OHM 1% 1/4W	144644
			R33	RES MF 365 OHM 1% 1/4W	144505
			R34	RES MF 95.3 OHM 1% 1/4W	144572
			R40	RES MF 10K 1% 1/4W	144504
			R60	RES MF 100K 1% 1/4W	144528
			R61	RES MF 1K 1% 1/4W	144513
			R63	RES MF 100K 1% 1/4W	144528
			T1	TRANSFORMER DIGITAL INTERFACE	159285
			U1	IC REGULATOR 12V	133156

4 DATA PCB 050164

Ref. No.	Description	Part No.
	PCB CARD MOUNTING	003611
C1	CAP MONO .1UF 50V 20% Z5U	061346
C2	CAP MONO .1UF 50V 20% Z5U	061346
C3	CAP MONO .1UF 50V 20% Z5U	061346
C4	CAP MONO .1UF 50V 20% Z5U	061346
C5	CAP MONO .1UF 50V 20% Z5U	061346
C6	CAP MONO .1UF 50V 20% Z5U	061346
C7	CAP MONO .1UF 50V 20% Z5U	061346
C8	CAP MONO .1UF 50V 20% Z5U	061346
C10	CAP MPF 0.1UF 5% 63VDC	064325
C11	CAP MPF 0.1UF 5% 63VDC	064325
C12	CAP MPF 0.1UF 5% 63VDC	064325
C13	CAP MPF 0.1UF 5% 63VDC	064325
C14	CAP MONO .1UF 50V 20% Z5U	061346
C15	CAP ELECT 47UF 50V	066215
C16	CAP MONO .1UF 50V 20% Z5U	061346
C17	CAP MONO .1UF 50V 20% Z5U	061346
C18	CAP MONO .1UF 50V 20% Z5U	061346
C19	CAP MONO .1UF 50V 20% Z5U	061346
C21	CAP MONO .1UF 50V 20% Z5U	061346
C22	CAP ELECT 47UF 50V	066215
C23	CAP MONO .1UF 50V 20% Z5U	061346
C24	CAP ELECT 47UF 50V	066215
C25	CAP MONO .1UF 50V 20% Z5U	061346
C26	CAP ELECT 47UF 50V	066215
C27	CAP ELECT 47UF 50V	066215
C30	CAP MONO 220PF 200V 10% NPO	061342
C35	CAP MONO .1UF 50V 20% Z5U	061346
C36	CAP MONO .1UF 50V 20% Z5U	061346
C40	CAP MONO 220PF 200V 10% NPO	061342
C41	CAP MONO 220PF 200V 10% NPO	061342
D20	DIODE SILICON	070174
D21	DIODE SILICON	070174
	SCREW MACH 6-32X1/4 PHL PN	100186
	NUT KEP 6-32 SPECIAL	102045
IC1	IC 2 INPUT X 4	133167
IC2	IC 2 INPUT X 4	133167
IC3	IC NOR 2 INPUT X 4	133176
IC4	IC AND 2 INPUT X 4	133175
IC5	IC SHFT REG SER-PAR	133186
IC6	IC SHFT REG SER-PAR	133186
IC7	IC SHFT REG SER-PAR	133186
IC8	IC SHFT REG SER-PAR	133186
IC9	IC SHFT REG SER-PAR	133186
IC10	IC 8 LN DRIVER ARRAY	133180
(IC10)	SOCKET IC 18-PIN DIP	178109
IC11	IC 8 LN DRIVER ARRAY	133180
(IC11)	SOCKET IC 18-PIN DIP	178109
IC12	IC 8 LN DRIVER ARRAY	133180
(IC12)	SOCKET IC 18-PIN DIP	178109
IC23	IC LINE RECEIVER QUAD	133428

PARTS LIST Con't

5 S-VIDEO PCB 050166

Ref. No.	Description	Part No.	Ref. No.	Description	Part No.
C3	CAP MONO .1UF 50V 20% Z5U	061346	R4	RES MF 75 OHM 1% 1/4W	144644
C4	CAP MONO .1UF 50V 20% Z5U	061346	R5	RES MF 75 OHM 1% 1/4W	144644
C7	CAP MONO .1UF 50V 20% Z5U	061346	R6	RES MF 806 OHM 1% 1/4W	144512
C8	CAP MONO .1UF 50V 20% Z5U	061346	R7	RES MF 75 OHM 1% 1/4W	144644
C9	CAP MONO .1UF 50V 20% Z5U	061346	R8	RES MF 75 OHM 1% 1/4W	144644
C11	CAP MONO .1UF 50V 20% Z5U	061346	R9	RES MF 75 OHM 1% 1/4W	144644
C13	CAP MONO .1UF 50V 20% Z5U	061346	R10	RES MF 75 OHM 1% 1/4W	144644
C15	CAP MONO .1UF 50V 20% Z5U	061346	R11	RES MF 806 OHM 1% 1/4W	144512
C16	CAP ELECT 10UF 50V	066445	R12	RES MF 75 OHM 1% 1/4W	144644
C17	CAP ELECT 10UF 50V	066445	R13	RES MF 75 OHM 1% 1/4W	144644
C24	CAP MONO .1UF 50V 20% Z5U	061346	R14	RES MF 75 OHM 1% 1/4W	144644
C26	CAP MONO .1UF 50V 20% Z5U	061346	R16	RES MF 75 OHM 1% 1/4W	144644
C30	CAP MONO .1UF 50V 20% Z5U	061346	R21	RES MF 10K 1% 1/4W	144504
C32	CAP MONO .1UF 50V 20% Z5U	061346	R22	RES MF 806 OHM 1% 1/4W	144512
C34	CAP MONO .1UF 50V 20% Z5U	061346	R23	RES MF 806 OHM 1% 1/4W	144512
C36	CAP MONO .1UF 50V 20% Z5U	061346	R24	RES MF 10K 1% 1/4W	144504
C48	CAP ELECT 10UF 50V	066445	R25	RES MF 75 OHM 1% 1/4W	144644
C49	CAP ELECT 10UF 50V	066445	R33	RES MF 75 OHM 1% 1/4W	144644
C51	CAP ELECT 10UF 50V	066445	R34	RES MF 10K 1% 1/4W	144504
C54	CAP ELECT 10UF 50V	066445	R35	RES MF 75 OHM 1% 1/4W	144644
C59	CAP MONO .1UF 50V 20% Z5U	061346	R36	RES MF 806 OHM 1% 1/4W	144512
C60	CAP MONO .1UF 50V 20% Z5U	061346	R37	RES MF 806 OHM 1% 1/4W	144512
C61	CAP MONO .1UF 50V 20% Z5U	061346	R38	RES MF 806 OHM 1% 1/4W	144512
C70	CAP MONO .1UF 50V 20% Z5U	061346	R39	RES MF 10K 1% 1/4W	144504
C71	CAP MONO .1UF 50V 20% Z5U	061346	R40	RES MF 806 OHM 1% 1/4W	144512
C72	CAP MONO .1UF 50V 20% Z5U	061346	R50	RES FP 10 OHM 5% 1/4W	137105
C73	CAP MONO .1UF 50V 20% Z5U	061346	R52	RES FP 10 OHM 5% 1/4W	137105
C74	CAP ELECT 47UF 25V 20% NP	066378	R54	RES FP 10 OHM 5% 1/4W	137105
C75	CAP ELECT 47UF 25V 20% NP	066378	R56	RES FP 10 OHM 5% 1/4W	137105
C76	CAP ELECT 47UF 25V 20% NP	066378	R60	RES NETWORK 8X47KI	144691
C77	CAP ELECT 47UF 25V 20% NP	066378	R61	RES NETWORK 8X47KI	144691
C80	CAP MONO 220PF 200V 10% NPO	061342	R62	RES NETWORK 8X47KI	144691
C81	CAP MONO 220PF 200V 10% NPO	061342	R63	RES NETWORK 8X47KI	144691
C90	CAP ELECT 47UF 25V 20% NP	066378	R67	RES FP 10 OHM 5% 1/4W	137105
C91	CAP ELECT 47UF 25V 20% NP	066378	R75	RES NET 2 X 22K ISOLATED	144689
D5	DIODE SIL SIGNAL 400MA	070098	R76	RES FP 10 OHM 5% 1/4W	137105
D6	DIODE SIL SIGNAL 400MA	070098	R77	RES MF 1K 1% 1/4W	144513
IC1	IC SPST QUAD FET SWITCHES N O	133426	R80	RES FP 10 OHM 5% 1/4W	137105
IC2	IC SPST QUAD FET SWITCHES N O	133426	R81	RES FP 10 OHM 5% 1/4W	137105
IC3	IC SPST QUAD FET SWITCHES N O	133426	R85	RES FP 10 OHM 5% 1/4W	137105
IC4	IC SPST QUAD FET SWITCHES N O	133426	R86	RES MF 10K 1% 1/4W	144504
IC5	IC SPST QUAD FET SWITCHES N O	133426	R87	RES MF 4.99K 1% 1/4W	144521
IC6	IC SPST QUAD FET SWITCHES N O	133426	R88	RES FP 10 OHM 5% 1/4W	137105
IC9	IC SPST QUAD FET SWITCHES N O	133426	R89	RES MF 4.99K 1% 1/4W	144521
IC10	IC SPST QUAD FET SWITCHES N O	133426	R90	RES MF 75 OHM 1% 1/4W	144644
IC20	IC SHFT REG SER-PAR	133186	R91	RES MF 75 OHM 1% 1/4W	144644
IC21	IC SHFT REG SER-PAR	133186	R92	RES MF 806 OHM 1% 1/4W	144512
IC22	IC SHFT REG SER-PAR	133186	R93	RES MF 806 OHM 1% 1/4W	144512
IC30	IC SHFT REG SER-PAR	133186	R94	RES MF 10K 1% 1/4W	144504
IC31	IC SHFT REG SER-PAR	133186	R95	RES MF 806 OHM 1% 1/4W	144512
J1	JACK S-VIDEO 3X1 14MM	117779	R96	RES MF 10K 1% 1/4W	144504
J2	JACK S-VIDEO 3X1 14MM	117779	R97	RES MF 806 OHM 1% 1/4W	144512
J5	JACK S-VIDEO 3X1 14MM	117779	SP1	BRACKET PCB CARD MOUNTING	003611
J20	CONN MALE 10 POS RIGHT ANGLE	117260	SP2	BRACKET PCB CARD MOUNTING	003611
J23	CONN MALE 6 POS FRICTION LOCK	117218	U14	IC 100MA I FEEDBACK AMP	133286
J25	CONN 4 PIN	117215	U15	IC 100MA I FEEDBACK AMP	133286
Q1	TRANSISTOR NPN SILICON	132317	U16	IC 100MA I FEEDBACK AMP	133286
R1	RES MF 75 OHM 1% 1/4W	144644		SCREW MACH 6-32X1/4 PHL PN	100186
R2	RES MF 75 OHM 1% 1/4W	144644		NUT KEP 6-32 SPECIAL	102045
R3	RES MF 75 OHM 1% 1/4W	144644			

PARTS LIST Con't

6 VIDEO PCB 050165

Ref. No.	Description	Part No.
BRKT1	BRACKET PCB CARD MOUNTING	003611
(BRKT1)	SCREW MACH 6-32X1/4 PHL PN	100186
(BRKT1)	NUT KEP 6-32 SPECIAL	102045
BRKT2	BRACKET PCB CARD MOUNTING	003611
(BRKT2)	SCREW MACH 6-32X1/4 PHL PN	100186
(BRKT2)	NUT KEP 6-32 SPECIAL	102045
C5	CAP ELECT 10UF 50V	066445
C6	CAP ELECT 10UF 50V	066445
C7	CAP ELECT 10UF 50V	066445
C8	CAP ELECT 10UF 50V	066445
C11	CAP MONO .1UF 50V 20% Z5U	061346
C13	CAP MONO .1UF 50V 20% Z5U	061346
C14	CAP MONO .1UF 50V 20% Z5U	061346
C16	CAP MONO .1UF 50V 20% Z5U	061346
C18	CAP MONO .1UF 50V 20% Z5U	061346
C19	CAP MONO .1UF 50V 20% Z5U	061346
C20	CAP MONO .1UF 50V 20% Z5U	061346
C22	CAP MONO .1UF 50V 20% Z5U	061346
C23	CAP MONO .1UF 50V 20% Z5U	061346
C24	CAP MONO .1UF 50V 20% Z5U	061346
C26	CAP MONO .1UF 50V 20% Z5U	061346
C30	CAP MONO .1UF 50V 20% Z5U	061346
C31	CAP MONO .1UF 50V 20% Z5U	061346
C32	CAP MONO .1UF 50V 20% Z5U	061346
C33	CAP MONO .1UF 50V 20% Z5U	061346
C35	CAP ELECT 47UF 50V	066215
C36	CAP ELECT 47UF 50V	066215
C37	CAP ELECT 47UF 50V	066215
C38	CAP ELECT 47UF 50V	066215
C39	CAP ELECT 47UF 50V	066215
C42	CAP ELECT 47UF 50V	066215
C43	CAP ELECT 47UF 25V 20% NP	066378
C44	CAP ELECT 47UF 25V 20% NP	066378
C46	CAP ELECT 47UF 25V 20% NP	066378
C48	CAP MONO .1UF 50V 20% Z5U	061346
C50	CAP MONO .1UF 50V 20% Z5U	061346
C51	CAP MONO .1UF 50V 20% Z5U	061346
C55	CAP MONO .1UF 50V 20% Z5U	061346
C83	CAP MONO 220PF 200V 10% NPO	061342
D1	DIODE SIL SIGNAL 400MA	070098
D2	DIODE SIL SIGNAL 400MA	070098
IC2	IC SPST QUAD FET SWITCHES N O	133426
IC3	IC SPST QUAD FET SWITCHES N O	133426
IC4	IC SPST QUAD FET SWITCHES N O	133426
IC7	IC SPST QUAD FET SWITCHES N O	133426
IC8	IC SHFT REG SER-PAR	133186
IC9	IC 100MA I FEEDBACK AMP	133286
IC10	IC 100MA I FEEDBACK AMP	133286
IC13	IC SHFT REG SER-PAR	133186
IC14	IC SHFT REG SER-PAR	133186
IC15	IC SHFT REG SER-PAR	133186
IC16	IC SPST QUAD FET SWITCHES N O	133426
IC17	IC SHFT REG SER-PAR	133186
IC19	IC NAND SCHMIT 2-IN X 4	133192
J1	JACK RCA 3X1 YELLOW 14MM	117777
J2	JACK RCA 3X1 YELLOW 14MM	117777
J5	JACK RCA 3X1 YELLOW 14MM	117777
J10	CONN 4 PIN	117215
J20	CONN MALE 12 POS ASSY	117220
PCB1	PC BD VIDEO	129507

Ref. No.	Description	Part No.
R2	RES MF 10K 1% 1/4W	144504
R3	RES MF 75 OHM 1% 1/4W	144644
R5	RES MF 75 OHM 1% 1/4W	144644
R9	RES MF 10K 1% 1/4W	144504
R10	RES MF 806 OHM 1% 1/4W	144512
R11	RES MF 75 OHM 1% 1/4W	144644
R12	RES MF 806 OHM 1% 1/4W	144512
R13	RES MF 75 OHM 1% 1/4W	144644
R14	RES MF 75 OHM 1% 1/4W	144644
R15	RES MF 75 OHM 1% 1/4W	144644
R16	RES MF 806 OHM 1% 1/4W	144512
R17	RES MF 75 OHM 1% 1/4W	144644
R18	RES MF 806 OHM 1% 1/4W	144512
R19	RES MF 10K 1% 1/4W	144504
R21	RES MF 806 OHM 1% 1/4W	144512
R22	RES MF 806 OHM 1% 1/4W	144512
R23	RES MF 75 OHM 1% 1/4W	144644
R24	RES MF 806 OHM 1% 1/4W	144512
R25	RES MF 75 OHM 1% 1/4W	144644
R26	RES MF 806 OHM 1% 1/4W	144512
R27	RES MF 10K 1% 1/4W	144504
R28	RES MF 75 OHM 1% 1/4W	144644
R29	RES FP 10 OHM 5% 1/4W	137105
R30	RES NETWORK 8X47KI	144691
R31	RES NETWORK 8X47KI	144691
R32	RES FP 10 OHM 5% 1/4W	137105
R33	RES FP 10 OHM 5% 1/4W	137105
R34	RES FP 10 OHM 5% 1/4W	137105
R35	RES FP 10 OHM 5% 1/4W	137105
R55	RES FP 10 OHM 5% 1/4W	137105
R56	RES MF 4.99K 1% 1/4W	144521
R57	RES FP 10 OHM 5% 1/4W	137105
R58	RES MF 4.99K 1% 1/4W	144521
R60	RES NETWORK 8X47KI	144691
R61	RES NETWORK 3X22K ISO	144682
R91	RES MF 1.1K 1% 1/4W	144514

7 INPUT PCB 050163

Ref. No.	Description	Part No.
C1	CAP ELECT 10UF 50V	066445
C2	CAP ELECT 10UF 50V	066445
C3	CAP ELECT 10UF 50V	066445
C4	CAP ELECT 10UF 50V	066445
C5	CAP MONO .1UF 50V 20% Z5U	061346
C6	CAP MONO .1UF 50V 20% Z5U	061346
C7	CAP MONO .1UF 50V 20% Z5U	061346
C8	CAP MONO .1UF 50V 20% Z5U	061346
C9	CAP ELECT 10UF 16V	066580
C10	CAP ELECT 4.7UF 50V	066512
C11	CAP ELECT 1UF 50V	066510
C12	CAP MONO 100PF 100V 10% NPO	061341
C13	CAP MONO 100PF 100V 10% NPO	061341
C14	CAP MONO 100PF 100V 10% NPO	061341
C15	CAP MONO .1UF 50V 20% Z5U	061346
C16	CAP MONO .1UF 50V 20% Z5U	061346
C17	CAP MONO .1UF 50V 20% Z5U	061346
C18	CAP MONO .1UF 50V 20% Z5U	061346
C19	CAP MONO .1UF 50V 20% Z5U	061346
C20	CAP MONO .1UF 50V 20% Z5U	061346
C21	CAP MONO .1UF 50V 20% Z5U	061346
C22	CAP MONO .1UF 50V 20% Z5U	061346

PARTS LIST Con't

INPUT PCB 050163 (Cont'd.)

Ref. No.	Description	Part No.	Ref. No.	Description	Part No.
C23	CAP MONO .1UF 50V 20% Z5U	061346	C106	CAP ELECT 10UF 16V	066580
C24	CAP MONO .1UF 50V 20% Z5U	061346	C112	CAP ELECT 10UF 16V	066580
C25	CAP MONO .1UF 50V 20% Z5U	061346	C114	CAP ELECT 10UF 16V	066580
C26	CAP MONO .1UF 50V 20% Z5U	061346	C115	CAP ELECT 10UF 16V	066580
C29	CAP MONO .1UF 50V 20% Z5U	061346	C116	CAP ELECT 10UF 16V	066580
C30	CAP MONO .1UF 50V 20% Z5U	061346	C118	CAP MONO .1UF 50V 20% Z5U	061346
C31	CAP MONO .1UF 50V 20% Z5U	061346	C119	CAP MONO .1UF 50V 20% Z5U	061346
C34	CAP MONO 100PF 100V 10% NPO	061341	C130	CAP ELECT 10UF 16V	066580
C35	CAP ELECT 470UF 16V	066508	C131	CAP ELECT 10UF 16V	066580
C36	CAP MONO .1UF 50V 20% Z5U	061346	C132	CAP ELECT 10UF 16V	066580
C37	CAP ELECT 10UF 50V	066445	C134	CAP ELECT 10UF 16V	066580
C38	CAP ELECT 10UF 50V	066445	C144	CAP ELECT 10UF 16V	066580
C39	CAP MONO .1UF 50V 20% Z5U	061346	C145	CAP ELECT 10UF 16V	066580
C41	CAP MONO 100PF 100V 10% NPO	061341	C151	CAP MONO .1UF 50V 20% Z5U	061346
C40	CAP MONO 47PF 200V 10% NPO	061340	D1	DIODE SILICON	070174
C42	CAP MONO .1UF 50V 20% Z5U	061346	D2	DIODE SILICON	070174
C43	CAP ELECT 470UF 16V	066508	D4	DIODE SILICON	070174
C44	CAP ELECT 10UF 16V	066580	D5	DIODE SILICON	070174
C45	CAP MONO 47PF 200V 10% NPO	061340	D6	DIODE SILICON	070174
C46	CAP ELECT 10UF 16V	066580	D7	DIODE SILICON	070174
C47	CAP MONO 100PF 100V 10% NPO	061341	IC1	IC SPST QUAD FET SWITCHES N O	133426
C48	CAP ELECT 10UF 16V	066580	IC2	IC SPST QUAD FET SWITCHES N O	133426
C49	CAP MONO .1UF 50V 20% Z5U	061346	IC3	IC SPST QUAD FET SWITCHES N O	133426
C50	CAP ELECT 10UF 16V	066580	IC4	IC SPST QUAD FET SWITCHES N O	133426
C51	CAP MPF 0.033UF 5% 63VDC	064318	IC5	IC SPST QUAD FET SWITCHES N O	133426
C52	CAP MPF 0.033UF 5% 63VDC	064318	IC6	IC SPST QUAD FET SWITCHES N O	133426
C53	CAP MONO .1UF 50V 20% Z5U	061346	IC7	IC SPST QUAD FET SWITCHES N O	133426
C54	CAP ELECT 10UF 16V	066580	IC8	IC SPST QUAD FET SWITCHES N O	133426
C55	CAP MONO .1UF 50V 20% Z5U	061346	IC13	IC SHFT REG SER-PAR	133186
C56	CAP MONO 100PF 100V 10% NPO	061341	IC14	IC SHFT REG SER-PAR	133186
C57	CAP MPF 0.01UF 5% 63VDC	064312	IC16	IC SPST QUAD FET SWITCHES N O	133426
C58	CAP MPF 0.01UF 5% 63VDC	064312	IC17	IC OPERATIONAL AMPLIFIER	133189
C59	CAP MONO .1UF 50V 20% Z5U	061346	IC18	IC SPST QUAD FET SWITCHES N O	133426
C60	CAP MONO .1UF 50V 20% Z5U	061346	IC19	IC OPERATIONAL AMPLIFIER	133189
C61	CAP ELECT 10UF 16V	066580	IC20	IC OPERATIONAL AMPLIFIER	133189
C62	CAP ELECT 10UF 16V	066580	IC21	IC OPERATIONAL AMPLIFIER	133189
C63	CAP MONO 100PF 100V 10% NPO	061341	IC22	IC OPERATIONAL AMPLIFIER	133189
C64	CAP ELECT 10UF 50V	066445	IC23	IC OPERATIONAL AMPLIFIER	133189
C65	CAP ELECT 10UF 16V	066580	IC24	IC OPERATIONAL AMPLIFIER	133189
C66	CAP MONO 100PF 100V 10% NPO	061341	IC32	IC OPERATIONAL AMPLIFIER	133189
C67	CAP MONO 100PF 100V 10% NPO	061341	IC33	IC OPERATIONAL AMPLIFIER	133189
C73	CAP ELECT 10UF 50V	066445	IC34	IC SHFT REG SER-PAR	133186
C69	CAP MONO 100PF 100V 10% NPO	061341	IC35	IC SHFT REG SER-PAR	133186
C70	CAP MONO 220PF 200V 10% NPO	061342	IC38	IC SPST QUAD FET SWITCHES N O	133426
C71	CAP MONO .1UF 50V 20% Z5U	061346	IC39	IC SPST QUAD FET SWITCHES N O	133426
C72	CAP MONO 100PF 100V 10% NPO	061341	J1	JACK RCA 2X2 WHT/RED 14MM	117789
C74	CAP ELECT 10UF 50V	066445	J1	CONN SUB D MINIATURE 37PIN	117550
C75	CAP ELECT 10UF 50V	066445	J2	JACK RCA 3X2 WHT/RED 14MM	117790
C76	CAP ELECT 10UF 50V	066445	J3	JACK RCA 3X2 WHT/RED 14MM	117790
C77	CAP ELECT 10UF 50V	066445	J4	JACK RCA 2X2 WHT/RED 14MM	117789
C78	CAP ELECT 10UF 50V	066445	J5	CONN XLR FEM HORIZ PCB LATCH	117814
C79	CAP MONO .1UF 50V 20% Z5U	061346	J6	CONN MALE 9 POS FRICTION LOCK	117244
C80	CAP MONO .1UF 50V 20% Z5U	061346	J7	CONN XLR FEM HORIZ PCB LATCH	117814
C81	CAP ELECT 10UF 50V	066445	J8	CONN 4 PIN	117215
C82	CAP ELECT 10UF 50V	066445	J9	CONN MALE 10 POS	117219
C83	CAP ELECT 10UF 50V	066445	J10	RECEPTACLE XLR MALE	117686
C84	CAP ELECT 10UF 50V	066445	J11	RECEPTACLE XLR MALE	117686
C85	CAP MONO .1UF 50V 20% Z5U	061346	J12	RECEPTACLE XLR MALE	117686
C98	CAP ELECT 10UF 16V	066580	J20	CONN 3 POS MALE MTS100 NORMAL	117214
C104	CAP ELECT 10UF 16V	066580	J21	CONN 8 POS MALE FRICTION LOCK	117275

PARTS LIST Con't

INPUT PCB 050163 (Cont'd.)

Ref. No.	Description	Part No.	Ref. No.	Description	Part No.
J23	CONN 11 POS MALE	117279	R56	RES MF 22.1K 1% 1/4W	144564
K19	RELAY REED FORM 1A 5V 500 OHMS	087050	R57	RES MF 20K 1% 1/4W	144524
K20	RELAY REED FORM 1A 5V 500 OHMS	087050	R58	RES MF 20K 1% 1/4W	144524
K22	RELAY REED FORM 1A 5V 500 OHMS	087050	R59	RES MF 100 OHM 1% 1/4W	144568
PCB1	PC BD INPUT	129583	R60	RES MF 100 OHM 1% 1/4W	144568
Q1	TRANSISTOR PNP	132304	R61	RES MF 20K 1% 1/4W	144524
Q2	TRANSISTOR NPN 2K/REEL	132317	R62	RES MF 100 OHM 1% 1/4W	144568
Q3	TRANSISTOR NPN 2K/REEL	132317	R63	RES MF 20K 1% 1/4W	144524
R1	RES MF 100K 1% 1/4W	144528	R64	RES MF 100 OHM 1% 1/4W	144568
R3	RES MF 10K 1% 1/4W	144504	R65	RES MF 100 OHM 1% 1/4W	144568
R5	RES NETWORK 8X100 ISO	144683	R66	RES MF 22.1K 1% 1/4W	144564
R6	RES NETWORK 8X100 ISO	144683	R68	RES MF 221K 1/4W 1%	144629
R7	RES MF 1K 1% 1/4W	144513	R69	RES MF 221K 1/4W 1%	144629
R8	RES MF 1K 1% 1/4W	144513	R71	RES NET 2 X 22K ISOLATED	144689
R9	RES MF 20K 1% 1/4W	144524	R77	RES NET 3 X 100K OHM ISOLATED	144501
R10	RES NETWORK 8X47KI	144691	R78	RES NETWORK 2X100 OHM ISOLATED	144680
R11	RES NETWORK 8X47KI	144691	R79	RES NET 2 X 22K ISOLATED	144689
R12	RES NETWORK 8X47KI	144691	R89	RES NETWORK 2X100 OHM ISOLATED	144680
R13	RES NETWORK 8X47KI	144691	R110	RES MF 1K 1% 1/4W	144513
R14	RES MF 95.3 OHM 1% 1/4W	144572	R111	RES FP 10 OHM 5% 1/4W	137105
R15	RES MF 95.3 OHM 1% 1/4W	144572	R112	RES FP 10 OHM 5% 1/4W	137105
R16	RES MF 47.5K 1% 1/4W	144526	R113	RES FP 10 OHM 5% 1/4W	137105
R17	RES MF 7.5K 1% 1/4W	144571	R114	RES FP 10 OHM 5% 1/4W	137105
R18	RES MF 7.5K 1% 1/4W	144571	R115	RES FP 10 OHM 5% 1/4W	137105
R19	RES MF 47.5K 1% 1/4W	144526	R86	RES NET 2 X 22K ISOLATE	144689
R20	RES FP 10 OHM 5% 1/4W	137105	U1	IC DUAL OPERATIONAL AMPLIFIER	133260
R21	RES MF 95.3K 1% 1/4W	144538	U2	IC OPERATIONAL AMP LOW NOISE	133067
R22	RES MF 2.21 OHM 1/4W 1%	144607	U3	IC OPERATIONAL AMP LOW NOISE	133067
R23	RES MF 95.3K 1% 1/4W	144538	U4	IC 3-8 LINE DEC LATCH	133170
R24	RES MF 2.21 OHM 1/4W 1%	144607	U6	IC DUAL OPERATIONAL AMPLIFIER	133260
R25	RES MF 2.21 OHM 1/4W 1%	144607	U7	IC DUAL OPERATIONAL AMPLIFIER	133260
R26	RES MF 221 OHM 1% 1/4W	144559	X_116	CAP ELECT 10UF 16V	066580
R27	RES MF 221 OHM 1% 1/4W	144559	X_117	CAP ELECT 10UF 16V	066580
R28	RES MF 2.21 OHM 1/4W 1%	144607			
R29	RES MF 47.5K 1% 1/4W	144526			
R30	RES MF 10K 1% 1/4W	144504			
R31	RES MF 20K 1% 1/4W	144524			
R32	RES MF 20K 1% 1/4W	144524			
R33	RES MF 10K 1% 1/4W	144504			
R34	RES MF 20K 1% 1/4W	144524			
R35	RES MF 10K 1% 1/4W	144504			
R36	RES MF 10K 1% 1/4W	144504			
R37	RES NETWORK 2X220K ISO	144678			
R38	RES MF 221K 1/4W 1%	144629			
R39	RES NET 2 X 22K ISOLATED	144689			
R40	RES MF 20K 1% 1/4W	144524			
R41	RES MF 221K 1/4W 1%	144629			
R42	RES MF 20K 1% 1/4W	144524			
R43	RES NET 2 X 22K ISOLATED	144689			
R44	RES MF 221K 1/4W 1%	144629			
R45	RES NET 2 X 22K ISOLATED	144689			
R46	RES MF 100 OHM 1% 1/4W	144568			
R47	RES NET 2 X 22K ISOLATED	144689			
R48	RES MF 100 OHM 1% 1/4W	144568			
R49	RES NET 2 X 22K ISOLATED	144689			
R50	RES NET 2 X 22K ISOLATED	144689			
R51	RES NET 2 X 22K ISOLATED	144689			
R53	RES NET 2 X 22K ISOLATED	144689			
R54	RES MF 221K 1/4W 1%	144629			
R55	RES MF 100 OHM 1% 1/4W	144568			



8 COMPONENT VIDEO PCB 050180

BRKT1	BRACKET PCB CARD MOUNTING	003611
(BRKT1)	SCREW MACH 6-32X1/4 PHL PN	100186
(BRKT1)	NUT KEP 6-32 SPECIAL	102045
IC1	CAP MPF 0.047UF 5% 63VDC	064320
C2	CAP MPF 0.047UF 5% 63VDC	064320
C3	CAP MPF 0.047UF 5% 63VDC	064320
C4	CAP ELECT 10UF 50V	066445
C5	CAP MONO 220PF 200V 10% NPO	061342
C6	CAP MPF 0.047UF 5% 63VDC	064320
C7	CAP MPF 0.047UF 5% 63VDC	064320
C8	CAP MPF 0.047UF 5% 63VDC	064320
C9	CAP MPF 0.047UF 5% 63VDC	064320
C10	CAP ELECT 47UF 25V 20% NP	066378
C11	CAP ELECT 47UF 25V 20% NP	066378
C12	CAP MPF 0.047UF 5% 63VDC	064320
C13	CAP MPF 0.047UF 5% 63VDC	064320
C14	CAP MPF 0.047UF 5% 63VDC	064320
C15	CAP MPF 0.047UF 5% 63VDC	064320
C16	CAP MPF 0.068UF 5% 63VDC	064323
C17	CAP MPF 0.047UF 5% 63VDC	064320
C19	CAP ELECT 470UF 16V	066508
C20	CAP ELECT 470UF 16V	066508
C27	CAP MONO 390PF 5% 200V	061352
C22	CAP MONO 120PF 5% 200V	061351
C23	CAP MONO 560PF 200V 5% NPO	061348

PARTS LIST Con't

COMPONENT VIDEO PCB 050180 (Cont'd.)

Ref. No.	Description	Part No.	Ref. No.	Description	Part No.
C24	CAP MONO 390PF 5% 200V	061352	IC10	IC 100MA I FEEDBACK AMP	133286
C25	CAP MONO 120PF 5% 200V	061351	IC12	IC 100MA I FEEDBACK AMP	133286
C26	CAP MONO 560PF 200V 5% NPO	061348	IC13	IC 100MA I FEEDBACK AMP	133286
C27	CAP MONO 390PF 5% 200V	061352	IC15	IC REGULATOR 3.3V LOW DROPOUT	133393
C28	CAP MONO 120PF 5% 200V	061351	IC22	IC SHFT REG SER-PAR	133186
C29	CAP MONO 560PF 200V 5% NPO	061348	IC36	IC REGULATOR +5V	133108
C30	CAP ELECT 47UF 25V 20% NP	066378	(IC36)	HEATSINK T0220	080014
C31	CAP MONO .1UF 50V 20% Z5U	061346	J4	CONN MALE 7 PIN	117217
C32	CAP MONO .1UF 50V 20% Z5U	061346	J5	CONN HEADER 10 POS	117333
C33	CAP MONO .1UF 50V 20% Z5U	061346	J6	CONN 2 PIN MALE	117213
C34	CAP MONO .1UF 50V 20% Z5U	061346	J7	CONN 4 PIN	117215
C35	CAP ELECT 47UF 25V 20% NP	066378	J8	CONN MALE 6 POS FRICTION LOCK	117218
C36	CAP MONO .1UF 50V 20% Z5U	061346	J9	CONN 2 PIN MALE	117213
C37	CAP MONO .1UF 50V 20% Z5U	061346	J17	RCA JACK 2 X 3 RBG	117840
C40	CAP ELECT 47UF 25V 20% NP	066378	J19	RCA JACK 2 X 3 RBG	117840
C41	CAP ELECT 47UF 25V 20% NP	066378	J21	CONN MALE 12 POS ASSY	117220
C42	CAP MONO .1UF 50V 20% Z5U	061346	J20	CONN MALE 10 POS RIGHT ANGLE	117260
C43	CAP ELECT 47UF 25V 20% NP	066378	L1	BEADS FERRITE LEADED	076023
C44	CAP ELECT 10UF 50V	066445	L2	BEADS FERRITE LEADED	076023
C45	CAP MONO .1UF 50V 20% Z5U	061346	L3	CHOKE RF 3.3UH 10%	122229
C46	CAP ELECT 10UF 50V	066445	L4	CHOKE RF 3.3UH 10%	122229
C47	CAP MONO .1UF 50V 20% Z5U	061346	L5	CHOKE RF 3.3UH 10%	122229
C48	CAP MONO .1UF 50V 20% Z5U	061346	L6	CHOKE RF 3.3UH 10%	122229
C49	CAP ELECT 47UF 25V 20% NP	066378	L7	CHOKE 8.2UF 5% CC	122235
C50	CAP MONO 220PF 200V 10% NPO	061342	L8	CHOKE RF 3.3UH 10%	122229
C61	CAP MONO .1UF 50V 20% Z5U	061346	L9	CHOKE RF 3.3UH 10%	122229
C62	CAP ELECT 10UF 50V	066445	L10	BEADS FERRITE LEADED	076023
C63	CAP MONO .1UF 50V 20% Z5U	061346	L11	CHOKE RF 3.3UH 10	122229
C64	CAP ELECT 10UF 50V	066445	L12	CHOKE RF 3.3UH 10%	122229
C67	CAP MONO 22PF 200V 10% NPO	061339	L13	CHOKE 8.2UF 5% CC	122235
C68	CAP MONO 1000PF 50V 10% NPO	061344	L18	INDUCTOR 2.7UH	122355
C69	CAP MONO 10PF 200V 10% NPO	061338	L19	INDUCTOR 2.7UH	122355
C70	CAP MONO 10PF 200V 10% NPO	061338	L20	INDUCTOR 2.7UH	122355
C71	CAP MONO 22PF 200V 10% NPO	061339	L21	INDUCTOR 2.7UH	122355
C72	CAP MONO 22PF 200V 10% NPO	061339	L22	INDUCTOR 2.7UH	122355
C73	CAP MONO .1UF 50V 20% Z5U	061346	L23	INDUCTOR 2.7UH	122355
C75	CAP MONO .1UF 50V 20% Z5U	061346	Q4	IC VOLTAGE REGULATOR -5.2V	133088
C76	CAP MONO .1UF 50V 20% Z5U	061346	(Q4)	HEATSINK T0220	080014
C77	CAP MONO .1UF 50V 20% Z5U	061346	R1	RES MF 18.2 OHM 1/4W 1%	144659
C78	CAP MONO .1UF 50V 20% Z5U	061346	R2	RES MF 4.75K 1% 1/4W	144520
C79	CAP MONO 33PF 200V 5%NPO	061347	R5	RES NETWORK 8X330 ISO	144679
C80	CAP MONO 33PF 200V 5%NPO	061347	R9	RES MF 10K 1% 1/4W	144504
C110	CAP MONO .1UF 50V 20% Z5U	061346	R10	RES MF 10K 1% 1/4W	144504
C111	CAP MONO .1UF 50V 20% Z5U	061346	R11	RES MF 10K 1% 1/4W	144504
C112	CAP MONO .1UF 50V 20% Z5U	061346	R14	RES MF 806 OHM 1% 1/4W	144512
C113	CAP MONO .1UF 50V 20% Z5U	061346	R15	RES MF 806 OHM 1% 1/4W	144512
C114	CAP MONO .1UF 50V 20% Z5U	061346	R17	RES CF 75 OHM 5% 1/8W	141264
C115	CAP MONO .1UF 50V 20% Z5U	061346	R18	RES CF 75 OHM 5% 1/8W	141264
C116	CAP MONO .1UF 50V 20% Z5U	061346	R19	RES CF 75 OHM 5% 1/8W	141264
C117	CAP MONO .1UF 50V 20% Z5U	061346	R20	RES MF 75 OHM 1% 1/4W	144644
C118	CAP MONO .1UF 50V 20% Z5U	061346	R22	RES MF 75 OHM 1% 1/4W	144644
C119	CAP MONO .1UF 50V 20% Z5U	061346	R23	RES MF 75 OHM 1% 1/4W	144644
C170	CAP ELECT 100UF 25V	066573	R24	RES MF 22.1K 1% 1/4W	144564
C174	CAP ELECT 100UF 25V	066573	R25	RES MF 75 OHM 1% 1/4W	144644
HS1	HEATSINK T0220	080014	R26	RES MF 806 OHM 1% 1/4W	144512
C5	IC: PROG VIDEO CPLD 133406	133519	R27	RES MF 75 OHM 1% 1/4W	144644
IC2	IC COMP VIDEO IMPUT PROCESSOR	133434	R28	RES MF 4.75 OHM 1/4W 1%	144658
IC3	IC DIGITAL VIDEO ENCODER	133435	R29	RES MF 22.1 OHM 1% 1/4W	144554
(IC5)	SOCKET IC PLCC 84 PIN	178174	R30	RES MF 10K 1% 1/4W	144504
IC9	IC 100MA I FEEDBACK AMP	133286	R31	RES MF 10 OHM 1% 1/4W	144553

PARTS LIST Con't

COMPONENT VIDEO PCB 050180 (Cont'd.)

Ref. No.	Description	Part No.	Ref. No.	Description	Part No.
R32	RES MF 10 OHM 1% 1/4W	144553	U2	IC QUAD ANALOG SWITCH HI SPEED	133342
R33	RES MF 22.1 OHM 1% 1/4W	144554	U4	IC MULTIPLEXER TRIPLE 2:1	133513
R34	RES CF 75 OHM 5% 1/8W	141264	U5	IC MULTIPLEXER TRIPLE 2:1	133513
R35	RES MF 18.2 OHM 1/4W 1%	144659	U6	IC MULTIPLEXER TRIPLE 2:1	133513
R36	RES MF 56.2 OHM 1/4W 1%	144660	Y1	CRYSTAL 17.734475MHZ FUND	180062
R37	RES MF 18.2 OHM 1/4W 1%	144659	Y2	CRYSTAL 27MHZ 3RD HARMONIC	180052
R38	RES MF 56.2 OHM 1/4W 1%	144660	Y3	CRYSTAL 24.576MHZ	180045
R39	RES MF 18.2 OHM 1/4W 1%	144659	Y4	CRYSTAL 14.31818MHZ FUND	180061
R40	RES MF 56.2 OHM 1/4W 1%	144660			
R41	RES MF 18.2 OHM 1/4W 1%	144659			
R42	RES MF 56.2 OHM 1/4W 1%	144660			
R43	RES MF 18.2 OHM 1/4W 1%	144659			
R44	RES MF 56.2 OHM 1/4W 1%	144660			
R45	RES MF 18.2 OHM 1/4W 1%	144659			
R46	RES MF 56.2 OHM 1/4W 1%	144660			
R47	RES CF 75 OHM 5% 1/8W	141264			
R48	RES CF 75 OHM 5% 1/8W	141264			
R49	RES CF 75 OHM 5% 1/8W	141264			
R50	RES MF 1.1K 1% 1/4W	144514			
R51	RES CF 75 OHM 5% 1/8W	141264			
R52	RES CF 75 OHM 5% 1/8W	141264			
R53	RES MF 100K 1% 1/4W	144528			
R54	RES MF 10K 1% 1/4W	144504			
R55	RES MF 10 OHM 1% 1/4W	144553			
R56	RES CF 75 OHM 5% 1/8W	141264			
R57	RES CF 75 OHM 5% 1/8W	141264			
R58	RES CF 75 OHM 5% 1/8W	141264			
R60	RES FP 10 OHM 5% 1/4W	137105			
R61	RES MO 4.7 OHM 1W 5%	144656			
R62	RES MO 4.7 OHM 1W 5%	144656			
R63	RES MF 806 OHM 1% 1/4W	144512			
R65	RES MF 4.75K 1% 1/4W	144520			
R66	RES MF 4.75K 1% 1/4W	144520			
R68	RES CF 75 OHM 5% 1/8W	141264			
R69	RES CF 75 OHM 5% 1/8W	141264			
R70	RES MF 10K 1% 1/4W	144504			
R71	RES MF 10K 1% 1/4W	144504			
R72	RES MF 10K 1% 1/4W	144504			
R73	RES MF 806 OHM 1% 1/4W	144512			
R74	RES MF 806 OHM 1% 1/4W	144512			
R75	RES MF 10K 1% 1/4W	144504			
R76	RES MF 806 OHM 1% 1/4W	144512			
R77	RES MF 806 OHM 1% 1/4W	144512			
R78	RES MF 75 OHM 1% 1/4W	144644			
R79	RES MF 75 OHM 1% 1/4W	144644			
R80	RES MF 75 OHM 1% 1/4W	144644			
R84	RES CF 75 OHM 5% 1/8W	141264			
R85	RES CF 75 OHM 5% 1/8W	141264			
R86	RES CF 75 OHM 5% 1/8W	141264			
R87	RES CF 75 OHM 5% 1/8W	141264			
R88	RES MF 100K 1% 1/4W	144528			
R89	RES MF 4.75K 1% 1/4W	144520			
R90	RES MF 4.75K 1% 1/4W	144520			
R91	RES MF 10K 1% 1/4W	144504			
R92	RES MF 10K 1% 1/4W	144504			
R94	RES CF 0 OHM 5% 1/4W	141554			
R96	RES CF 0 OHM 5% 1/4W	141554			
R98	RES MF 56.2 OHM 1/4W 1%	144660			
R99	RES MF 18.2 OHM 1/4W 1%	144659			
U1	IC GENERATOR OSD	133512			

9

10

TUNER/RAA1 SECTION PCB 049084

	TUNER CHASSIS	005251
	FM FRONT END ENCLOSURE	005252
	FM RF SHIELD	005253
	SPACER .380ID 3/8L PHENOLIC	017673
C1	MONO CAP 0.1MF 20% 50V	061328
C2	MONO CAP: 100PF, 5%, 100V, NPO	061327
C3	MONO CAP 10PF 10% 100V	061288
C4	MONO CAP 0.1MF 20% 50V	061328
C5	CAP MONO .0022UF 5% 100V NPO	061335
C6	MONO CAP: 100PF, 5%, 100V, NPO	061327
C7	MONO CAP 0.1MF 20% 50V	061328
C8	CAP MONO 22PF 5% 100V NPO	061331
C9	MONO CAP 10PF 10% 100V	061288
C10	MONO CAP .047UF 10% 50V X7R	061334
C11	MONO CAP 0.1MF 20% 50V	061328
C12	MONO CAP: 100PF, 5%, 100V, NPO	061327
C13	MONO CAP .047UF 10% 50V X7R	061334
C14	MONO CAP: 100PF, 5%, 100V, NPO	061327
C15	MONO CAP .047UF 10% 50V X7R	061334
C16	MONO CAP .047UF 10% 50V X7R	061334
C17	MONO CAP: 100PF, 5%, 100V, NPO	061327
C18	MONO CAP .047UF 10% 50V X7R	061334
C19	MONO CAP 0.1MF 20% 50V	061328
C20	MONO CAP 0.1MF 20% 50V	061328
C21	CAP MONO CER 360PF 5% 100V	061257
C22	MONO CAP 10PF 10% 100V	061288
C23	CAP MONO .0022UF 5% 100V NPO	061335
C24	CAP MONO 22PF 5% 100V NPO	061331
C25	CAP MONO .0022UF 5% 100V NPO	061335
C26	MONO CAP 0.1MF 20% 50V	061328
C27	MONO CAP 0.1MF 20% 50V	061328
C28	MONO CAP .047UF 10% 50V X7R	061334
C29	MONO CAP 0.1MF 20% 50V	061328
C30	MONO CAP 0.1MF 20% 50V	061328
C31	CAP MONO .0022UF 5% 100V NPO	061335
C32	MONO CAP 10PF 10% 100V	061288
C33	MONO CAP .047UF 10% 50V X7R	061334
C34	MONO CAP 0.1MF 20% 50V	061328
C35	DISC CAP: 1.8PF+/- .25PF NPO	061002
C36	M POLY CAP: .015UF, 5%, 63V DC	064314
C37	M POLY CAP: .033UF, 5%, 63V DC	064318
C38	M POLY CAP: .047UF, 5%, 63V DC	064320
C39	M.CAP: 470PF, 5%, 100V	061321
C40	M POLY CAP: .015UF, 5%, 63V DC	064314
C41	M POLY CAP: .033UF, 5%, 63V DC	064318
C42	M POLY CAP: .033UF, 5%, 63V DC	064318
C43	M POLY CAP: .033UF, 5%, 63V DC	064318
C45	CAP ELECT 10UF 50V	066445
C46	CAP ELECT 10UF 50V	066445

PARTS LIST Con't

TUNER/RAA1 SECTION PCB 049084 (Cont'd.)

Ref. No.	Description	Part No.	Ref. No.	Description	Part No.
C47	CAP ELECT 10UF 50V	066445	J1	GOLD F CONNECTOR RIGHT ANGLE	117661
C48	CAP ELECT 10UF 50V	066445	(J1)	LK WASH:3/8X.507X.002 INT STAR	104014
C49	CAP ELECT 10UF 50V	066445	J2	DIN CONN 7-PIN	117383
C50	DISC CAP:.47UF 50V MONOLITHIC	061320	J3	MALE CONN:6 PIN RT. ANGLE	117223
C51	CAP ELECT 10UF 50V	066445	J4	CONN, RT.ANGLE, MALE,7 POS	117319
C52	CAP ELECT 10UF 50V	066445	J5	4 PIN RT ANGLE	117240
C53	CAP ELECT 47UF 35V	066446	J6	2-PIN MALE CONNECTOR	117213
C54	CAP ELECT 10UF 50V	066445	J101	HEADER 5 PIN	117677
C55	CAP ELECT 10UF 50V	066445	L1	RF CHOKE:3.3UH, 10%	122229
C56	CAP ELECT 100UF 25V	066573	L2	MIXER COIL	122250
C57	CAP ELECT 1UF 10% 50V	066562	L3	MIXER COIL	122250
C58	CAP ELECT 1UF 10% 50V	066562	L4	ANT. COIL	122249
C59	TRIM CAP:2-10PF	060027	L5	ANT. COIL	122249
C60	TRIM CAP:2-10PF	060027	Q1	TRANSISTOR D MOS FET	132290
C61	3-27PF TRIMMER CAPACITOR	060029	Q2	TRANSISTOR PNP SI	132304
C62	TRIM CAP:2-10PF	060027	Q3	TRANSISTOR NPN	132317
C63	TRIM CAP:2-10PF	060027	Q5	TRANSISTOR NPN	132317
C64	3-27PF TRIMMER CAPACITOR	060029	Q6	TRANSISTOR NPN	132317
C65	3-27PF TRIMMER CAPACITOR	060029	Q7	TRANSISTOR NPN	132317
C67	CAP ELECT 100UF 25V	066573	Q8	TRANSISTOR P FET 1-4PO 250 OHM	132220
C68	CAP ELECT 100UF 25V	066573	Q9	TRANSISTOR PNP SI	132304
C69	CAP ELECT 100UF 25V	066573	Q10	TRANSISTOR NPN	132317
C70	DISC CAP:.47UF 50V	061320	Q11	TRANSISTOR NPN	132317
C71	DISC CAP:.47UF 50V	061320	Q101	TRANSISTOR P FET 1-4PO 250 OHM	132220
C72	DISC CAP:.47UF 50V	061320	Q102	TRANSISTOR:RF FET	132178
C73	CAP MPF 0.22UF 5% 63VDC	064329	Q12	TRANSISTOR NPN	132317
C74	CAP MONO .0022UF 5% 100V NPO	061335	IC1	IC FM FRONT END	133231
C75	MONO CAP .047UF 10% 50V X7R	061334	IC2	AM-FM MPX TUNER IC	133381
C76	CAP MONO 220PF 5% 100V NPO	061273	IC3	IC DIRECT PLL FREQ SYNTHESIZER	133270
C77	CAP MONO 220PF 5% 100V NPO	061273	IC4	IC OPERATIONAL AMPLIFIER	133189
C78	CAP MONO 220PF 5% 100V NPO	061273	IC5	IC OPERATIONAL AMPLIFIER	133189
C79	CAP MONO 220PF 5% 100V NPO	061273	IC6	IC +8V VOLTAGE REGULATOR	133147
C80	M POLY CAP:.022UF, 5%,63V DC	064316	R1	RES MF 10K 1% 1/4W	144504
C81	M POLY CAP:.022UF, 5%,63V DC	064316	R3	RES MF 1K 1% 1/4W	144513
C82	CAP MPF 0.0068UF 5% 63VDC	064310	R4	RES MF 100 OHM 1% 1/4W	144568
C83	CAP MPF 0.0068UF 5% 63VDC	064310	R5	RES MF 1K 1% 1/4W	144513
C102	MONO CAP 0.1MF 20% 50V	061328	R6	RES MF 15K 1% 1/4W	144623
C103	CAP MONO .0022UF 5% 100V NPO	061335	R7	RES MF 1K 1% 1/4W	144513
C104	MONO CAP 0.1MF 20% 50V	061328	R8	RES MF 47.5K 1% 1/4W	144526
C105	MONO CAP 0.1MF 20% 50V	061328	R9	RES MF 47.5K 1% 1/4W	144526
C106	3-27PF TRIMMER CAPACITOR	060029	R10	METAL FILM RES 2.87K 1% 1/4W	144142
D1	DIODE TUNING	070122	R11	RES MF 10K 1% 1/4W	144504
D2	DIODE TUNING	070122	R13	RES MF 47.5K 1% 1/4W	144526
D3	DIODE TUNING	070122	R14	RES MF 100 OHM 1% 1/4W	144568
D4	DIODE TUNING	070122	R15	RES MF 10K 1% 1/4W	144504
D5	DIODE TUNING	070122	R16	RES MF 2.21M 1/4W	144576
D6	DIODE TUNING	070122	R17	RES MF 22.1K 1% 1/4W	144564
D7	DIODE TUNING	070122	R18	RES MF 47.5K 1% 1/4W	144526
D8	DIODE TUNING	070122	R19	RES MF 10K 1% 1/4W	144504
D10	SILICON DIODE	070174	R20	RES MF 15K 1% 1/4W	144623
D11	TUNING DIODE	070125	R21	RES MF 100 OHM 1% 1/4W	144568
D12	TUNING DIODE	070125	R22	RES MF 4.75K 1% 1/4W	144520
D101	TUNING DIODE	070125	R23	RES MF 324 1% 1/4W	144597
D102	SILICON DIODE	070174	R24	RES MF 4.75K 1% 1/4W	144520
D103	SILICON DIODE	070174	R25	METAL FILM RES 2.87K 1% 1/4W	144142
D104	SILICON DIODE	070174	R26	RES MF 324 1% 1/4W	144597
FN1	FILTER CERAMIC 10.7MHZ	180056	R27	RES MF 681K 1% 1/4W	144643
FN2	FILTER CERAMIC 10.7MHZ	180056	R28	RES MF 681K 1% 1/4W	144643
FN3	FILTER CERAMIC 10.7MHZ	180056	R29	RES MF 10K 1% 1/4W	144504
FN6	FILTER 450KHZ	180055	R30	RES MF 1K 1% 1/4W	144513

PARTS LIST Con't

TUNER/RAA1 SECTION PCB 049084 (Cont'd.)

Ref. No.	Description	Part No.	Ref. No.	Description	Part No.
R32	RES MF 4.75K 1% 1/4W	144520	R65	RES MF 221 1% 1/4W	144559
R33	RES MF 4.75K 1% 1/4W	144520	R67	RES MF 22.1OHM 1% 1/4W	144554
R35	RES MF 4.75K 1% 1/4W	144520	R68	RES MF 10K 1% 1/4W	144504
R38	RES MF 1K 1% 1/4W	144513	R69	RES MF 4.75K 1% 1/4W	144520
R39	RES MF 2.21K 1% 1/4W	144584	R70	TRIMPOT 22K	134406
R40	RES MF 15K 1% 1/4W	144623	R71	POTENTIOMETER:10K OHM	134414
R41	RES MF 10K 1% 1/4W	144504	R73	POTENTIOMETER:10K OHM	134414
R42	RES MF 2.21M 1/4W	144576	R74	RES MF 47.5OHM 1% 1/4W	144642
R43	RES MF 4.75K 1% 1/4W	144520	R75	RES MF 10K 1% 1/4W	144504
R44	RES MF 10K 1% 1/4W	144504	R76	RES MF 100K 1% 1/4W	144528
R45	RES MF 4.75K 1% 1/4W	144520	R101	RES MF 10K 1% 1/4W	144504
R46	RES MF 2.21K 1% 1/4W	144584	R102	RES MF 10K 1% 1/4W	144504
R47	METAL FILM RES:2.67K 1% 1/4W	144121	R104	RES MF 22.1OHM 1% 1/4W	144554
R48	METAL FILM RES:2.67K 1% 1/4W	144121	R105	RES MF 10K 1% 1/4W	144504
R50	RES MF 10K 1% 1/4W	144504	R103	RES MF 475 1% 1/4W	144509
R51	RES MF 47.5OHM 1% 1/4W	144642	R63	RES MF 3.32K 1% 1/4W	144518
R52	RES MF 22.1K 1% 1/4W	144564	T9	TRANSFORMER:QUAD DET PRIM	162102
R53	RES MF 4.75K 1% 1/4W	144520	T8	TRANSFORMER:QUAD DET SEC	162103
R54	RES MF 221 1% 1/4W	144559	T7	TRANSFORMER(MATCHING)	162113
R55	RES MF 22.1K 1% 1/4W	144564	T10	10.7MHZ MIXER TRANSFORMER	162114
R56	RES MF 100K 1% 1/4W	144528	T11	AM OSC. COIL	162115
R58	RES MF 22.1K 1% 1/4W	144564	T12	AM RF TRANSFORMER	162117
R60	RES MF 100 OHM 1% 1/4W	144568	T101	AM OSC. COIL	162115
R61	RES MF 100K 1% 1/4W	144528	Y1	CRYSTAL 7.2MHZ	180036
R64	RES MF 10K 1% 1/4W	144504	Y2	CERAMIC RESONATOR 450KHZ	180046

MX119 EXPLODED VIEW

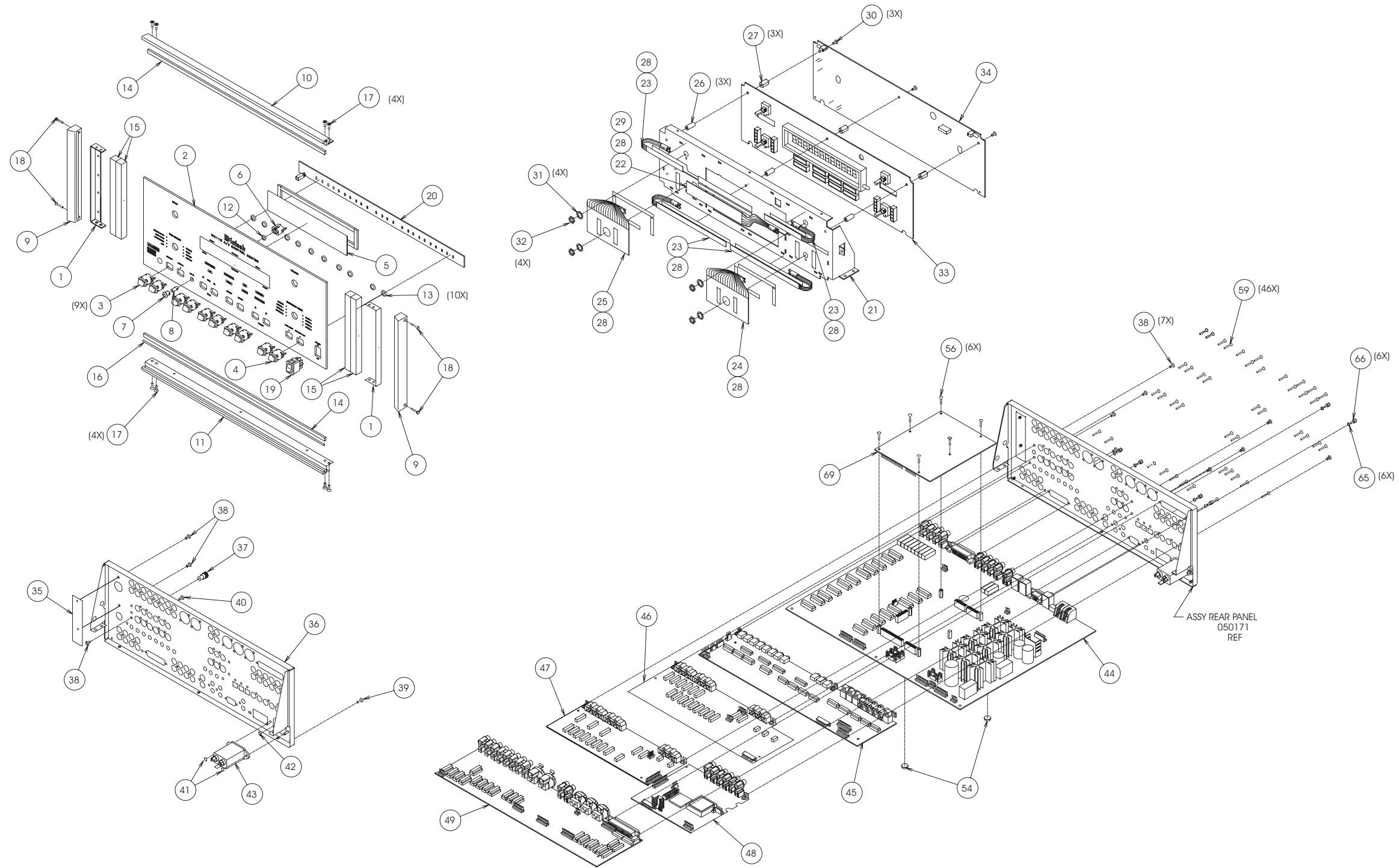

MX119 EXPLODED VIEW and PARTS LIST

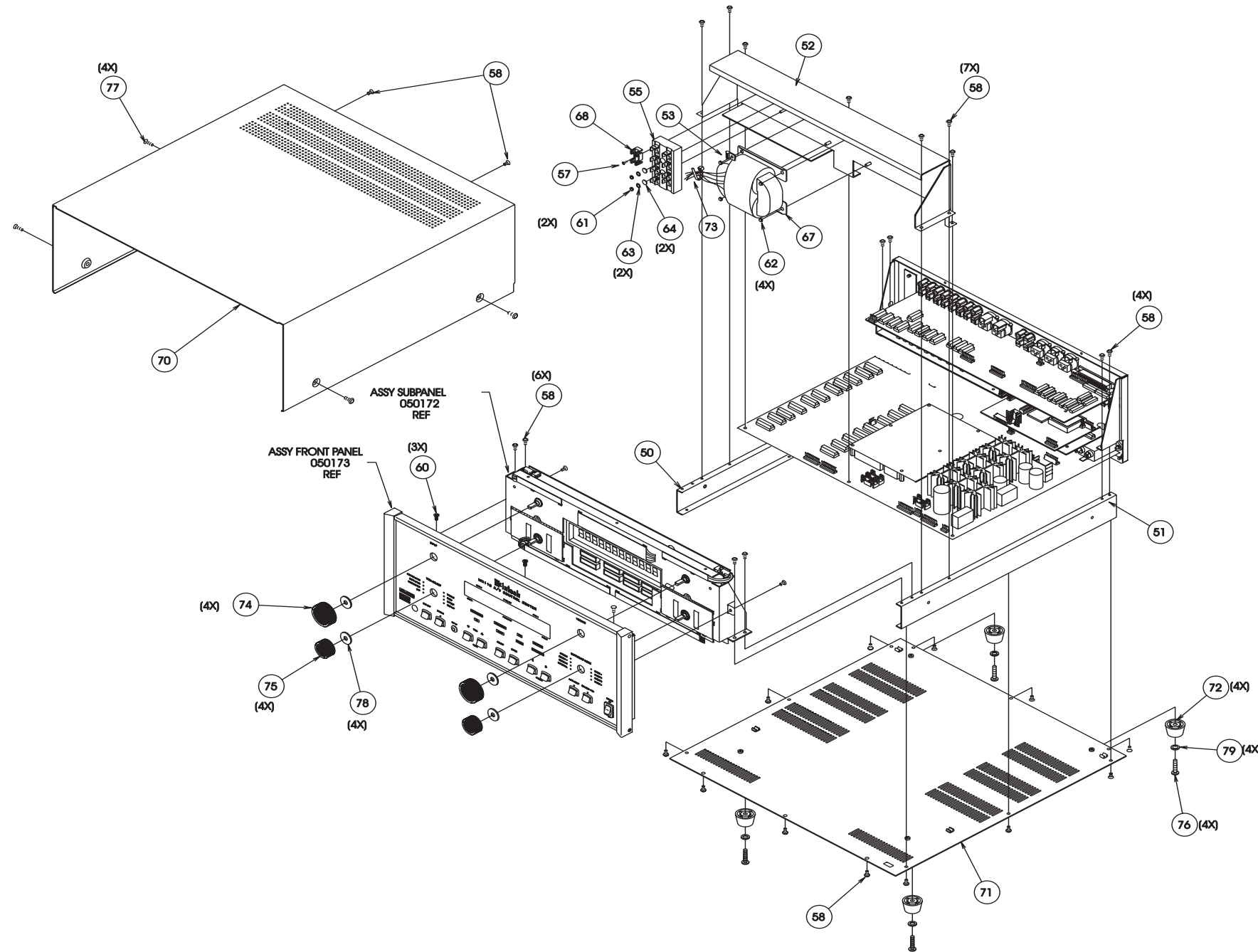

Ref No.	Description	Part No.
1	BRACKET EXTRUSION	004899
2	FAB GLASS PANEL	016524
3	PUSHBUTTON ASSY	017517
4	PUSHBUTTON ASSY RED	017531
5	PLEXI FILTER	017738
6	RECEPTACLE PUSHBUTTON	017741
7	PUSHBUTTON BLACK	017852
8	PUSHBUTTON BEZEL	017938
9	ENDCAP 7 INCH	018612
10	EXTRUSION TOP	018705
11	EXTRUSION BOTTOM	018707
12	O-RING	078032
13	O-RING	078033
14	TAPE FOAM 1/4 X 1/8 IN	094016
15	TAPE FOAM 1/2 X 1/2 IN	094360
16	CORD DIAL .027 BLACK BRAID SLK	098113
17	SCREW MACH 6-32X1/4 FL U/H ST	100149
18	SCREW TS 4-40X1/2 SLOT FLLSTR	101042
19	SWITCH DPDT ROCKER	148073
20	ASSY KEYBOARD PCB	050053
21	FAB SUBPANEL	005455
22	LOGO PUSHBUTTON BACKLIGHT	017901
23	TITLE/PUSHBUTTON BACKLIGHT	017907
24	FAB SELECTOR BACKLIGHT MX135	017975
25	FAB SELECTOR BACKLIGHT MX119	017978
26	SPACER: 6X5/16	021092
27	HEX STANDOFF 6-32 X 1/2	021127
28	FOAM TAPE WHITE 1/32" THK	094429
29	TAPE FOAM WHT 3/8W X 1/32 THK	094431
30	SCREW MACH 6-32 X 1/4 PHIL PAN	100157
31	WASHER INT STAR 3/8X.507X.002	104014
32	NUT CONTROL M9X0.75 PLATED	110002
33	ASSY LED PCB	050169
34	ASSY DISPLAY PCB	050167
35	FAB REAR PANEL PLUG	005078
36	FAB REAR PANEL	005454
37	POST GROUND GOLD	084112
38	SCREW MACH SEMS 6-32X1/4 PH PN	100250
39	SCREW TAP 6-32X5/16 PHL PN BLK	101109
40	SCREW TT SEMS 6-32X1/4 PH PAN	101222
41	NUT KEP 4-40 ZINC PLATE	102001
42	NUT MACH 6-32 SELF-LOCK	102020
43	RECEPTACLE INPUT & LINE FILTER	117755
44	ASSY SURROUND PCB	050168
45	ASSY DATA PCB	050164
46	ASSY S-VIDEO PCB	050166
47	ASSY VIDEO PCB	050165
48	ASSY COMPONENT PCB	050180
49	ASSY INPUT PCB	050163
50	FAB PANEL SIDE LEFT	004858
51	FAB PANEL SIDE RIGHT	004859
52	FAB TRAY	005456
53	TAB MOUNTING .140 DIA MTG	017160
54	BUMPER BUTTON	017191
55	TERMINAL BLOCK AC	074091
56	SCREW MACH 4-40 X 1/4 PHIL PAN	100260
57	SCREW SEMS 2-56X3/16 PHIL PAN	100354
58	SCREW TAPTT 6-32X1/4 PH PN BLK	101054
59	SCREW HI/LO 4-24X3/8 PH RD BLK	101197
60	SCREW 6-32 X 1/4 PHIL FLAT	101232
61	NUT MACH 4-40 3/16X1/16	102022
62	NUT KEP 6-32 SPECIAL	102045
63	WASHER FLAT STEEL 4X9/32X.025	104001
64	WASHER LOCK 5X.255 INT STAR	104004
65	WASHER LOCK 2.5MM INT STR ZINC	104142
66	STANDOFF	112015
67	TRANSFORMER R-CORE POWER	159340
68	HOLDER FUSE 5X20 CHASSIS MOUNT	178160
69	DSP MODULE DAE-5	320173
70	FAB COVER TOP	004863
71	FAB COVER BOTTOM	005176
72	FOOT PLASTIC BLACK	017218
73	CABLE TIE HT5.9	017329
74	ASSEMBLY KNOB 34 MTRC W/O IDX	049637
75	ASSEMBLY KNOB 25.5 NO IDX MTRC	049724
76	SCREW MACH 10-32X3/4 PH PN BLK	100159
77	SCREW TAP 8-32X5/16 PH PN BLK	101078
78	WASHER FELT BLK 3/4X1/4X1/16	104017
79	WASHER FLAT #10 CLEAR ZINC	104080

REPACKING INSTRUCTION

In the event it is necessary to repack the unit for shipment, the unit must be packed exactly as shown below.

IMPORTANT - The four plastic feet must be attached to the bottom of the unit so they will locate in the four holes of the bottom pad. Failure to do this will result in shipping damage.

If a shipping carton or any of the interior parts is needed, please call or write the Customer Service Department of McIntosh Laboratory. Order parts from the accompanying list by part number.

Use the original shipping carton and interior parts only if they are in good serviceable condition.

Qty.	Part No.	Description
1	033888	Shipping carton only
4	033887	Foam end cap
1	033697	Inside carton only
1	033725	Top pad
1	034008/ 034194	Bottom pad
1	034037	Inner carton pad
4	017218	Plastic foot
4	100159	#10-32 x 3/4" Machine screw
4	104083	#10 x 7/16" Flat washer

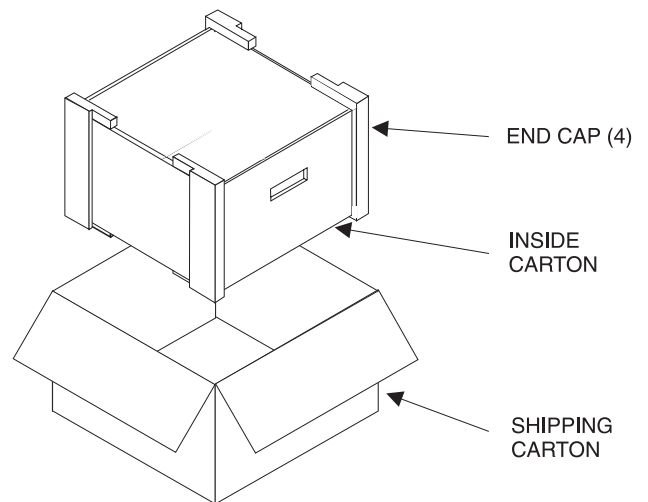
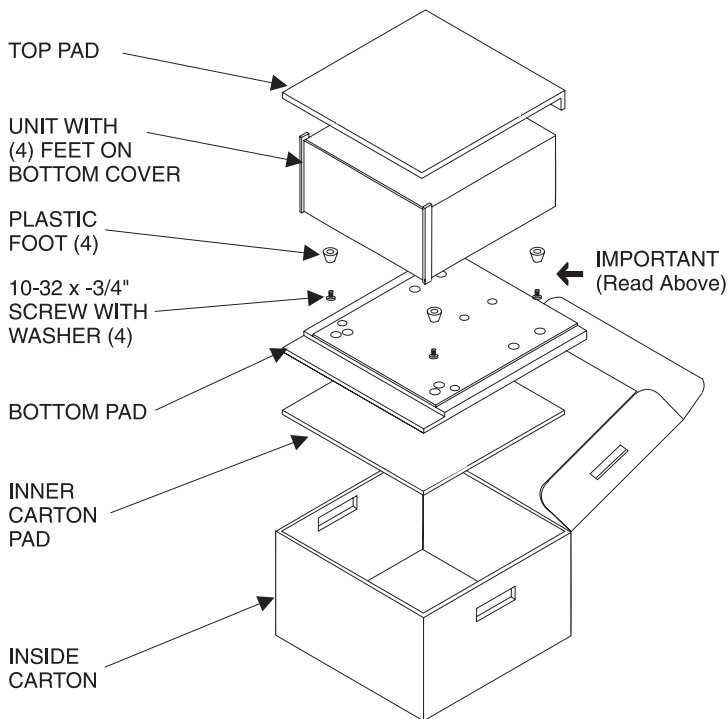

MX119

A/V CONTROL CENTER

SERVICE MANUAL

SERIAL NO. VS1001 And Above



The continuous improvement of its products is the policy of McIntosh Laboratory Incorporated, who reserve the right to improve design without notice. Because of the constant upgrading of McIntosh products' circuitry and components, the Company cannot insure, and does not warrant, the accuracy of the within schematic material, which is intended for information only.